

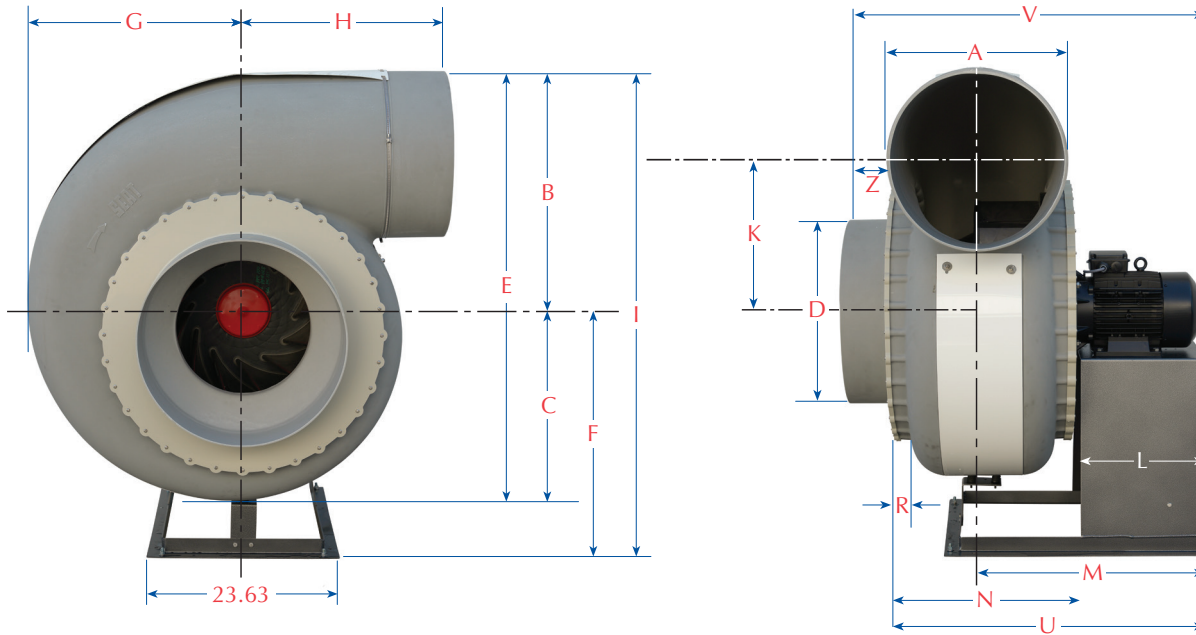

PHONE: (941) 751-7596
 FAX: (941) 751-7598
 www.plastecvent.net

PLASTEC® 50

Impeller Diameter: 30.5



DIMENSIONAL DATA (inches)

A	B	C	D	E	F	G	H	I	I (CCW90)	K+F	K	L	M
20.00	29.53	22.38	23.50	48.07	29.72	26.90	23.50	52.75	59.25	49.25	19.53	15.75	28.15
N	R	U	V	Z									
23.60	2.38	39.50	45.10	5.60									

*Metal Stand Included

ROTATION AND DISCHARGE FOR CENTRIFUGAL FANS



Counter-Clockwise
Up Blast
CCW 360



Counter-Clockwise
Top Horizontal
CCW 90

Notes:

- (1) Direction of rotation is determined from the drive side of fan. **Standard position is up-blast CCW 360.**
- (2) On single inlet fans, drive side is always considered as the side opposite fan inlet.

PLASTEC® 50

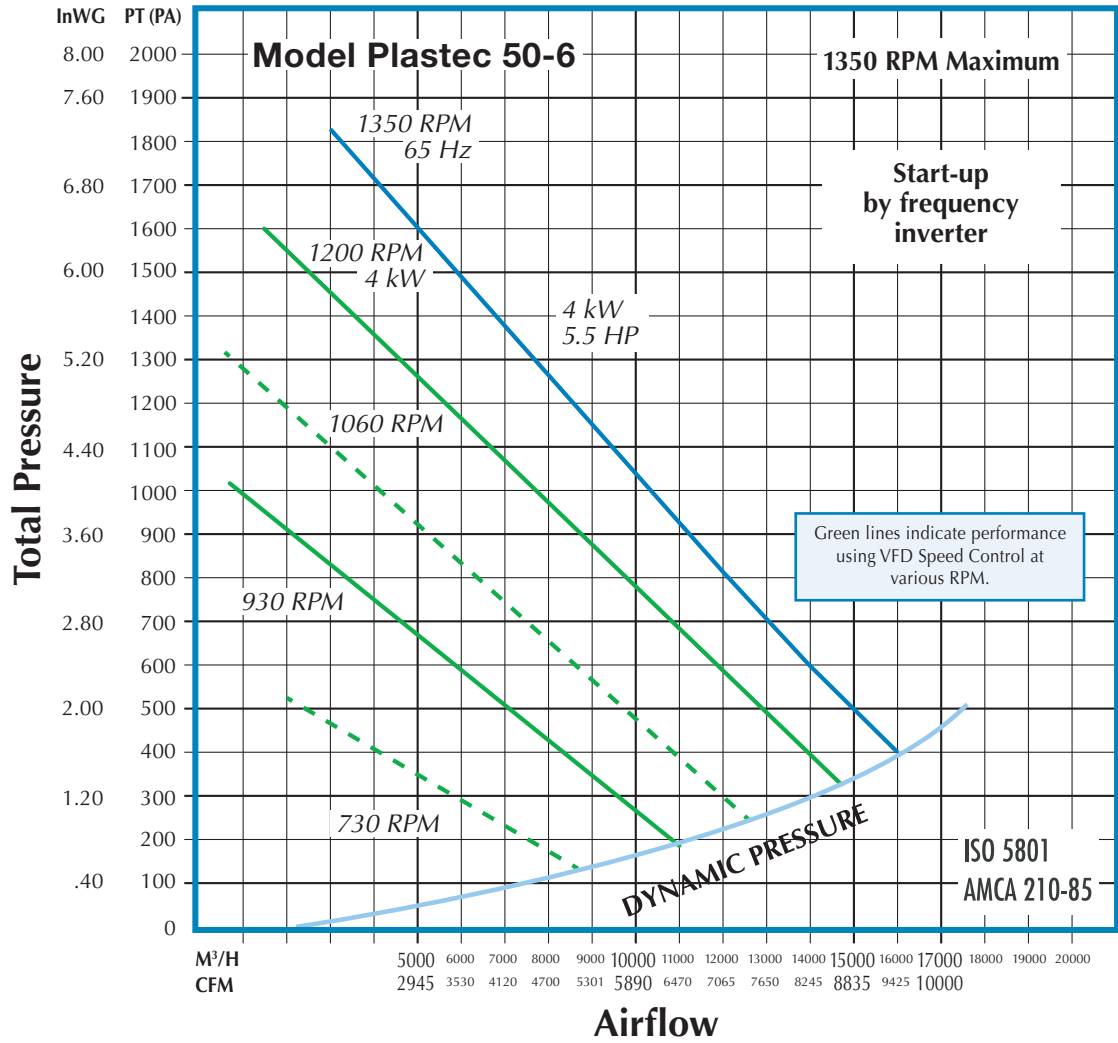

	qv (m ³ .h ⁻¹)	AP stat (Pa)	63 Hz	125 Hz	250 Hz	500 Hz	1000 Hz	2000 Hz	4000 Hz	8000 Hz
Inlet + break out noise (dB)	7429	873	88,9	84,0	87,8	78,2	75,9	74,3	74,8	72,0
	9321	675	88,9	84,4	87,9	79,5	77,3	75,4	75,8	73,8
	11724	366	90,0	85,8	88,9	81,3	79,7	77,7	76,8	73,6
Break out noise (dB)	7429	873	82,9	73,6	73,7	69,0	68,6	60,6	60,1	55,2
	9321	675	85,5	76,7	74,9	70,3	70,3	61,7	60,9	56,2
	11724	366	86,6	79,6	78,7	72,5	72,3	64,2	62,3	56,7
Discharge noise (dB)	7429	873	85,5	91,3	86,3	81,0	78,7	73,6	73,0	72,3
	9321	675	85,8	91,1	87,3	82,7	80,7	75,2	73,6	72,3
	11724	366	86,1	91,9	89,2	85,7	84,1	78,5	75,0	72,3