

SUBMITTAL DATA

horizontal steam/hot water unit heaters top and bottom connection, Model HSB

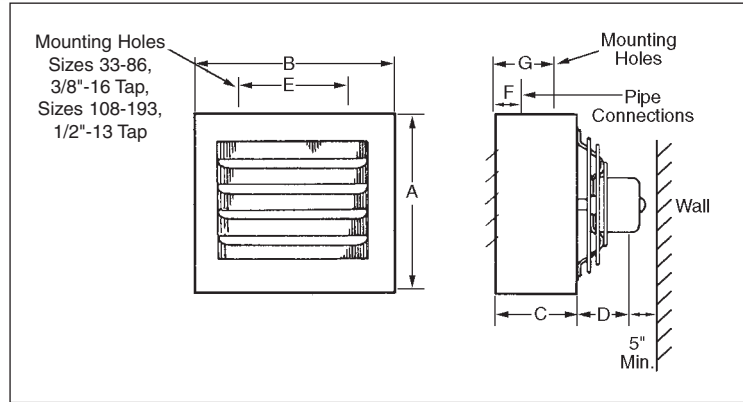

Table 1.1 - Dimensions ①②

Model Number	A	B	C	D		E	F	G	H	Female Connections NPT	Fan Diameter	Approx. Shipping Wt. lb.
				115 Std. Motor	115V Exp. Motor							
HSB-18	12-3/8	13	6	5	12	-	3	-	-	3/4	9	16
HSB-24	12-3/8	13	6	6-1/2	12	-	3	-	-	3/4	9	20
HSB-33	16-3/8	17-1/2	8-3/4	6-1/2	12-1/4	11	3-5/8	6	-	1-1/4	12	34
HSB-47	16-3/8	17-1/2	8-3/4	8	12-1/4	11	3-5/8	6	-	1-1/4	12	36
HSB-63	20-7/16	21-1/2	8-3/4	8	12-3/4	15	3-5/8	6	-	1-1/4	14	48
HSB-86	20-7/16	21-1/2	8-3/4	9	12-3/4	15	3-5/8	6	-	1-1/4	14	52
HSB-108	24-7/16	25-1/2	9-1/2	8	11-1/2	18	3-3/4	6-3/8	-	1-1/4	18	74
HSB-121	24-7/16	25-1/2	9-1/2	7-1/2	11	18	3-3/4	6-3/8	-	1-1/4	18	76
HSB-165	30-1/2	30-1/2	9-1/4	9-1/2	14	21-1/4	3-3/4	6-3/8	-	1-1/4	22	92
HSB-193	30-1/2	30-1/2	9-1/4	9-1/2	14	21-1/4	3-3/4	6-3/8	-	1-1/4	22	98
HSB-258	38-1/2	38-1/2	12-1/2	10-1/2	14	18-1/2	3-5/8	7-7/8	-	1-1/4	22	162
HSB-290	38-1/2	38-1/2	12-1/2	10-1/2	14	18-1/2	3-5/8	7-7/8	-	1-1/4	24	168
HSB-340	38-1/2	44-1/2	12-1/2	10-1/2	14	18-1/2	3-5/8	7-7/8	-	1-1/4	24	176

① All dimensions in inches.

② Dimensions shown are for Standard and Low Outlet Temperature models.

Table 1.2 - Specifications

Model No.	Core Type		Copper Tube Size (Inches)	Copper Tube Wall Thickness (Inches)
	Single Serpentine	Double Serpentine		
HSB-18	X	-	5/8 OD	0.028
HSB-24	X	-	5/8 OD	0.028
HSB-33	X	-	1 OD	0.030
HSB-47	X	-	1 OD	0.030
HSB-63	X	-	1 OD	0.030
HSB-86	X	-	1 OD	0.030
HSB-108	X	-	1 OD	0.030
HSB-121	X	-	1 OD	0.030
HSB-165	X	-	1 OD	0.030
HSB-193	-	X	1 OD	0.030
HSB-258	-	X	1 OD	0.030
HSB-290	-	X	1 OD	0.030
HSB-340	-	X	1 OD	0.030

Junction Box

All units include an electrical junction box either integral to the motor or attached to the unit casing. Explosion proof units include an explosion proof junction box attached to the motor.

1-451.13 SUBMITTAL DATA

Table 2.1
Motor Data ①

Model Number	Motor HP ②	Motor Type, Voltage and Power Code							
		Totally Enclosed w/Thermal Overload						Explosion Proof w/Thermal Overload	
		115/60/1	200/60/1	230/60/1	200-208/60/3	230/460/3	575/60/3	115/60/1	230/460/60/3
		01	N/A	02	04	05	10	06	09
		Amps	Amps	Amps	Amps	Amps	Amps	Amps	Amps
HSB/HC-18	1/60	0.8	③	0.44	③	③	③	3.1	-
HSB/HC-24	1/25	1.6	③	0.44	③	③	③	3.1	-
HSB/HC-33	1/25	1.6	③	1	③	③	③	3.1	-
HSB/HC-47	1/12	2.2	③	1	③	③	③	3.1	-
HSB/HC-63	1/12	2.2	③	1	③	③	③	3.1	-
HSB/HC-86	1/8	2.3	③	1	③	③	③	3.1	-
HSB/HC-108	1/8	2.3	③	1	③	③	③	3.1	-
HSB/HC-121	1/5	2.8	③	1.5	③	③	③	4.1	1.5/0.75
HSB/HC-165	1/3	5.4	③	2.23	③	③	③	6.1	1.5/0.75
HSB/HC-193	1/3	5.4	③	2.23	③	③	③	6.1	1.5/0.75
HSB/HC-258	1/2	7.5	③	3.5	③	③	③	5.8	2.0/1.0
HSB/HC-290	1/2	7.5	③	3.5	③	③	③	5.8	2.0/1.0
HSB/HC-340	1/2	7.5	③	3.5	③	③	③	5.8	2.0/1.0

- ① Ratings shown are for Standard and Low Outlet Temperature Models.
- ② Motor HP listed for power code 01.
- ③ For supply voltages of 200V/60Hz/1ph and all non-explosion proof 3 phase voltages of 200, 230, 460 and 575, Model Numbers indicated with Note ③, require that a 115V/60Hz/1 phase Power Code 01 unit heater be used with a shipped loose accessory transformer. See Table 2.2 for Transformer Sizes.

Figure 2.1
Field Installed Transformer Accessory



Table 2.2 - Step-Down Transformer Accessory Selection

	200V/60Hz/1 or 3 phase	230/460V/ 60Hz/3 phase	575V/60Hz/ 3 phase
Model Number	kVA	kVA	kVA
HSB 18-63	0.50	0.25	0.25
HSB 86-121		0.50	0.50
HSB165-193	1.00	0.75	0.75
HSB258-340		1.00	1.00

kVA Size	Ship Wt. (Lb.)
0.25	7
0.50	13
0.75	15
1.00	19