

INSTALLATION AND SERVICE MANUAL steam/hot water unit heaters



Model HSB
Horizontal Delivery
Top/Bottom
Inlet/Outlet



Model HC
Horizontal Delivery
Side
Inlet/Outlet



Models V/VN
Vertical Delivery



Model PT/PTN
"Power-throw"



General Information

Installation and service instructions in this manual are applicable to the three types of steam/hot water unit heaters which should be installed in their proper applications for their most effective function as overhead heating units.

The copper coils are warranted for operation at steam or hot water pressures up to 150 lbs. per sq. in. gauge, and or temperatures up to 375°F, cupronickel tube units are warranted for operating pressures up to 250 PSI and operating temperatures up to 400°F. Canadian Standards Association (CSA) requirements state that explosion-proof units may not be used with a fluid temperature in excess of 329°F and still maintain their explosion-proof rating, for national electric code ignition temperature rating T3B for grain dust.

Motors are designed for continuous duty. They can operate in a maximum ambient temperature of 104°F (40°C).

The unit heaters are listed by the Canadian Standards Association as certified and Canadian Registered heat exchangers CRN OH 9234.5.

IMPORTANT

The use of this manual is specifically intended for a qualified installation and service agency. A qualified installation and service agency must perform all installation and service of these appliances.

Inspection On Arrival

1. Inspect unit upon arrival. In case of damage, report it immediately to transportation company and your local factory sales representative.
2. Check rating plate on unit to verify that power supply meets available electric power at point of installation.
3. Inspect unit received for conformance with description of product ordered (including specifications where applicable).

CAUTION

Do not remove outlet fan guard from vertical type unit heaters.

Steam horizontal and vertical delivery unit heaters are available in both standard and low-outlet temperature models. Low outlet temperature models are recommended primarily for installation on heating systems with steam pressures of 30 to 150 PSI. When used at these steam pressures they provide lower outlet air temperatures for longer heat throw and, because of wider fin spacing, they are less susceptible to clogging in dusty atmospheres.

The model number of each unit heater indicates its rated Btu/Hr. capacity/1000 at 2 lbs. steam pressure and 60°F entering air temperature. For example an HSB-63 has an output of 63,000 Btu/Hr. at 2 lbs. steam and 60°F entering air.

SPECIAL PRECAUTIONS / TABLE OF CONTENTS / SI (METRIC) CONVERSION FACTORS

SPECIAL PRECAUTIONS

THE INSTALLATION AND MAINTENANCE INSTRUCTIONS IN THIS MANUAL MUST BE FOLLOWED TO PROVIDE SAFE, EFFICIENT AND TROUBLE-FREE OPERATION. IN ADDITION, PARTICULAR CARE MUST BE EXERCISED REGARDING THE SPECIAL PRECAUTIONS LISTED BELOW. FAILURE TO PROPERLY ADDRESS THESE CRITICAL AREAS COULD RESULT IN PROPERTY DAMAGE OR LOSS, PERSONAL INJURY, OR DEATH. THESE INSTRUCTIONS ARE SUBJECT TO ANY MORE RESTRICTIVE LOCAL OR NATIONAL CODES.

HAZARD INTENSITY LEVELS

- DANGER:** Indicates an imminently hazardous situation which, if not avoided, WILL result in death or serious injury.
- WARNING:** Indicates a potentially hazardous situation which, if not avoided, COULD result in death or serious injury.
- CAUTION:** Indicates a potentially hazardous situation which, if not avoided, MAY result in minor or moderate injury.
- IMPORTANT:** Indicates a situation which, if not avoided, MAY result in a potential safety concern.



DANGER

Appliances with power codes 01, 02, 04, 05, and 10 must not be installed where they may be exposed to a potentially explosive or flammable atmosphere.



WARNING

- Disconnect power supply before making wiring connections to prevent electrical shock and equipment damage.
- All appliances must be wired strictly in accordance with wiring diagram furnished with the appliance. Any wiring different from the wiring diagram could result in a hazard to persons and property.
- Any original factory wiring that requires replacement must be replaced with wiring material having a temperature rating of at least 105°C.
- Ensure that the supply voltage to the appliance as indicated on the serial plate, is not 5% greater than the rated voltage.
- When servicing or repairing this equipment, use only factory-approved service replacement parts. A complete replacement parts list may be obtained by contacting Modine Manufacturing Company. Refer to the rating plate on the appliance for complete appliance model number, serial number, and company address. Any substitution of parts or controls not approved by the factory will be at the owner's risk.



CAUTION

- Do not remove outlet fan guard from vertical type unit heaters.
- Do not install units below 8 feet measured from the bottom of the unit to the floor.
- Servicing or repairing of this equipment must be performed by a qualified service agency.
- Do not reuse any electrical component which has been wet. Replace component.
- Ensure that the supply voltage to the appliance, as indicated on the serial plate is not 5% less than the rated voltage.

IMPORTANT

- Start-up and adjustment procedures should be performed by a qualified service agency.
- To check most of the Possible Remedies in the troubleshooting guide listed in Table 15.1, refer to the applicable sections of the manual.

Table of Contents

General Information.....	1
Special Precautions.....	2
SI (Metric) Conversion Factors.....	2
Unit Location.....	3
Unit Mounting	3-4
Unit Suspension	5
Installation	5-6
Piping.....	5
Electrical Connections	5
Operation.....	6
Prior to Operation.....	6
Initial Start-up.....	6
Automatic Control Operations	6
General	7
Performance Data	8-11
Dimensional Data	12-13
Motor Ampere Ratings.....	14
Service.....	14
Service / Troubleshooting	15
Warranty	Back Page

SI (METRIC) CONVERSION FACTORS

Table 2.1

To Convert	Multiply By	To Obtain	To Convert	Multiply By	To Obtain
"W.C.	0.249	kPa	feet	0.305	m
°F	(°F-32) x 5/9	°C	Gal/Hr.	0.00379	m ³ /hr
Btu	1.06	kJ	Gal/Hr.	3.79	l/hr
Btu/ft ²	37.3	kJ/m ²	gallons	3.79	l
Btu/hr	0.000293	kW	Horsepower	746	W
CFH (ft ³ /hr)	0.000472	m ³ /min	inches	25.4	mm
CFH (ft ³ /hr)	0.00000787	m ³ /s	pound	0.454	kg
CFM (ft ³ /min)	0.0283	m ³ /min	psig	6.89	kPa
CFM (ft ³ /min)	0.000472	m ³ /s	psig	27.7	"W.C.

UNIT LOCATION / UNIT MOUNTING

UNIT LOCATION

! DANGER

Appliances with power codes 01, 02, 04, 05, and 10 must not be installed where they may be exposed to a potentially explosive or flammable atmosphere.

1. Units should not be installed in atmospheres where corrosive fumes or sprays are present.
2. Be sure no obstructions block air intake or air discharge of unit heater.
3. Locate horizontal delivery unit heaters so air streams of individual units wipe the exposed walls of the building with either parallel or angular flow without blowing directly against the walls. Heaters should be spaced so the air stream from one supports the air stream from another heater. See Figure 3.1.
4. Columns, machinery, partitions, and other obstacles should not interfere with air streams from unit heaters.
5. Unit heaters installed in a building exposed to a prevailing wind should be located to direct a major volume of heated air along the windward wall of the building.
6. Large expanses of glass, or large doors that are frequently opened, should be covered by long-throw unit heaters such as large horizontal delivery of "Power-Throw" unit heaters.
7. Vertical delivery unit heaters should generally be located in the central area of the space to be heated. Place horizontal delivery units along the walls of the same building where heat loss is usually greatest. See Figure 3.3.
8. Arrange horizontal delivery units so they do not blow directly at occupants. Air streams from this type of unit should be directed down aisles, into open spaces on the floor, or along exterior walls.
9. When only vertical delivery units are installed, they should be located so exposed walls are blanketed by their air streams. See Figure 3.2.

Figure 3.1 - Horizontal Delivery Unit Location

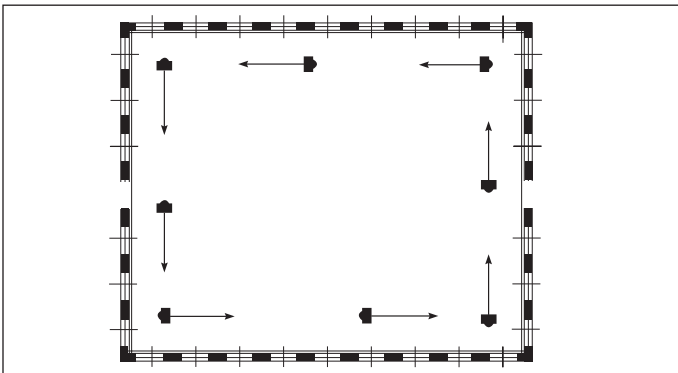

**Figure 3.2
Unit Locations of Vertical Units In Narrow Buildings**

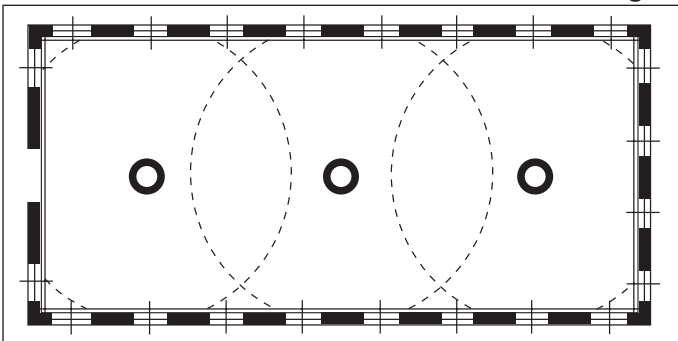

**Figure 3.3
Combination Horizontal and Vertical Delivery Unit Installation**

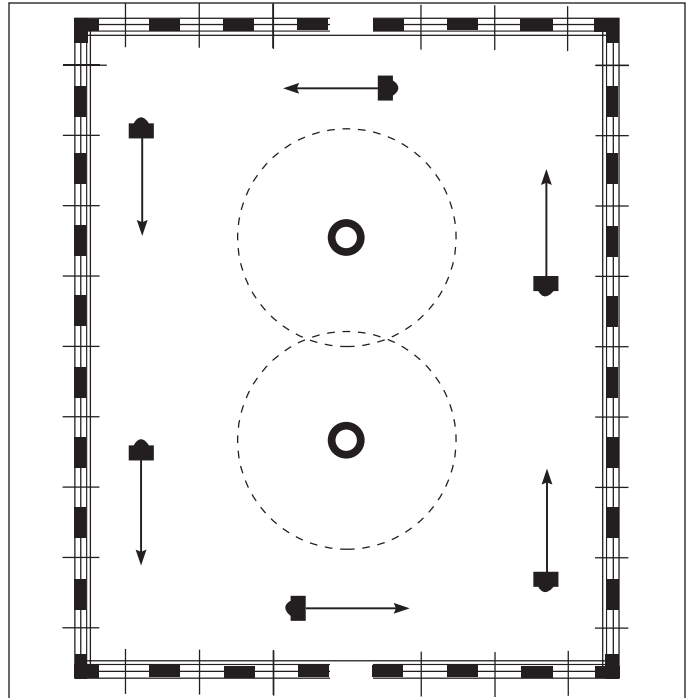

UNIT MOUNTING

! CAUTION

Do not install units below 8 feet measured from the bottom of the unit to the floor.

Do not install unit above recommended maximum mounting heights. Height at which unit heaters are installed is critical. Maximum mounting heights for all units are listed in Table 4.1 and the height dimensions are shown in Figures 4.3 through 4.7. Maximum mounting heights for vertical models are given for units with or without optional air deflectors. The data in Table 4.1 is based on operating conditions of 2 lbs. steam or 220°F entering water with 60°F entering air. When operating conditions are other than those above, refer to Figure 4.2 for maximum mounting height correction factor. To obtain the maximum mounting at actual operating conditions, multiply the appropriate factor from Figure 4.2 by the mounting height in Table 4.1. The maximum mounting height for all units is that height above which the unit heater will not deliver heated air to the floor at standard rating conditions.

Deflector Mounting

If an optional air deflector has been furnished for vertical units, it is always shipped separately and can be attached to the unit before suspension. Vertical louvers for horizontal units and horizontal louvers for "Power-Throw" units can also be added and positioned before installation. Cone-jet and louver-type deflectors must be attached with angle brackets and machine screws to the bottom cover of the unit. Refer to mounting instructions which are furnished with each deflector.

Depending on supply or return piping arrangement, there is a possibility of interference between certain anemostat air deflectors and piping on some vertical air delivery unit heaters. Check dimensions.

UNIT MOUNTING

Table 4.1 - Maximum Mounting Heights

Horizontal Type ①			"Power-Throw" Type ②			Vertical Type with Deflectors ②								
Model No.	Height-Ft.		Model No.	Height-Ft.		No Deflector			Cone-Jet		Truncone		Louvers	
	Std.	L.O.T.		Std.	L.O.T.	Model No.	Height-Ft.		Height-Ft.		Height-Ft.		Height-Ft.	
							Std.	L.O.T.	Std.	L.O.T.	Std.	L.O.T.	Std.	L.O.T.
HSB/HC-18	8	9	—	—	—	V/VN-42 ②	11	13	15	17	8	9	13	15
HSB/HC-24	9	11	—	—	—	V/VN-59 ②	14	16	19	22	9	11	16	18
HSB/HC-33	10	12	—	—	—	V/VN-78 ②	15	19	20	26	11	14	17	22
HSB/HC-47	12	14	—	—	—	V/VN-95 ②	15	19	20	26	11	14	17	22
HSB/HC-63	14	16	—	—	—	V/VN-139 ②	18	23	24	31	13	17	21	26
HSB/HC-86	15	17	—	—	—	V/VN-161 ②	20	26	27	35	14	18	23	30
HSB/HC-108	17	19	—	—	—	V/VN-193 ②	22	27	30	36	16	19	25	31
HSB/HC-121	16	18	—	—	—	V/VN-212 ②	22	27	30	36	16	19	25	31
HSB/HC-165	19	21	—	—	—	V/VN-247 ②	26	32	34	42	17	21	30	37
HSB/HC-193	18	—	PT/PTN-279 ②	16	—	V/VN-279 ②	30	36	37	45	18	22	35	41
HSB/HC-258	19	22	PT/PTN-333 ②	17	—	V/VN-333 ②	30	36	37	45	17	20	35	41
HSB/HC-290	20	23	PT/PTN-385 ②	17	—	V/VN-385 ②	30	36	36	43	17	20	35	41
HSB/HC-340	20	23	PT/PTN-500 ②	18	—	V/VN-500 ②	37	45	44	54	19	24	42	51
—	—	—	PT/PTN-610 ②	20	22	V/VN-610 ②	36	44	43	52	19	24	41	50
—	—	—	PT-952	21	—	V-952 ②	37	45	45	61	45	53	—	—

① With horizontal louvers opened 30° from the vertical plane. HSB units have top and bottom piping connections, HC units have side connections. All have copper tubes.
 ② V and PT models have copper tubes, VN and PTN models have cupronickel tubes. Mounting heights are maximum for heaters operating at standard conditions (2 lbs. steam or 220°F water with 60°F entering air). Heights listed for Louver or Cone-Jet are with deflectors in fully-opened position. Refer to Figure 4.2 for correction of mounting heights under other operating conditions. Maximum mounting height will be reduced as entering air temperatures exceed 60°F.

Figure 4.2 - Maximum Mounting Heights Correction Factors

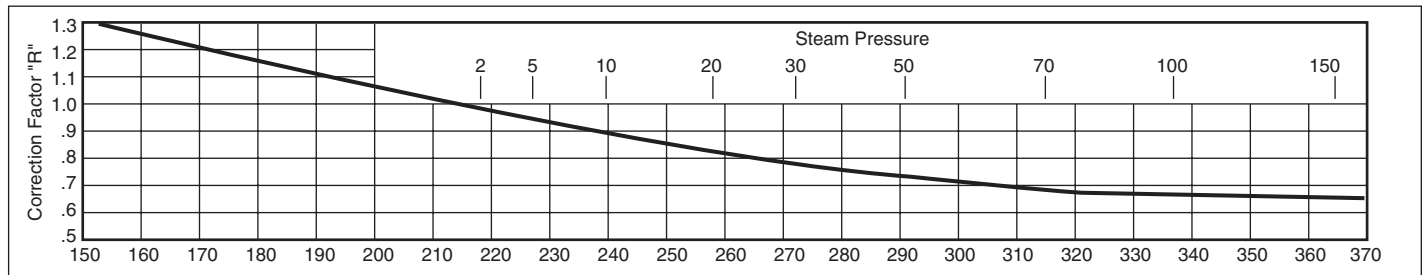

These correction factors are to be used as multipliers to correct the maximum recommended mounting heights of unit heaters when operated with steam pressures other than 2 pounds or with water at other than average temperature of 220°F.

Figure 4.3 - Horizontal Unit Delivery

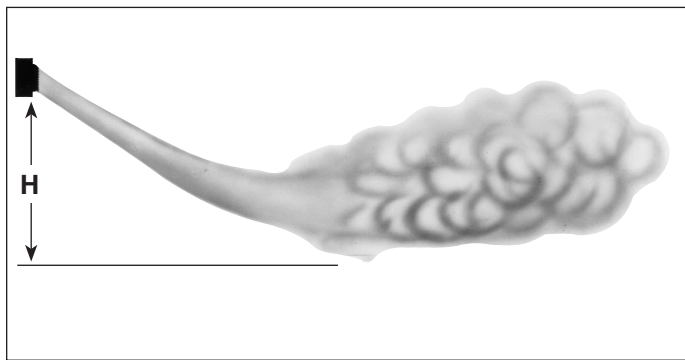

Figure 4.4 - Vertical One-Way & Two-Way Louvers

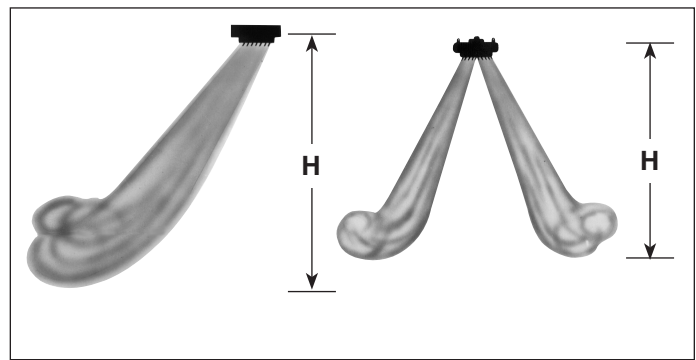

Figure 4.3 Vertical Cone Jet

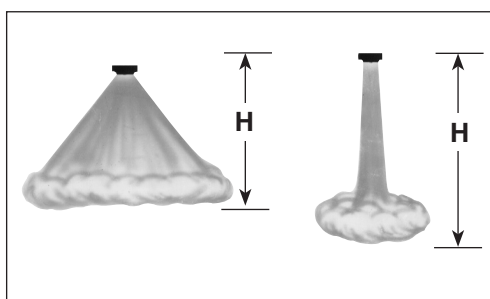
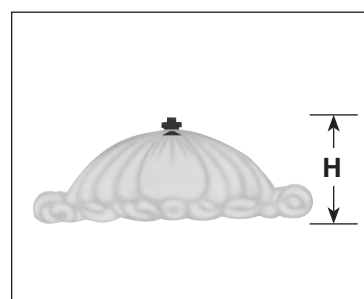

Figure 4.6 - Vertical Truncone



UNIT SUSPENSION / INSTALLATION

UNIT SUSPENSION

Horizontal delivery units, Model HSB/HC Series. All horizontal delivery units, except Models HSB-18 and HSB-24, have two tapped holes in the top for unit suspension. HSB-18 and HSB-24 models do not require independent suspension and are installed directly on their supply piping. Models HSB 33-86 and HC 18-86 have 3/8"-16 tapped holes, model sizes 108 and larger have 1/2"-13 tapped holes. Piping support hangers or clamps are recommended and should be placed as close to the unit heater as possible. For other models, independent suspension can be made with threaded rods, pipes, or ceiling hanger brackets. See Figure 5.1.

Vertical delivery units. Vertical delivery Models V/VN-42 through V/VN-279 have four tapped holes (1/2"-13) in the top cover for unit suspension. Unit suspension for these models can be made with threaded rods, pipes or ceiling hanger brackets. Models V/VN-333 through V/VN-952 are equipped with an angle-iron mounting bracket that has eight 5/8-inch diameter hanger holes permitting hook-hoisting and suspension with cables, if desired. A 1/2-inch U-bolt, 3-inch center can be inserted in the two holes at each end of the bracket to accommodate suspension with four threaded rods, pipes or hanger brackets.

Power-Throw horizontal delivery units. "Power-Throw" units are designed for horizontal air delivery and are equipped with hanger brackets for suspension. Three hanger brackets are supplied for Model PT/PTN-279, one on the front, and two on the rear panel for three-point suspension. Only two hanger brackets are furnished on the front panel of Models PT/PTN-333 through PT/PTN-952 (for required four-point suspension use the two hanger brackets on the front panel and the two holes on the ends of the upper angle supports at the rear of the unit). Each hanger bracket has a 5/8-inch diameter mounting hole for hook-hoisting and suspension with threaded rods, pipes, or cables.

Note: A pipe hanger adapter kit as illustrated in Figure 5.1 is available as an accessory from Modine. The kit consists of two drilled 3/4-inch I.P.S. pipe caps and two capscrews to facilitate threaded-pipe suspension. One kit will mount applicable HSB or HC models, two kits are required for V/VN models.

Figure 5.1
Unit Suspension

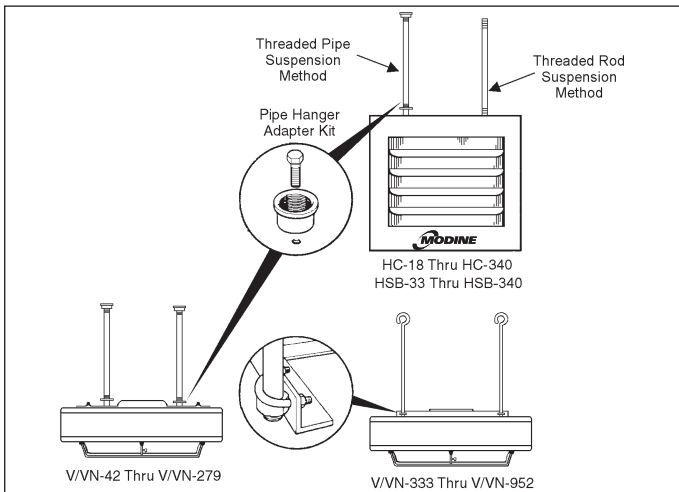

Piping - See Figure 6.1

1. Branch piping to and from unit heater should include swing joints to allow for expansion and contraction of the piping without placing a strain on the unit heater element. On steam systems, the branch piping should be taken off and returned above the centerline of the supply and return lines.
2. Install pipe unions and shut-off valves in lines to and from each unit heater to allow maintenance or replacement of unit without shutting down and draining entire system. For

hot water systems, include a balancing valve in return line for water flow regulation. A drain valve should also be provided below each unit heater to allow removal of water from the heating coil if located in an area subject to freezing.

3. In steam or hot water systems, rapid air removal is required because entrained air is a cause of corrosion. Hot water systems should be equipped with suitable air vent valves for rapid and complete removal of air at the high points and ends of both supply and return mains. Proper air venting for steam systems can be achieved by use of a steam trap with an internal air vent.
4. Traps must be located below the outlet of the unit. Consult trap manufacturer for specific recommendations. Each steam unit heater should be provided with a trap of sufficient size and capacity to pass a minimum of two times the normal condensate released by the unit at the minimum differential pressure in the system. Trap capacity is based on the pressure differential between supply and return mains. Steam systems should be equipped with a float and thermostatic trap or an inverted bucket trap with an air bypass.
5. It is advisable to use a pipe line strainer before each steam trap draining a unit heater. This protection will reduce the maintenance of the steam trap. When strainers are used they should be installed between the unit heater and the trap and be the same size as the trap tapping. In order to catch dirt and scale, the strainer should have a screen perforation size smaller than the trap orifices.
6. On systems where the steam supply to the unit heater is modulated or controlled by a motorized valve, a vacuum breaker should be installed between unit outlet and the trap. If a vacuum breaker is used, it should be in conjunction with a float and thermostatic trap.
7. Install a scale pocket at bottom of unit heater to collect dirt and scale as shown in illustrations. Pipe diameter must be the same size as unit connections and about six inches long.
8. Provide adequate pipe hangers, supports, or anchors to secure the piping system independently of the unit heater.

Electrical Connections

⚠ WARNING

1. Disconnect power supply before making wiring connections to prevent electrical shock and equipment damage.
2. All appliances must be wired strictly in accordance with wiring diagram furnished with the appliance. Any wiring different from the wiring diagram could result in a hazard to persons and property.
3. Any original factory wiring that requires replacement must be replaced with wiring material having a temperature rating of at least 105°C.
4. Ensure that the supply voltage to the appliance as indicated on the serial plate is not 5% greater than the rated voltage.

⚠ CAUTION

1. Do not install units below 8 feet measured from the bottom of the unit to the floor.
2. Do not reuse any electrical component which has been wet. Such component must be replaced.
3. Ensure that the supply voltage to the appliance, as indicated on the serial plate is not 5% less than the rated voltage.
1. Installation of wiring must conform with local building codes, or in the absence of local codes, with the National Electric Code ANSI/NFPA 70 - Latest Edition. Unit must be electrically grounded in conformance to this code. In Canada, wiring must comply with CSA C22.1, Electrical Code.

INSTALLATION / OPERATION

Figure 6.1 - Suggested Piping Arrangements ①

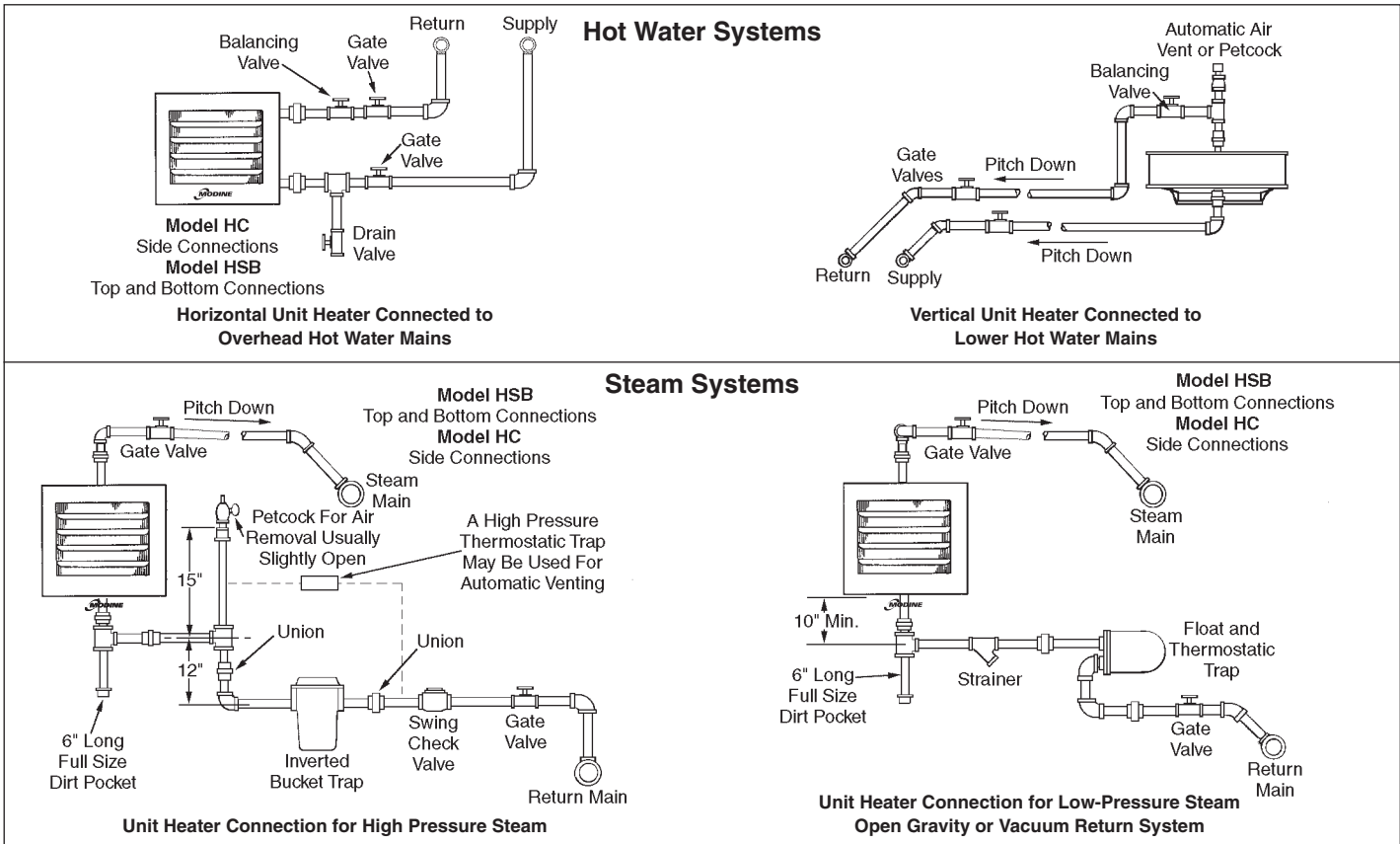

① Arrangements shown are recommendations only. Where horizontal units are shown, vertical units can be substituted or vice versa. For modifications to piping suggestions shown, refer to your local plumbing authority.

Electrical Connections (Cont.)

- Electric wiring must be sized to carry the full load amp draw of the motor, starter, and any controls that are used with the unit heater. All units with power codes 04, 05, 09, or 10 (polyphase motors) must be provided with suitable overcurrent protection in circuit supplying heater at installation. Overcurrent protectors should be sized based on motor current rating shown on the unit serial plate, and applicable national electric code procedures.

All units are provided with an electrical junction box. Junction boxes are either integral to the motor or attached to the unit casing. Units with explosion-proof motors have an explosion-proof junction box attached to the motor.

Any damage to or failure of Modine units caused by incorrect wiring of the units is not covered by Modine's standard warranty.

- Location of room thermostat, when supplied, should be in the natural circulating path of room air. Mount thermostat about five feet above floor level where it will not be affected by heat from the unit or other sources of drafts that would prevent it from properly controlling room temperature. See instructions packed with the thermostat.
- Speed controllers furnished with specified unit heater fan motors, are packed separately and must be connected according to wiring diagram with each controller.

OPERATION

Prior to Operation

- Make sure fuses are installed in fused disconnect switches.
- Check all electrical connections to assure they are secure.
- Check rigidity of unit mounting. Tighten all fasteners, if necessary.
- Inspect piping, strainers, traps, fittings, etc.

Initial Start-Up

- Set thermostat to lowest position.
- Turn on power supply to unit.
- Open return gate valve, and then open supply gate valve to unit.
- Raise thermostat setting to desired position.
- Adjust louvers (if provided) for desired heat distribution.
- To insure proper sequence of operation, cycle unit on and off a few times by raising and lowering thermostat setting.
- Check for proper rotation of fan. All fans must rotate in a counterclockwise direction when viewed from the back (HSB/HC, PT/PTN) or top (V/VN) of the unit heater.

Automatic Control Operations

Install one of the following operating systems for continuous automatic control.

Intermittent Fan Operation — Hot Coil

A room thermostat starts and stops the fan motor. An aquastat is sometimes strapped to the return piping to prevent fan operation when heat is not being supplied to the unit heater.

Continuous Fan Operation — Intermittent Hot/Cold Coil

A room thermostat controls a valve which opens to allow steam or hot water to supply the unit and closes to shut off the supply when the thermostat is satisfied.

OPERATION

Figure 7.1
Horizontal Delivery Unit Cutaway

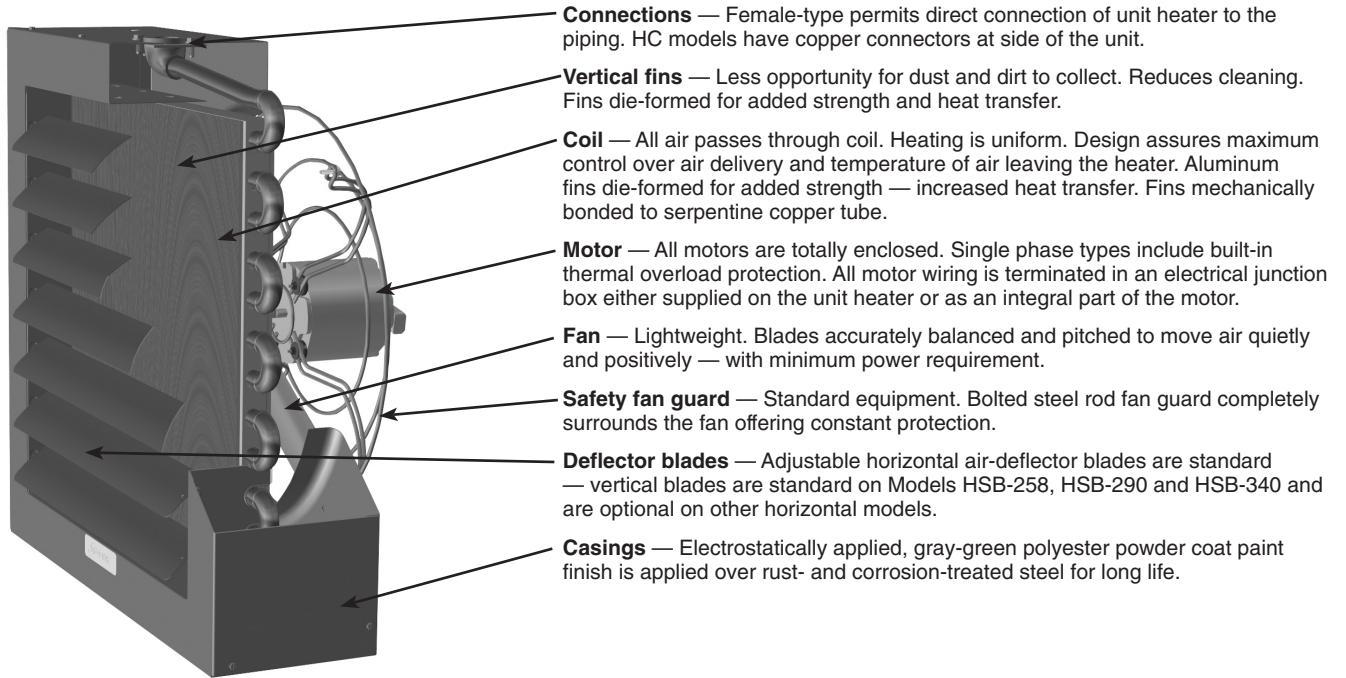

Figure 7.2
Typical Horizontal Unit with Standard Junction Box

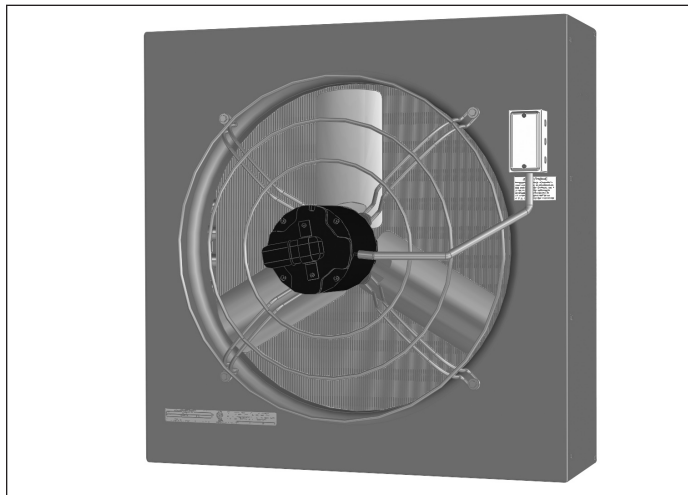

Figure 7.3
Horizontal Unit with Optional Fingerproof Fan Guard

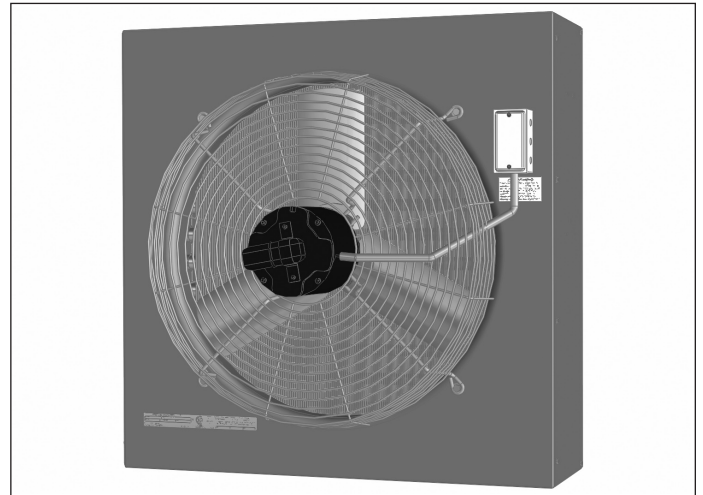
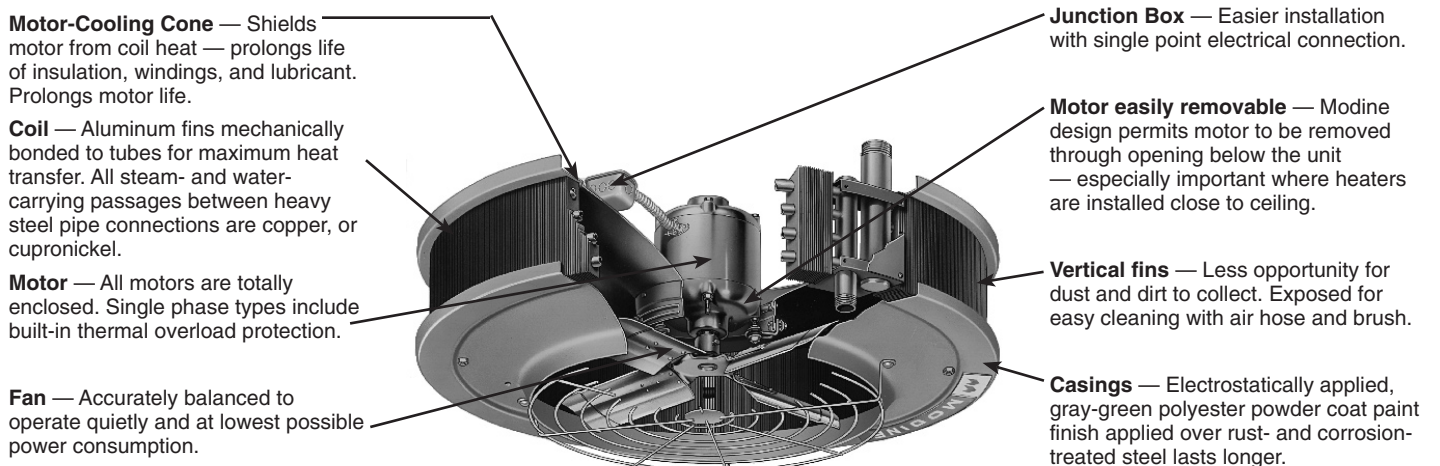

Figure 7.4
Vertical Delivery Unit Cutaway



STEAM PERFORMANCE DATA - STANDARD MODELS

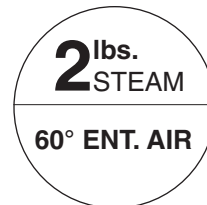

Table 8.1
Performance Data for Standard Units at Standard Conditions of 2 lb. Steam and 60°F Entering Air
High Motor Speed

Type	Model No.	Btu/hr	Sq. Ft. EDR	Air Data							Motor Data			
				Sound Class ④	Maximum Mounting Height (ft.) ①	Heat Throw or Spread @ Max. Height ①	CFM ②	Outlet Velocity (Fpm)	Final Air Temp. (°F)	Condensate lb/hr	Hp	Approx. RPM		
Horizontal Delivery	HSB/HC-18	18,000	75	II	8	17	340	625	107	19	1/60	1550		
	HSB/HC-24	24,000	100	II	9	18	370	695	119	25	1/25	1550		
	HSB/HC-33	33,000	138	II	10	21	630	690	108	34	1/25	1550		
	HSB/HC-47	47,000	196	III	12	28	730	810	119	49	1/12	1550		
	HSB/HC-63	63,000	263	III	14	29	1120	690	111	65	1/12	1550		
	HSB/HC-86	86,000	358	III	15	31	1340	835	118	89	1/8	1625		
	HSB/HC-108	108,000	450	III	17	31	2010	790	109	112	1/8	1625		
	HSB/HC-121	121,000	504	III	16	25	1775	715	122	125	1/5	1075		
	HSB/HC-165	165,000	688	IV	19	40	3240	880	106	171	1/3	1075		
	HSB/HC-193	193,000	804	IV	18	38	2900	810	121	200	1/3	1075		
	HSB/HC-258	258,000	1075	V	19	44	4560	750	111	267	1/2	1075		
HSB/HC-290	290,000	1208	V	20	46	4590	765	117	300	1/2	1075			
HSB/HC-340	340,000	1417	V	20	46	5130	735	120	352	1/2	1075			
Power Throw™ ③	PT/PTN-279	279,000	1163	V	16	100	5460	2165	111	289	1/2	1075		
	PT/PTN-333	333,000	1388	VI	17	110	5980	2165	116	345	3/4	1140		
	PT/PTN-385	385,000	1604	VI	17	115	7680	1860	110	398	1	1140		
	PT/PTN-500	500,000	2083	VI	18	130	10,390	2520	108	517	1-1/2	1140		
	PT/PTN-610	610,000	2542	VI	20	140	11,750	2315	112	631	1-1/2	1140		
	PT-952	952,000	3967	VI	21	145	12,170	2321	139	985	2	1140		
Vertical Delivery ③	V/VN-42	42,000	175	II	11	15	17	11	950	825	103	43	1/30	1050
	V/VN-59	59,000	246	II	14	19	21	14	1155	1005	111	61	1/30	1050
	V/VN-78	78,000	325	II	15	20	23	15	1590	1065	109	81	1/15	1050
	V/VN-95	95,000	396	II	15	20	23	15	1665	1120	118	98	1/15	1050
	V/VN-139	139,000	579	III	18	24	27	18	2660	1285	112	144	1/6	1075
	V/VN-161	161,000	671	IV	20	27	30	20	2945	1420	115	167	1/3	1075
	V/VN-193	193,000	804	IV	22	30	33	22	3500	1690	116	200	1/3	1075
	V/VN-212	212,000	883	IV	22	30	33	22	3610	1740	120	219	1/3	1075
	V/VN-247	247,000	1029	V	26	34	39	26	4820	1910	111	256	1/2	1075
	V/VN-279	279,000	1163	V	30	37	45	30	5460	2165	111	289	1/2	1075
	V/VN-333	333,000	1388	V	30	37	45	30	5980	2165	116	345	3/4	1140
	V/VN-385	385,000	1604	VI	30	36	45	30	7680	1860	110	398	1	1140
	V/VN-500	500,000	2083	VI	37	44	56	37	10,390	2520	108	517	1-1/2	1140
V/VN-610	610,000	2542	VI	36	43	54	36	11,750	2315	112	631	1-1/2	1140	
V-952	952,000	3967	VI	37	45	56	56	12,170	2321	139	985	2	1140	

Table 8.2
Performance Data for Standard Units at Standard Conditions of 2 lb. Steam and 60°F Entering Air
Reduced Motor Speed ④

Type	Model No.	Btu/hr	Sq. Ft. EDR	Air Data							Motor Data	
				Sound Class ④	Maximum Mounting Height (ft.) ①	Heat Throw @ Max. Height ①	CFM ②	Outlet Velocity (Fpm)	Final Air Temp. (°F)	Condensate lb/hr	Hp	Approx. RPM
Horizontal Delivery	HSB/HC-18	14,000	58	I	8	10	220	415	118	14	1/60	1000
	HSB/HC-24	18,000	75	I	9	11	230	440	131	19	1/25	1000
	HSB/HC-33	25,000	104	I	10	13	395	440	118	26	1/25	1000
	HSB/HC-47	38,000	158	II	12	17	450	515	137	39	1/12	1000
	HSB/HC-63	47,000	195	II	14	17	685	430	122	49	1/12	1000
	HSB/HC-86	64,000	265	II	15	19	825	525	131	66	1/8	1000
	HSB/HC-108	81,000	340	II	17	19	1255	500	119	84	1/8	1000

① Horizontal units with horizontal louvers open 30° from vertical plane. Vertical types equipped with cone jet deflector, blades fully opened are shown in bold.

② CFM for horizontal types is entering CFM. CFM for vertical and Power Throw™ types is leaving CFM.

③ V and PT models have copper tubes, VN and PTN models have 90/10 cupro-nickel tubes.

④ Requires Solid State Motor Speed Controller.

STEAM PERFORMANCE DATA - LOW OUTLET TEMPERATURE MODELS

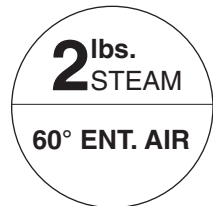

Table 9.1

Performance Data for Low Outlet Temperature Units at Standard Conditions of 2 lb. Steam and 60°F Entering Air High Motor Speed

Type	Model No.	Btu/hr	Sq. Ft. EDR	Air Data								Motor Data		
				Sound Class ④	Maximum Mounting Height (ft.) ①	Heat Throw or Spread @ Max. Height ①	CFM ②	Outlet Velocity (Fpm)	Final Air Temp. (°F)	Condensate lb/hr	Hp	Approx. RPM		
Horizontal Delivery ③	HSB/HC-18L	15,900	66	II	9	20	364	655	100	16	1/60	1550		
	HSB/HC-24L	19,300	80	II	11	21	435	795	100	20	1/25	1550		
	HSB/HC-33L	29,500	123	II	12	24	695	745	99	31	1/25	1550		
	HSB/HC-47L	32,000	133	III	14	32	855	910	94	33	1/12	1550		
	HSB/HC-63L	52,500	219	III	16	33	1170	710	101	54	1/12	1550		
	HSB/HC-86L	61,500	256	III	17	36	1510	910	97	64	1/8	1625		
	HSB/HC-108L	86,500	360	III	19	36	2150	825	97	90	1/8	1625		
	HSB/HC-121L	88,000	367	III	18	29	2070	800	98	91	1/5	1075		
	HSB/HC-165L	143,000	596	IV	21	45	3480	930	97	148	1/3	1075		
	HSB/HC-258L	190,000	792	V	22	51	4655	750	98	197	1/2	1075		
HSB/HC-290L	207,000	863	V	23	53	5040	805	94	214	1/2	1075			
HSB/HC-340L	255,000	1063	V	23	53	5575	775	102	264	1/2	1075			
Power Throw™ ③	PT/PTN-610L	470,000	1958	VI	22	154	2400	2445	97	486	1-1/2	1140		
Vertical Delivery ③	V/VN-42L	33,000	138	II	13	17	20	13	960	835	94	34	1/30	1050
	V/VN-59L	44,000	183	II	16	22	24	16	1190	1035	96	45	1/30	1050
	V/VN-78L	62,000	258	II	19	26	29	19	1740	1070	95	65	1/15	1050
	V/VN-95L	71,000	296	II	19	26	29	19	1760	1180	99	73	1/15	1050
	V/VN-139L	103,000	429	III	23	31	35	23	2860	1380	95	106	1/6	1075
	V/VN-161L	127,000	529	IV	26	35	39	26	3400	1640	96	132	1/3	1075
	V/VN-193L	149,000	621	IV	27	36	41	27	3710	1790	99	154	1/3	1075
	V/VN-212L	163,000	679	IV	27	36	41	27	3830	1845	102	169	1/3	1075
	V/VN-247L	190,000	792	V	32	42	48	32	5110	2030	96	197	1/2	1075
	V/VN-279L	215,000	896	V	36	45	54	36	5790	2300	96	222	1/2	1075
	V/VN-333L	256,000	1067	V	36	45	54	36	6340	2300	100	265	3/4	1140
	V/VN-385L	296,000	1233	VI	36	43	54	36	8140	1970	95	307	1	1140
	V/VN-500L	385,000	1604	VI	45	54	68	45	11,000	2670	94	400	1-1/2	1140
V/VN-610L	470,000	1958	VI	44	52	66	44	12,400	2445	97	485	1-1/2	1140	
V-952L	733,000	3055	VI	45	61	68	68	12,940	2450	115	759	2	1140	

Table 9.2

Performance Data for Low Outlet Temperature Units at Standard Conditions of 2 lb. Steam and 60°F Entering Air Reduced Motor Speed ④

Type	Model No.	Btu/hr	Sq. Ft. EDR	Air Data								Motor Data	
				Sound Class ④	Maximum Mounting Height (ft.) ①	Heat Throw @ Max. Height ①	CFM ②	Outlet Velocity (Fpm)	Final Air Temp. (°F)	Condensate lb/hr	Hp	Approx. RPM	
Horizontal Delivery	HSB/HC-18L	12,000	51	I	9	12	230	425	108	12	1/60	1000	
	HSB/HC-24L	14,400	60	1	11	13	265	490	109	15	1/25	1000	
	HSB/HC-33L	22,000	92	I	12	14	430	470	107	23	1/25	1000	
	HSB/HC-47L	24,300	101	II	14	19	540	580	101	25	1/12	1000	
	HSB/HC-63L	39,500	164	II	16	20	725	445	109	41	1/12	1000	
	HSB/HC-86L	46,000	192	II	17	22	925	565	105	48	1/8	1000	
	HSB/HC-108L	65,000	270	II	19	22	1330	520	104	67	1/8	1000	

① Horizontal units with horizontal louvers open 30° from vertical plane. Vertical types equipped with cone jet deflector, blades fully opened are shown in bold.

② CFM for horizontal types is entering CFM. CFM for vertical and Power Throw™ types is leaving CFM.

③ V and PT models have copper tubes, VN and PTN models have 90/10 cupro-nickel tubes.

④ Requires Solid State Motor Speed Controller.

HOT WATER PERFORMANCE DATA - STANDARD MODELS

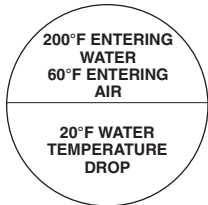

Table 10.1
Performance Data for Standard Units at Standard Conditions of 200°F Entering Water and 60°F Entering Air High Motor Speed

Type	Model No.	Btu/hr.	Water Data			Air Data						Motor Data			
			GPM	Pressure Drop (Ft. of Water)	Min/Max GPM	Sound Class ④	Maximum Mounting Height (ft.) ①	Heat Throw or Spread @ Max. Height ①	CFM ②	Outlet Velocity (Fpm)	Final Air Temp. (°F)	Hp	Approx. RPM		
Horizontal Delivery	HSB/HC-18	12,600	1.3	0.5	0.3 / 5.0	II	9	18	340	615	93	1/60	1550		
	HSB/HC-24	16,200	1.7	0.8	0.3 / 5.0	II	10	19	370	675	100	1/25	1550		
	HSB/HC-33	21,700	2.3	0.2	0.4 / 10.0	II	11	23	630	675	91	1/25	1550		
	HSB/HC-47	30,900	3.2	0.4	0.4 / 10.0	III	13	30	730	785	98	1/12	1550		
	HSB/HC-63	45,600	4.7	0.6	0.5 / 20.0	III	15	31	1120	680	97	1/12	1550		
	HSB/HC-86	60,200	6.3	1.0	0.5 / 20.0	III	16	33	1340	820	101	1/8	1625		
	HSB/HC-108	83,700	8.7	2.8	0.5 / 30.0	III	18	33	2010	775	98	1/8	1625		
	HSB/HC-121	93,000	9.7	3.3	0.7 / 30.0	III	17	27	1775	700	107	1/5	1075		
	HSB/HC-165	130,900	13.6	8.6	2.0 / 30.0	IV	20	43	3240	870	96	1/3	1075		
	HSB/HC-193	143,000	14.9	1.4	2.0 / 50.0	IV	19	41	2900	790	105	1/3	1075		
	HSB/HC-258	201,900	21.0	5.7	2.5 / 70.0	V	20	47	4560	740	100	1/2	1075		
HSB/HC-290	228,600	23.8	7.1	2.5 / 70.0	V	22	50	4590	750	105	1/2	1075			
HSB/HC-340	271,100	28.2	11.3	2.8 / 70.0	V	22	50	5130	720	108	1/2	1075			
Power Throw™ ③	PT/PTN-279	192,300	20.0	0.2	4.5 / 60.0	V	17	108	5460	2165	94	1/2	1075		
	PT/PTN-333	238,500	24.8	0.4	4.5 / 100.0	VI	18	117	5980	2165	99	3/4	1140		
	PT/PTN-385	276,100	28.8	0.6	4.5 / 100.0	VI	18	124	7680	1860	95	1	1140		
	PT/PTN-500	358,000	37.3	0.5	6.0 / 100.0	VI	19	138	10,390	2520	93	1-1/2	1140		
	PT/PTN-610	450,400	46.9	1.0	6.0 / 100.0	VI	22	151	11,750	2315	97	1-1/2	1140		
	PT-952	721,600	75.2	1.1	14.0 / 200.0	VI	23	150	12,166	2321	120	2	1140		
Vertical Delivery ③	V/VN-42	30,100	3.1	0.6	0.5 / 10.0	II	12	16	18	12	950	825	90	1/30	1050
	V/VN-59	42,600	4.4	0.5	0.8 / 15.0	II	15	20	22	15	1155	1005	96	1/30	1050
	V/VN-78	57,000	5.9	0.5	1.0 / 20.0	II	16	22	24	16	1590	1065	95	1/15	1050
	V/VN-95	69,300	7.2	0.5	1.3 / 25.0	II	16	22	24	16	1665	1120	101	1/15	1050
	V/VN-139	106,600	11.1	2.6	1.0 / 30.0	III	19	26	29	19	2660	1285	99	1/6	1075
	V/VN-161	123,200	12.8	2.2	1.3 / 40.0	IV	21	29	32	22	2945	1420	101	1/3	1075
	V/VN-193	147,200	15.3	2.2	1.5 / 50.0	IV	23	32	35	24	3500	1690	101	1/3	1075
	V/VN-212	161,700	16.8	1.5	2.0 / 60.0	IV	23	32	35	24	3610	1740	104	1/3	1075
	V/VN-247	188,700	19.7	2.1	2.0 / 60.0	V	28	37	41	28	4820	1910	98	1/2	1075
	V/VN-279	212,600	22.2	2.1	2.3 / 75.0	V	32	40	48	32	5460	2165	98	1/2	1075
	V/VN-333	260,100	27.1	3.8	2.8 / 75.0	V	32	40	48	32	5980	2165	102	3/4	1140
	V/VN-385	302,100	31.5	5.0	3.3 / 75.0	VI	32	39	48	32	7680	1860	98	1	1140
	V/VN-500	391,700	40.8	4.8	3.0 / 100.0	VI	39	47	59	40	10,390	2520	96	1-1/2	1140
	V/VN-610	450,400	46.9	1.0	6.0 / 100.0	VI	38	46	57	39	11,750	2315	97	1-1/2	1140
V-952	721,600	75.2	1.1	14.0 / 200.0	VI	39	63	59	70	12,166	2321	120	2	1140	

Table 10.2
Performance Data for Standard Units at Standard Conditions of 200°F Entering Water and 60°F Entering Air Reduced Motor Speeds ④

Type	Model No.	Btu/hr.	Water Data			Air Data					Motor Data	
			GPM	Pressure Drop (Ft. of Water)	Sound Class ④	Maximum Mounting Height (ft.) ①	Heat Throw @ Max. Height ①	CFM ②	Outlet Velocity (Fpm)	Final Air Temp. (°F)	Hp	Approx. RPM
Horizontal Delivery	HSB/HC-18	9900	1.3	0.5	I	9	11	220	400	101	1/60	1000
	HSB/HC-24	12,400	1.7	0.8	I	10	12	230	425	109	1/25	1000
	HSB/HC-33	16,700	2.3	0.2	I	11	14	395	430	98	1/25	1000
	HSB/HC-47	23,600	3.2	0.4	II	13	18	450	490	107	1/12	1000
	HSB/HC-63	34,600	4.7	0.6	II	15	18	685	420	106	1/12	1000
	HSB/HC-86	45,900	6.3	1.0	II	16	20	825	515	110	1/8	1000
	HSB/HC-108	64,300	8.7	2.8	II	18	20	1255	490	106	1/8	1000

① Horizontal units with horizontal louvers open 30° from vertical plane. Vertical types equipped with cone jet deflector, blades fully opened are shown in bold. Non-bolded mounting height/spread data is for units without deflectors.

② CFM for horizontal types is entering CFM. CFM for vertical and Power Throw™ types is leaving CFM.

③ V and PT models have copper tubes, VN and PTN models have 90/10 cupro-nickel tubes.

④ Requires Solid State Motor Speed Controller.

HOT WATER PERFORMANCE DATA - LOW OUTLET TEMPERATURE MODELS

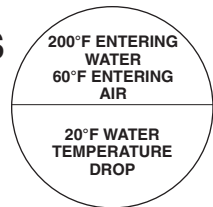

Table 11.1
Performance Data for Low Outlet Temperature Units at Standard Conditions of 200°F Entering Water and 60°F Entering Air – High Motor Speed

Type	Model No.	Btu/hr.	Water Data			Air Data						Motor Data			
			GPM	Pressure Drop (Ft. of Water)	Min/Max GPM	Sound Class ④	Maximum Mounting Height (ft.) ①	Heat Throw or Spread @ Max. Height ①	CFM ②	Outlet Velocity (Fpm)	Final Air Temp. (°F)	Hp	Approx. RPM		
Horizontal Delivery	HSB/HC-18L	11,300	1.2	0.4	0.3 / 5.0	II	10	21	364	650	88	1/60	1550		
	HSB/HC-24L	13,700	1.4	0.6	0.3 / 5.0	II	12	22	435	775	88	1/25	1550		
	HSB/HC-33L	19,300	2.0	0.2	0.4 / 10.0	II	13	26	695	730	85	1/25	1550		
	HSB/HC-47L	21,100	2.2	0.2	0.4 / 10.0	III	15	34	855	890	82	1/12	1550		
	HSB/HC-63L	37,900	4.0	0.4	0.5 / 20.0	III	17	35	1170	695	89	1/12	1550		
	HSB/HC-86L	44,600	4.6	0.6	0.5 / 20.0	III	18	38	1510	890	87	1/8	1625		
	HSB/HC-108L	66,100	6.9	1.8	0.8 / 30.0	III	20	38	2150	815	88	1/8	1625		
	HSB/HC-121L	66,700	6.9	1.9	0.8 / 30.0	III	19	31	2070	785	89	1/5	1075		
	HSB/HC-165L	113,200	11.8	6.6	2.0 / 30.0	IV	23	48	3480	920	89	1/3	1075		
	HSB/HC-258L	147,400	15.4	3.2	2.5 / 70.0	V	23	54	4655	735	89	1/2	1075		
HSB/HC-290L	161,100	16.8	3.7	2.5 / 70.0	V	25	57	5040	800	89	1/2	1075			
HSB/HC-340L	200,900	20.9	6.6	2.5 / 70.0	V	25	57	5575	760	93	1/2	1075			
Power Throw™ ③	PT/PTN-610L	344,900	35.9	0.6	6.0 / 100.0	VI	24	158	12,400	2445	86	1-1/2	1140		
Vertical Delivery ③	V/VN-42L	23,000	2.4	0.4	0.5 / 10.0	II	14	18	21	14	960	835	83	1/30	1050
	V/VN-59L	32,600	3.4	0.3	0.8 / 15.0	II	17	23	25	17	1190	1035	86	1/30	1050
	V/VN-78L	43,600	4.5	0.3	1.0 / 20.0	II	20	28	31	21	1740	1170	84	1/15	1050
	V/VN-95L	53,100	5.5	0.3	1.3 / 25.0	II	20	28	31	21	1760	1180	89	1/15	1050
	V/VN-139L	81,200	8.5	1.6	1.0 / 30.0	III	24	33	37	25	2860	1380	87	1/6	1075
	V/VN-161L	93,900	9.8	1.3	1.3 / 40.0	IV	28	37	41	28	3400	1640	86	1/3	1075
	V/VN-193L	112,500	11.7	1.3	1.5 / 50.0	IV	29	38	43	29	3710	1790	89	1/3	1075
	V/VN-212L	123,400	12.9	0.9	2.0 / 60.0	IV	29	38	43	29	3,830	1845	91	1/3	1075
	V/VN-247L	143,600	15.0	1.2	2.0 / 60.0	V	34	45	51	35	5110	2030	87	1/2	1075
	V/VN-279L	162,200	16.9	1.2	2.3 / 75.0	V	38	48	57	39	5790	2300	87	1/2	1075
	V/VN-333L	198,300	20.7	2.3	2.3 / 75.0	V	38	48	57	39	6340	2300	90	3/4	1140
	V/VN-385L	229,100	23.9	3.0	2.3 / 75.0	VI	38	46	57	49	8140	1970	87	1	1140
	V/VN-500L	295,000	30.7	2.8	3.0 / 100.0	VI	48	57	72	49	11,000	2670	85	1-1/2	1140
V/VN-610L	344,900	35.9	0.6	6.0 / 100.0	VI	47	55	70	48	12,400	2445	86	1-1/2	1140	
V-952L	546,700	56.9	0.7	14.0 / 100.0	VI	48	61	72	68	12,800	2440	102	2	1140	

Table 11.2
Performance Data for Low Outlet Temperature Units at Standard Conditions of 200°F Entering Water and 60°F Entering Air – Reduced Motor Speeds ④

Type	Model No.	Btu/hr.	Water Data			Air Data						Motor Data	
			GPM	Pressure Drop (Ft. of Water)	Sound Class ④	Maximum Mounting Height (ft.) ①	Heat Throw @ Max. Height ①	CFM ②	Outlet Velocity (Fpm)	Final Air Temp. (°F)	Hp	Approx. RPM	
Horizontal Delivery	HSB/HC-18L	8700	1.2	0.4	I	10	13	230	410	94	1/60	1000	
	HSB/HC-24L	10,400	1.4	0.6	I	12	14	265	475	95	1/25	1000	
	HSB/HC-33L	14,700	2.0	0.2	I	13	16	430	455	91	1/25	1000	
	HSB/HC-47L	16,300	2.2	0.2	II	15	21	540	570	87	1/12	1000	
	HSB/HC-63L	29,000	4.0	0.4	II	17	21	725	435	96	1/12	1000	
	HSB/HC-86L	33,900	4.6	0.6	II	18	23	925	550	93	1/8	1000	
	HSB/HC-108L	50,500	6.9	1.8	II	20	23	1330	510	94	1/8	1000	

① Horizontal units with horizontal louvers open 30° from vertical plane. Vertical types equipped with cone jet deflector, blades fully opened are shown in bold. Non-bolded mounting height/spread data is for units without deflectors.
 ② CFM for horizontal types is entering CFM. CFM for vertical and Power Throw™ types is leaving CFM.
 ③ V and PT models have copper tubes, VN and PTN models have 90/10 cupro-nickel tubes.
 ④ Requires Solid State Motor Speed Controller.

DIMENSIONAL DATA

Horizontal Air Delivery Models — Two Styles

Figure 12.1 - Model Dimensions HSB18-193

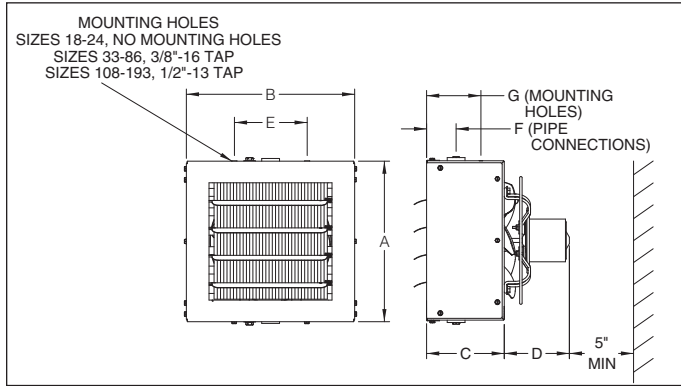

Figure 12.2 - Model Dimensions HSB258-340

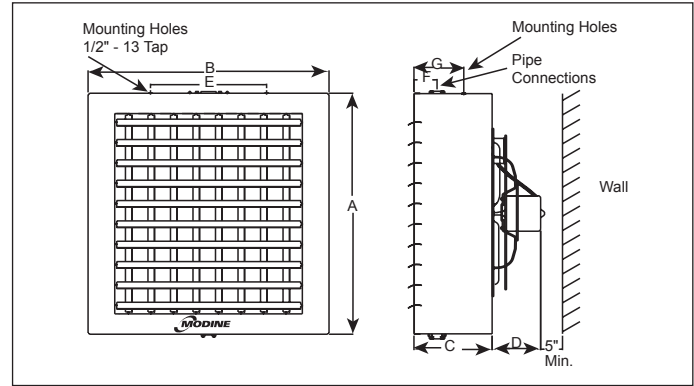

Figure 12.3 - Model Dimensions HC18-165

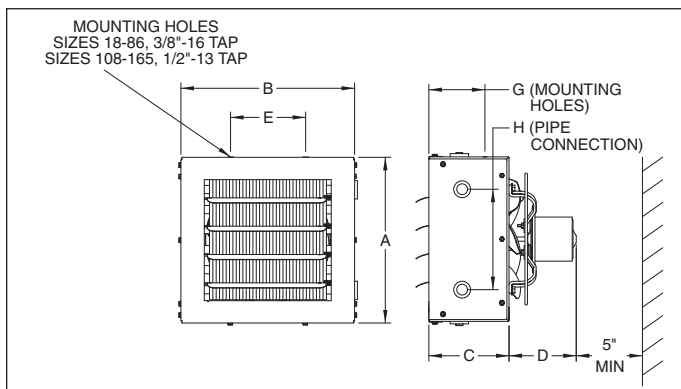
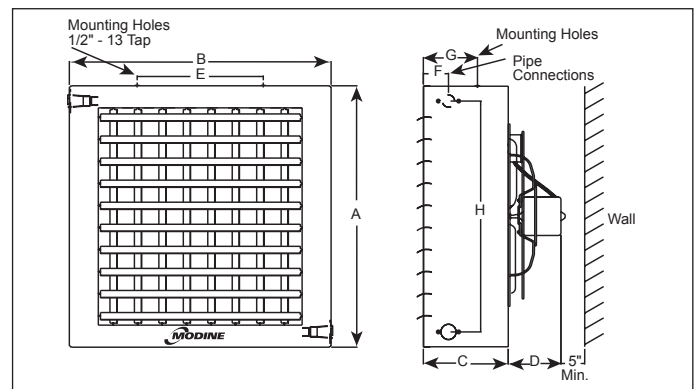

Figure 12.4 - Model Dimensions HC193-340 ①



① Vertical deflector blades shown are standard on models HC 258-340 and optional on model HC 193.

Table 12.1 - Model HSB and HC Dimensions ① ②

Model Number	A	B	C	D		E	F	G	H	Female Connections NPT	Fan Diameter	Approx. Shipping Wt. lb.
				115 Std. Motor	115V Exp. Motor							
HSB-18	12-3/8	13	6	5	12	-	3	-	-	3/4	9	16
HSB-24	12-3/8	13	6	6-1/2	12	-	3	-	-	3/4	9	20
HSB-33	16-3/8	17-1/2	8-3/4	6-1/2	12-1/4	11	3-5/8	6	-	1-1/4	12	34
HSB-47	16-3/8	17-1/2	8-3/4	8	12-1/4	11	3-5/8	6	-	1-1/4	12	36
HSB-63	20-7/16	21-1/2	8-3/4	8	12-3/4	15	3-5/8	6	-	1-1/4	14	48
HSB-86	20-7/16	21-1/2	8-3/4	9	12-3/4	15	3-5/8	6	-	1-1/4	14	52
HSB-108	24-7/16	25-1/2	9-1/2	8	11-1/2	18	3-3/4	6-3/8	-	1-1/4	18	74
HSB-121	24-7/16	25-1/2	9-1/2	7-1/2	11	18	3-3/4	6-3/8	-	1-1/4	18	76
HSB-165	30-1/2	30-1/2	9-1/4	9-1/2	14	21-1/4	3-3/4	6-3/8	-	1-1/4	22	92
HSB-193	30-1/2	30-1/2	9-1/4	9-1/2	14	21-1/4	3-3/4	6-3/8	-	1-1/4	22	98
HSB-258	38-1/2	38-1/2	12-1/2	10-1/2	14	18-1/2	3-5/8	7-7/8	-	1-1/4	22	162
HSB-290	38-1/2	38-1/2	12-1/2	10-1/2	14	18-1/2	3-5/8	7-7/8	-	1-1/4	24	168
HSB-340	38-1/2	44-1/2	12-1/2	10-1/2	14	18-1/2	3-5/8	7-7/8	-	1-1/4	24	176
HC-18	11-1/2	12-3/4	6	5	12	5-5/8	2-1/4	4-1/8	7-1/2	1/2	9	16
HC-24	11-1/2	12-3/4	6	6-1/2	12	5-5/8	2-1/4	4-1/8	7-1/2	1/2	9	20
HC-33	15	17-1/2	8-3/4	6-1/2	12-1/4	11	3-5/8	6	10	3/4	12	34
HC-47	15	17-1/2	8-3/4	8	12-1/4	11	3-5/8	6	10	3/4	12	35
HC-63	18-1/2	21-1/2	8-3/4	8	12-3/4	15	3-5/8	6	14	3/4	12	48
HC-86	18-1/2	21-1/2	8-3/4	9	12-3/4	15	3-5/8	6	14	3/4	14	52
HC-108	22-1/2	25-1/2	9-1/2	8	11-1/2	18	3-5/8	6-3/8	18	3/4	18	74
HC-121	22-1/2	25-1/2	9-1/2	7-1/2	11	18	3-5/8	6-3/8	18	3/4	18	76
HC-165	26-1/2	29-1/2	9-1/4	9-1/2	14	21-1/4	3-5/8	6-3/8	22	3/4	22	92
HC-193	30-1/2	32-1/2	9-1/4	9-1/2	14	21-1/4	3-5/8	4-3/4	26	1-1/4	22	98
HC-258	38-1/2	38-1/2	12-1/2	10-1/2	14	18-1/2	3-5/8	8	34	1-1/4	22	163
HC-290	38-1/2	38-1/2	12-1/2	10-1/2	14	18-1/2	3-5/8	8	34	1-1/4	24	168
HC-340	38-1/2	44-1/2	12-1/2	10-1/2	14	18-1/2	3-5/8	8	34	1-1/4	24	176

① All dimensions in inches.

② Dimensions shown are for Standard and Low Outlet Temperature Models.

DIMENSIONAL DATA

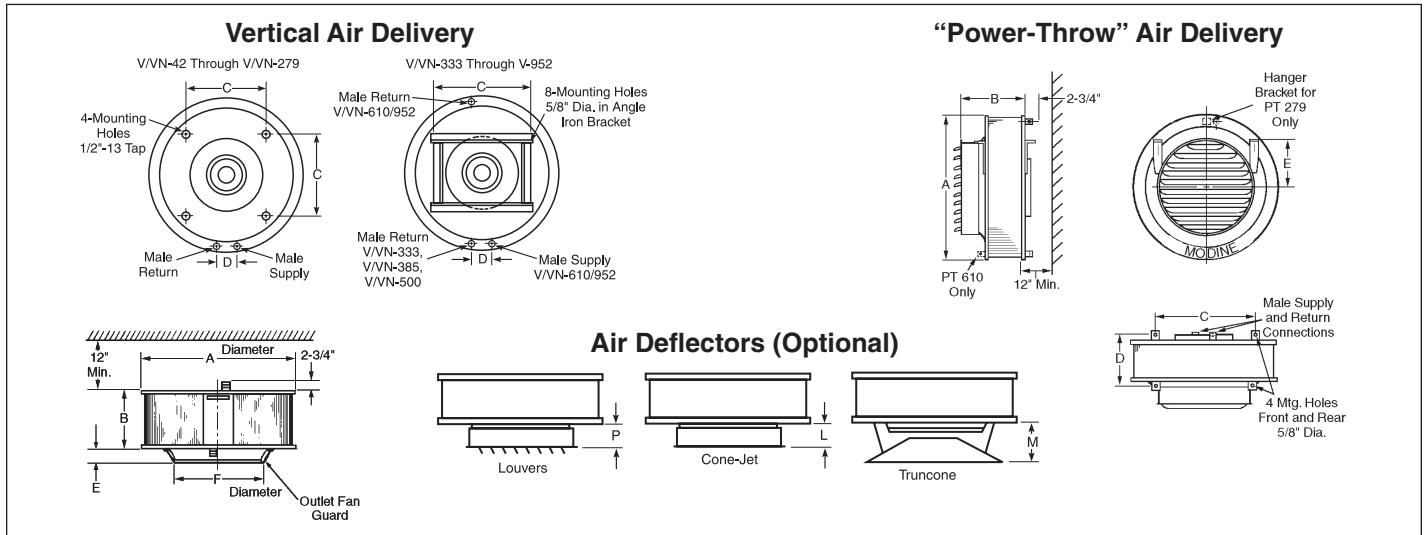

Table 13.1 - Model V/VN and PT/PTN Dimensions ① ② ③

Model Number	A	B	C	D	E	F	Fan G	Diameter	Male Connections NPT		Approx. Shipping Wt. (lb.)
									Top	Bottom	
V/VN-42	24-3/4	3-5/8	11-3/8	2-1/8	4-3/8	14-1/2	-	14	1-1/4	1-1/4	36
V/VN-59	24-3/4	5-1/8	11-3/8	2-1/8	4-3/8	14-1/2	-	14	1-1/4	1-1/4	42
V/VN-78	24-3/4	6-5/8	11-3/8	2-1/8	2-5/8	16-1/2	-	16	1-1/4	1-1/4	46
V/VN-95	24-3/4	8-1/8	11-3/8	2-1/8	2-5/8	16-1/2	-	16	1-1/4	1-1/4	48
V/VN-139	34-3/4	6-7/8	18-3/8	2-1/8	3	19-1/2	-	19	1-1/2	1	70
V/VN-161	34-3/4	8-3/8	18-3/8	2-1/8	3	19-1/2	-	19	1-1/2	1	80
V/VN-193	34-3/4	9-7/8	18-3/8	2-1/8	3	19-1/2	-	19	1-1/2	1	86
V/VN-212	34-3/4	12-7/8	18-3/8	2-1/2	3	19-1/2	-	19	2	1-1/4	94
V/VN-247	34-3/4	12-7/8	18-3/8	2-1/2	3	21-1/2	-	21	2	1-1/4	108
V/VN-279	34-3/4	14-3/8	18-3/8	2-1/2	3	21-1/2	-	21	2	1-1/4	112
V/VN-333	43-1/4	14-5/8	31-1/2	2-7/8	3-1/8	22-1/2	18-1/5	22	2-1/2	1-1/2	166
V/VN-385	43-1/4	14-1/2	31-1/2	2-7/8	3-1/2	27-1/2	18-1/5	27	2-1/2	1-1/2	168
V/VN-500	43-1/4	19	31-1/2	2-7/8	3-1/2	27-1/2	18-1/5	27	2-1/2	1-1/2	360
V/VN-610	51-1/2	19-1/8	31-3/8	-	3-3/4	30-1/2	31-3/8	30	2-1/2	1-1/2	450
V-952	53-3/4	21-1/8	30	-	3-1/2	31	30	30	3	3	487
PT/PTN-279	34-3/4	22-5/8	25-1/4	16-3/4	16-3/4	-	-	21	2	1-1/4	122
PT/PTN-333	43-1/4	23-7/8	30	15-3/4	14-3/8	-	-	22	2-1/2	1-1/2	176
PT/PTN-385	43-1/4	25-3/4	30	15-3/4	14-3/8	-	-	27	2-1/2	1-1/2	184
PT/PTN-500	43-1/4	29	30	20-1/4	14-3/8	-	-	27	2-1/2	1-1/2	376
PT/PTN-610	51-1/2	29-5/8	30	20-3/8	21	-	-	30	2-1/2	1-1/2	472
PT-952	53-3/4	26-3/8	30	23-1/8	26-7/8	-	-	30	3	3	487

- ① All dimensions in inches.
- ② Dimensions shown are for Standard and Low Outlet Temperature Models.
- ③ See Table 13.2 for optional air outlet accessory dimensions.

Table 13.2 - Vertical Air Outlet Accessories Dimensions ①

Model Number	Cone-Jet		Truncone		Louvers	
	L	T	M	X	P	Z
V-42, V-59	6-1/2	18-7/8	12	22	6-1/2	16-7/8
V-78, V-95	6-1/2	18-7/8	12	22	6-1/2	16-7/8
V-139, V-212	7-1/2	24-3/4	13	27	7-1/2	19-3/4
V-247, V-279	8	26-7/8	16	34	8	22-3/4
V-333	8-1/2	28	16	34	8-1/2	22-3/4
V-385, V-500	10	22-3/4	21	41	10	27-3/4
V-610	10-1/2	36-3/4	21	41	10-1/2	30-3/4
V-952	-	-	-	-	19-1/2	32

- ① All dimensions in inches.

MOTOR DATA / SERVICE

Table 14.1 - Motor Amp Draw Data ① ②

Model Number	Motor HP ③	Amp Draw by Motor Type, Voltage and Power Code							
		Totally Enclosed						Explosion Proof	
		115/60/1	208/60/1	230/60/1	208/60/3	230/460/3	575/60/3	115/60/1	230/460/60/3
01	N/A	02	04	05	10	06	09		
HSB/HC-18	1/60	0.8	④	0.44	④	④	④	3.1	-
HSB/HC-24, 33	1/25	1.6	④	1	④	④	④	3.1	-
HSB/HC-47, 63	1/12	2.2	④	1	④	1.4/0.4 ⑤	④	3.1	-
HSB/HC-86, 108	1/8	2.3	④	1	④	1.4/0.4 ⑤	④	3.1	-
HSB/HC-121	1/5	2.8	④	1.5	1.9 ⑤	2.1/1.05 ⑤	④	4.1	1.5/0.75
HSB/HC-165, 193	1/3	5.4	④	2.23	1.9 ⑤	2.1/1.05 ⑤	④	6.1	1.5/0.75
HSB/HC-258-340	1/2	7.5	④	3.5	2.6 ⑤	3.0/1.5 ⑤	④	5.8	2.0/1.0
V/VN-42, 59	1/30	1.9	④	1.28	1.9 ⑤	2.1/1.05 ⑤	④	4.1	-
V/VN-78, 95	1/15	2.4	④	1.28	1.9 ⑤	2.1/1.05 ⑤	④	4.1	-
V/VN-139	1/5	2.8	④	1.5	1.9 ⑤	2.1/1.05 ⑤	④	4.1	1.5/.75
V/VN-161-212	1/3	5.4	④	2.23	1.9 ⑤	2.1/1.05 ⑤	④	6.1	1.5/.75
V/VN-247	1/2	7.5	④	3.5	2.6 ⑤	3.0/1.5 ⑤	④	5.8	2.0/1.0
V/VN, PT/PTN-279	1/2	7.5	④	3.5	2.6 ⑤	3.0/1.5 ⑤	④	5.8	2.0/1.0
V/VN, PT/PTN-333	3/4	8.8	④	4.4	3.7 ⑤	3.5/1.8 ⑤	④	-	-
V/VN, PT/PTN-385	1	-	-	-	4	4.0/2.0	1.5	-	3.5/1.75
V/VN, PT/PTN-500, 610	1-1/2	-	-	-	5.8	5.2/2.6	2	-	5.8/2.9

① Ratings shown are for Standard and Low Outlet Temperature Models.

② All motors include thermal overload protection except for units with Power Code 04, 05, or 10.

③ All HSB/HC units, V/VN-42 thru V/VN,PT/PTN-333 motor HP listed for power code 01. V/VN,PT/PTN333 thru V/VN,PT/PTN610 motor HP listed for power code 04 and V/PT-952 motor HP listed for power code 05.

④ For supply voltages of 208V/60Hz/1ph and all non-explosion proof 3 phase voltages of 208, 230, 460 and 575, Model Numbers indicated with Note ④, require that a 115V/60Hz/1 phase Power Code 01 unit heater be used with a shipped loose accessory transformer. See literature #1-556 for Transformer Sizes. See Note ⑤.

⑤ Model Numbers indicated with Note ⑤, can be ordered with a Power Code (208V/3ph=04, 230/460V/3ph=05) that provides a motor matched to the supply voltage with amp draw as shown. Alternately, a 115V/60Hz/1 phase Power Code 01 unit heater could be used with a shipped loose accessory transformer. See literature #1-556 for Transformer Sizes.

SERVICE

WARNING

When servicing or repairing this equipment, use only factory-approved service replacement parts. A complete replacement parts list may be obtained by contacting Modine Manufacturing Company. Refer to the rating plate on the unit for complete unit substitution of parts or controls not approved by the factory will be at the owner's risk.

CAUTION

1. Servicing or repairing of this equipment must be performed by a qualified service agency.
2. Do not reuse any electrical component which has been wet. Replace component.

IMPORTANT

To check most of the Possible Remedies in the troubleshooting guide listed in Table 15.1, refer to the applicable sections of the manual.

Heating equipment should be serviced before each heating season to assure proper operations. The following items may be required more frequently based on the environment in which the unit is installed and frequency of equipment operation.

All installation and service of these units must be performed by a qualified installation and service agency.

Before any service, BE SURE TO TURN OFF THE STEAM OR WATER SUPPLY AT THE MANUAL SHUT-OFF VALVES AND TURN OFF ALL ELECTRIC POWER TO THE HEATER.

Motors

1. Remove grease and dirt on motor during each inspection or lubrication. Open frame motors should be blown clean every heating season, or whenever coils are cleaned, whichever is sooner.
2. Lubricate motor according to manufacturer's instructions located on the motor. When no motor oiling instructions are on the motor, oil the motor every two thousand hours of operation with SAE20 motor oil for units in normal applications. Adjust oiling according to usage and atmosphere.
3. Some motors do not have oil fittings. These motors are lubricated for long life and do not require further lubrication.
4. A change in line voltage higher or lower than motor nameplate rating may cause overheating and serious motor damage. Check plant voltage conditions. A separate manual starter with thermal overload protection device is recommended for those units that do not have motors with built-in overload protection.

Coils

1. Clean coil at least once a year; more often under unfavorable conditions. Unless coil is kept reasonably free of dirt, lint and grease, its original heating capacity will be reduced — possibly to a serious degree, and motor damage may result.

Two commonly used cleaning methods are:

- Loosen dirt by brushing fins on side where air enters coil and then turn on fan to blow dirt from unit.
- Use high pressure air hose to loosen dirt by blowing from side where air leaves coil (side adjacent to louvers on blow-through units; side adjacent to fan on draw-through units).

SERVICE / TROUBLESHOOTING

- For thorough cleaning of coil, remove motor and fan and spray a mild alkaline cleaning solution over the coil. After a few minutes, follow by a hot water rinse. (A steam gun can be used for spraying cleaning solution and hot water.)
- Coils subjected to corrosive fumes should be checked and cleaned frequently.
- Provide controlled water treatment — don't use excess of boiler compounds. Contact your boiler compound supplier for proper usage or the services of a water treatment laboratory.
- Periodic internal flushing of the coils is recommended in areas where water supply is suspected of causing scale. Use an alkaline-chelant solution and introduce it at the main pump of the hydronic system. Flush thoroughly.

WARNING: USING INORGANIC OR MINERAL ACIDS SUCH AS MURIATIC (HYDROCHLORIC) ACID, EVEN THOUGH INHIBITED, MAY LEAD TO SEVERE DAMAGE, INCLUDING CORROSION AND LEAKAGE.

- De-aerate boiler feed-water (particularly if large amount of new water is used).
- Insure rapid continuous and adequate condensate drainage by properly sized and installed traps and piping. Check traps for sticking. Clean strainers ahead of traps. (When traps don't work, condensate accumulates in unit heater coil; water hammer results.)
- Adequately vent each unit.
- Use low pressure steam when possible.

Table 15.1 - Troubleshooting

<p>Fails to Maintain Temperature</p> <ol style="list-style-type: none"> Undersized unit heater, boiler, pump or piping. Unit heater operating at low speed when sized for high speed. Unit heater mounted too high — heated air not delivered to floor. Thermostat — improper location or setting, or not functioning. Dirty or clogged coil. <p>Unit Blows Cold Air</p> <ol style="list-style-type: none"> Manual shut-off valve closed. Insufficient steam pressure or lack of hot water. Aquastat not functioning. Improper venting. Steam trap not functioning. Drip leg too short (steam system). Return line plugged (steam system). Pump undersized or not operating (hot water system). <p>Does Not Operate When Heat Needed</p> <ol style="list-style-type: none"> Defective motor or electrical connections. Thermostat, aquastat or pressure limit control not functioning. <p>Fails to Deliver Heat to Floor</p> <ol style="list-style-type: none"> Units mounted too high. Operating on low speed. Final air temperature too high. Louvers not adjusted properly. Wrong type of diffuser (on verticals). Undersized unit heater (insufficient air delivery). Wrong type of unit (may require vertical delivery). Cross ventilation or drafts. Obstructions to air flow. 	<p>Noisy Unit</p> <ol style="list-style-type: none"> Loose bolts or screws. Fan blade bent, out of balance. Dirt accumulation on fan blades. Fan hub or blade rivets loose. Motor shaft bearing worn. Motor mounting bent, fan not positioned properly in venturi. Conduit too rigid, transmits vibration noise. BX cable touching unit heater, chatters as casing vibrates. <p>Employees Complain of Hot Blast</p> <ol style="list-style-type: none"> Air stream aimed directly at employees. Louvers not adjusted properly. Wrong type of diffuser (on verticals). Excessive final air temperature. <p>Unit Operates Too Long</p> <ol style="list-style-type: none"> Thermostat installed on cold wall or other improper location. Aquastat or pressure limit control not functioning properly. Unit is undersized. <p>Frequent Motor Failure</p> <ol style="list-style-type: none"> Voltage fluctuations too high or too low. Excessive or insufficient lubrication. Wiring to motor undersized. Improper electrical connections. Motor operating in too high air temperature. Restricted air flow due to clogged coil or closed louvers. Fan out of balance. Unbalanced voltage on 3ϕ power. <p>Coil Failure/Unit Leaks</p> <ol style="list-style-type: none"> Severe internal corrosion from feedwater. Type of boiler treatment. Entrained air causing water hammer. Continuous operation above 150 PSI (375°F)(steam systems). Loose connection.
--	--

Casings

- Periodic cleaning of casings is recommended to remove dirt, grease and corrosive substances that may injure finish. Rusted or corroded spots should be cleaned and repainted.
- Tighten fan guard and motor bracket. Check fan for proper clearance, free rotation and firm connection to shaft.
When servicing is complete, tag unit to indicate date of inspection, lubrication and cleaning.

Replacement Parts

When requesting parts please contact your local representative. Please have full model and serial number available. See Figure 15.1.

Figure 15.1 - Model Identification Plate

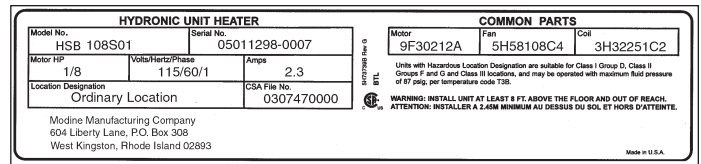

COMMERCIAL WARRANTY

Seller warrants its products to be free from defects in material and workmanship, EXCLUSIVE, HOWEVER, of failures attributable to the use of materials substituted under emergency conditions for materials normally employed. This warranty covers replacement of any parts furnished from the factory of Seller, but does not cover labor of any kind and materials not furnished by Seller, or any charges for any such labor or materials, whether such labor, materials or charges thereon are due to replacement of parts, adjustments, repairs, or any other work done. This warranty does not apply to any equipment which shall have been repaired or altered outside the factory of Seller in any way so as, in the judgment of Seller, to affect its stability, nor which has been subjected to misuse, negligence, or operating conditions in excess of those for which such equipment was designed. This warranty does not cover the effects of physical or chemical properties of water or steam or other liquids or gases used in the equipment.

BUYER AGREES THAT SELLER'S WARRANTY OF ITS PRODUCTS TO BE FREE FROM DEFECT IN MATERIAL AND WORKMANSHIP, AS LIMITED HEREIN, SHALL BE IN LIEU OF AND EXCLUSIVE OF ALL OTHER WARRANTIES, EITHER EXPRESS OR IMPLIED, WHETHER ARISING FROM LAW, COURSE OF DEALING, USAGE OF TRADE, OR OTHERWISE, THERE ARE NO OTHER WARRANTIES, INCLUDING WARRANTY OF MERCHANTABILITY OR FITNESS FOR PURPOSE, WHICH EXTEND BEYOND THE PRODUCT DESCRIPTION CONFIRMED BY BUYER AND SELLER AS OF THE DATE OF FINAL AGREEMENT.

This warranty is void if the input to the product exceeds the rated input as indicated on the product serial plate by more than 5% on gas-fired and oil-fired units, or if the product in the judgment of SELLER has been installed in a corrosive atmosphere, or subjected to corrosive fluids or gases, been subjected to misuse, negligence, accident, excessive thermal shock, excessive humidity, physical damage, impact, abrasion, unauthorized alterations, or operation contrary to SELLER'S printed instructions, or if the serial number has been altered, defaced or removed.

BUYER AGREES THAT IN NO EVENT WILL SELLER BE LIABLE FOR COSTS OF PROCESSING, LOST PROFITS, INJURY TO GOODWILL, OR ANY OTHER CONSEQUENTIAL OR INCIDENTAL DAMAGES OF ANY KIND RESULTING FROM THE ORDER OR USE OF ITS PRODUCT, WHETHER ARISING FROM BREACH OF WARRANTY, NONCONFORMITY TO ORDERED SPECIFICATIONS, DELAY IN DELIVERY, OR ANY LOSS SUSTAINED BY THE BUYER.

BUYER'S REMEDY FOR BREACH OF WARRANTY, EXCLUSIVE OF ALL OTHER REMEDIES PROVIDED BY LAW, IS LIMITED TO REPAIR OR REPLACEMENT AT THE FACTORY OF SELLER, ANY COMPONENT WHICH SHALL, WITHIN THE APPLICABLE WARRANTY PERIOD DEFINED HEREIN AND UPON PRIOR WRITTEN APPROVAL, BE RETURNED TO SELLER WITH TRANSPORTATION CHARGES PREPAID AND WHICH THE EXAMINATION OF SELLER SHALL DISCLOSE TO HAVE BEEN DEFECTIVE; EXCEPT THAT WHEN THE PRODUCT IS TO BE USED BY BUYER AS A COMPONENT PART OF EQUIPMENT MANUFACTURED BY BUYER, BUYER'S REMEDY FOR BREACH, AS LIMITED HEREIN, SHALL BE LIMITED TO ONE YEAR FROM DATE OF SHIPMENT FROM SELLER. FOR GAS-FIRED PRODUCTS INSTALLED IN HIGH HUMIDITY APPLICATIONS AND UTILIZING STAINLESS STEEL HEAT EXCHANGERS, BUYER'S REMEDY FOR BREACH, AS LIMITED HEREIN, SHALL BE LIMITED TO TEN YEARS FROM DATE OF SHIPMENT FROM SELLER.

These warranties are issued only to the original owner-user and cannot be transferred or assigned. No provision is made in these warranties for any labor allowance or field labor participation. Seller will not honor any expenses incurred in its behalf with regard to repairs to any of Seller's products. No credit shall be issued for any defective part returned without proper written authorization (including, but not limited to, model number, serial number, date of failure, etc.) and freight prepaid.

OPTIONAL SUPPLEMENTAL WARRANTY

Provided a supplemental warranty has been purchased, Seller extends the warranty herein for an additional four (4) years on certain compressors. Provided a supplemental warranty has been purchased, Seller extends the warranty herein for an additional four (4) years or nine (9) years on certain heat exchangers.

EXCLUSION OF CONSUMABLES & CONDITIONS BEYOND SELLER'S CONTROL

This warranty shall not be applicable to any of the following items: refrigerant gas, belts, filters, fuses and other items consumed or worn out by normal wear and tear or conditions beyond Seller's control, including (without limitation as to generality) polluted or contaminated or foreign matter contained in the air or water utilized for heat exchanger (condenser) cooling or if the failure of the part is caused by improper air or water supply, or improper or incorrect sizing of power supply.

Component Applicable Models	"APPLICABLE WARRANTY PERIOD"
Heat Exchangers Gas-Fired Units except PSH/BSH	TEN YEARS FROM DATE OF FIRST BENEFICIAL USE BY BUYER OR ANY OTHER USER, WITHIN TEN YEARS FROM DATE OF RESALE BY BUYER OR ANY OTHER USER, WITHIN TEN YEARS FROM DATE OF RESALE BY BUYER IN ANY UNCHANGED CONDITION, OR WITHIN ONE HUNDRED TWENTY-SIX MONTHS FROM DATE OF SHIPMENT FROM SELLER, WHICHEVER OCCURS FIRST
Heat Exchangers Low Intensity Infrared Units Compressors Condensing Units for Cassettes	FIVE YEARS FROM DATE OF FIRST BENEFICIAL USE BY BUYER OR ANY OTHER USER, WITHIN FIVE YEARS FROM DATE OF RESALE BY BUYER OR ANY OTHER USER, WITHIN FIVE YEARS FROM DATE OF RESALE BY BUYER IN ANY UNCHANGED CONDITION, OR WITHIN SIXTY-SIX MONTHS FROM DATE OF SHIPMENT FROM SELLER, WHICHEVER OCCURS FIRST
Burners Low Intensity Infrared Units Other Components excluding Heat Exchangers, Coils, Condensers, Burners, Sheet Metal	TWO YEARS FROM DATE OF FIRST BENEFICIAL USE BY BUYER OR ANY OTHER USER, WITHIN TWO YEARS FROM DATE OF RESALE BY BUYER IN ANY UNCHANGED CONDITION, OR WITHIN THIRTY MONTHS FROM DATE OF SHIPMENT FROM SELLER, WHICHEVER OCCURS FIRST
Heat Exchangers/Coils Indoor and Outdoor Duct Furnaces and System Units, PSH/BSH, Steam/Hot Water Units, Oil-Fired Units, Electric Units, Cassettes, Vertical Unit Ventilators Compressors Vertical Unit Ventilators Burners High Intensity Infrared Units Sheet Metal Parts All Products	ONE YEAR FROM DATE OF FIRST BENEFICIAL USE BY BUYER OR ANY OTHER USER, WITHIN ONE YEAR FROM DATE OF RESALE BY BUYER IN ANY UNCHANGED CONDITION, OR WITHIN EIGHTEEN MONTHS FROM DATE OF SHIPMENT FROM SELLER, WHICHEVER OCCURS FIRST

As Modine Manufacturing Company has a continuous product improvement program, it reserves the right to change design and specifications without notice.



Commercial Products Group

Modine Manufacturing Company
 1500 DeKoven Avenue
 Racine, WI 53403
 Phone: 1.800.828.4328 (HEAT)
 www.modine.com
 Litho in USA