

Steam/Hot Water Unit Heaters



Horizontal Delivery
Side Connections



Horizontal Delivery
Top and Bottom
Connections



Vertical Delivery



Power-Throw™
Horizontal High
Velocity Delivery

HORIZONTAL AIR DELIVERY MODELS

Dimensions - Models HSB/HC

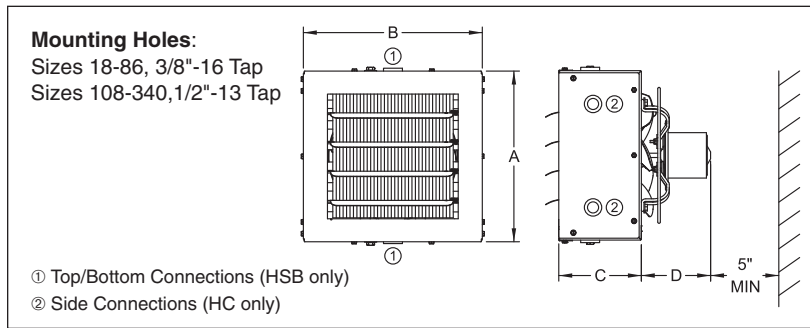

Model Size	HSB		HC		C	D ③	Approx. Weight (lbs)
	A	B	A	B			
18 & 24	12.38	13.00	11.50	13.00	6.00	5.00	16 & 20
33 & 47	16.38	17.50	15.00	17.50	8.75	6.00	34 & 36
63 & 86	20.44	21.50	18.50	21.50	8.75	7.75	48 & 52
108 & 121	24.44	25.50	22.50	25.50	9.50	6.75	74 & 76
165	30.50	30.50	26.50	29.50	9.25	8.50	92
193	30.50	30.50	30.50	32.50	9.25	8.50	98
258 & 290	38.50	38.50	38.50	38.50	12.50	10.00	162 & 168
340	38.50	44.50	38.50	44.50	12.50	10.00	176

③ Dimensions shown apply to standard 115V/1ph motor (Power Code 01).



Model HSB



Model HC

HSB and HC models feature the following:

- Squared off corners for a clean, smooth appearance.
- HSB models have top and bottom supply and return steel connections.
- HC models have a copper tube and copper coil connections located on the side for low clearance applications.
- A two piece casing for quick access to coil.
- An electric junction box for easy electrical connections.
- Baked on gray-green, electrostatically applied polyester powdercoat, environmentally friendly paint.
- Motors are totally enclosed with thermal overload protection.
- Low outlet temperature models for higher steam pressures or dirty atmospheres.
- Listed by the Canadian Standards Association and CRN registered heat exchanger.



Performance Data (60°F Entering Air Temperature)

Model Number	Motor HP	Standard Models							Low-Outlet Temperature Models						
		Steam (2# Steam)		Hot Water (200°F In, 180°F Out)			CFM	Max. Mtg. Height (Ft)	Heat Throw @ Max. Mtg. Height (Ft)	Steam (2# Steam)					
		Btu/Hr	Final Air Temp. (°F)	Btu/Hr	Water Flow (GPM)	Final Air Temp. (°F)				Model Number	Btu/Hr	CFM	Final Air Temp. (°F)	Max. Mtg. Height (Ft)	Heat Throw @ Max. Mtg. Height (Ft)
HSB/HC 18	1/60	18,000	107	12,560	1.3	94	340	9	18	HSB/HC 18L	15,900	364	100	9	20
HSB/HC 24	1/25	24,000	119	16,250	1.7	100	370	10	19	HSB/HC 24L	19,300	435	100	11	21
HSB/HC 33	1/25	33,000	108	21,680	2.3	91	630	11	22	HSB/HC 33L	29,500	695	99	12	24
HSB/HC 47	1/12	47,000	119	30,940	3.2	98	730	13	30	HSB/HC 47L	32,000	855	94	14	32
HSB/HC 63	1/12	63,000	111	45,580	4.7	97	1120	15	31	HSB/HC 63L	52,500	1170	101	16	33
HSB/HC 86	1/8	86,000	118	60,210	6.3	101	1340	16	33	HSB/HC 86L	61,500	1510	97	17	36
HSB/HC 108	1/8	108,000	109	83,740	8.7	98	2010	18	33	HSB/HC 108L	86,500	2150	97	19	36
HSB/HC 121	1/5	121,000	122	93,000	9.7	108	1775	17	27	HSB/HC 121L	88,000	2070	98	18	29
HSB/HC 165	1/3	165,000	106	130,950	13.6	97	3240	20	43	HSB/HC 165L	143,000	3480	97	21	45
HSB/HC 193	1/3	193,000	121	143,000	14.9	105	2900	19	40	—	—	—	—	—	—
HSB/HC 258	1/2	258,000	111	201,950	21	100	4560	20	47	HSB/HC 258L	190,000	4655	98	22	51
HSB/HC 290	1/2	290,000	117	228,620	23.8	105	4590	21	49	HSB/HC 290L	207,000	5040	94	23	53
HSB/HC 340	1/2	340,000	120	271,110	28.2	108	5130	21	49	HSB/HC 340L	255,000	5575	102	23	53

③ Dimensions shown apply to standard 115V/1ph motor (Power Code 01).

VERTICAL AIR DELIVERY MODELS

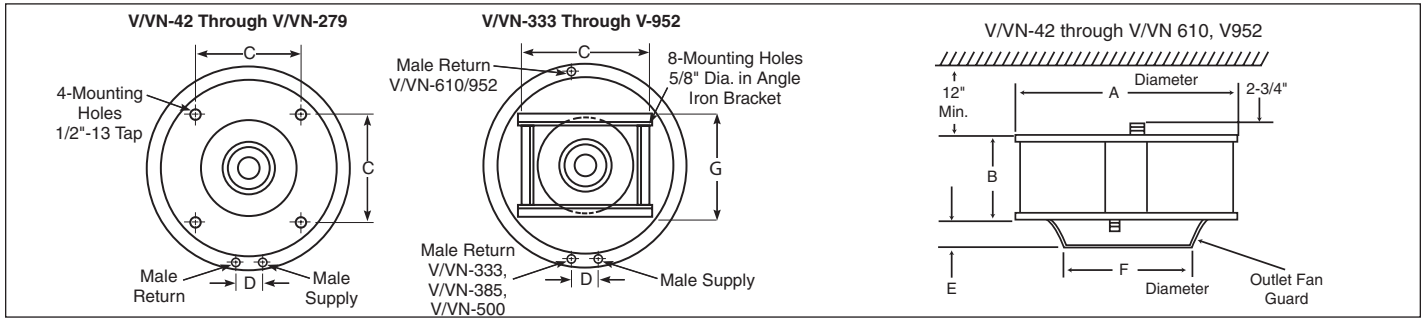

Models V/VN Dimensions - Inches

Model Number	A	B	C	D	E	F	G	Fan Dia.	Male Conn. NPT		Approx. Shipping Wt. (lbs.)
									Top	Bottom	
V/VN-42	24-3/4	3-5/8	11-3/8	2-1/8	4-3/8	14-1/2	-	14	1-1/4	1-1/4	36
V/VN-59	24-3/4	5-1/8	11-3/8	2-1/8	4-3/8	14-1/2	-	14	1-1/4	1-1/4	42
V/VN-78	24-3/4	6-5/8	11-3/8	2-1/8	2-5/8	16-1/2	-	16	1-1/4	1-1/4	46
V/VN-95	24-3/4	8-1/8	11-3/8	2-1/8	2-5/8	16-1/2	-	16	1-1/4	1-1/4	48
V/VN-139	34-3/4	6-7/8	18-3/8	2-1/8	3	19-1/2	-	19	1-1/2	1	70
V/VN-161	34-3/4	8-3/8	18-3/8	2-1/8	3	19-1/2	-	19	1-1/2	1	80
V/VN-193	34-3/4	9-7/8	18-3/8	2-1/8	3	19-1/2	-	19	1-1/2	1	86
V/VN-212	34-3/4	12-7/8	18-3/8	2-1/2	3	19-1/2	-	19	2	1-1/4	94
V/VN-247	34-3/4	12-7/8	18-3/8	2-1/2	3	21-1/2	-	21	2	1-1/4	108
V/VN-279	34-3/4	14-3/4	18-3/8	2-1/2	3	21-1/2	-	21	2	1-1/4	112
V/VN-333	43-1/4	14-1/2	24	2-7/8	3-1/8	22-1/2	18-1/5	22	2-1/2	1-1/2	166
V/VN-385	43-1/4	14-1/2	24	2-7/8	3-1/2	27-1/2	18-1/5	27	2-1/2	1-1/2	168
V/VN-500	43-1/4	19	24	2-7/8	3-1/2	27-1/2	18-1/5	27	2-1/2	1-1/2	360
V/VN-610	51-1/2	19-1/8	24	—	3-3/4	30-1/2	31-3/8	30	2-1/2	1-1/2	450
V-952	53-3/4	21-1/4	30	—	3-1/2	31	30	30	3	3	487



Model V and VN

V and VN models feature the following:

- V models have copper tubes, VN models have copper/nickel tubes for high temperature and/or pressure applications.
- Low outlet temperature models for higher steam pressures or dirty atmospheres.
- All units provided with outlet fan guard.
- Motor cooling cone shields motor from heat for longer life.
- Optional air deflectors, Cone Jet, Truncone and Louvers for a variety of heat throw patterns.
- All units include an electric junction box for easy electrical connections.
- Baked on grey-green, electrostatically applied polyester powdercoat, environmentally friendly paint.
- All units are listed by the Canadian Standards Association and CRN registered heat exchanger.



Performance Data (60°F Entering Air Temperature)

Model Number	Motor HP	Standard Models							Low-Outlet Temperature Models						
		Steam (2# Steam)		Hot Water (200°F In, 180°F Out)			*Max. Mtg. Height (Ft)	*Heat Spread @ Max. Mtg. Height (Ft)	Steam (2# Steam)						
		Btu/Hr	Final Air Temp. (°F)	Btu/Hr	Water Flow (GPM)	Final Air Temp. (°F)			CFM	Btu/Hr	CFM	Final Air Temp. (°F)	*Max. Mtg. Height (Ft)	*Heat Spread @ Max. Mtg. Height (Ft)	
V/VN 42	1/30	42,000	103	30,100	3.1	90	950	16	12	V/VN 42L	33,000	960	94	17	13
V/VN 59	1/30	59,000	111	42,640	4.4	96	1155	20	15	V/VN 59L	44,000	1190	96	22	16
V/VN 78	1/15	78,000	109	56,960	5.9	95	1590	21	16	V/VN 78L	62,000	1740	95	26	19
V/VN 95	1/15	95,000	118	69,300	7.2	101	1665	21	16	V/VN 95L	71,000	1760	99	26	19
V/VN 139	1/5	139,000	112	106,600	11.1	99	2660	26	19	V/VN139L	103,000	2860	95	31	23
V/VN 161	1/3	161,000	115	123,220	12.8	101	2945	29	21	V/VN 161L	127,000	3400	96	35	26
V/VN 193	1/3	193,000	116	147,200	15.3	101	3500	32	23	V/VN 193L	149,000	3710	99	36	27
V/VN 212	1/3	212,000	120	161,680	16.8	104	3610	32	23	V/VN 212L	163,000	3830	102	36	27
V/VN 247	1/2	247,000	111	188,700	19.7	98	4820	36	28	V/VN 247L	190,000	5110	96	42	32
V/VN 279	1/2	279,000	111	212,650	22.2	98	5460	39	32	V/VN 279L	215,000	5790	96	45	36
V/VN 333	3/4	333,000	116	260,080	27.1	103	5980	39	32	V/VN 333L	256,000	6340	100	45	36
V/VN 385	1	385,000	110	302,080	31.5	98	7680	38	32	V/VN 385L	296,000	8140	95	43	36
V/VN 500	1-1/2	500,000	108	391,690	40.8	97	10,390	47	39	V/VN 500L	385,000	11,000	94	54	45
V/VN 610	1-1/2	610,000	112	450,420	46.9	97	11,750	46	38	V/VN 610L	470,000	12,400	97	52	44
V 952	2	952,000	139	721,640	75.2	120	12,170	39	60	V 952L	733,300	12,940	115	61	68

③ Dimensions shown apply to standard 115V/1ph motor (Power Code 01). *Vertical types equipped with cone jet deflector, except V952 which is without deflector.

POWER-THROW™ HIGH VELOCITY HORIZONTAL AIR DELIVERY MODELS

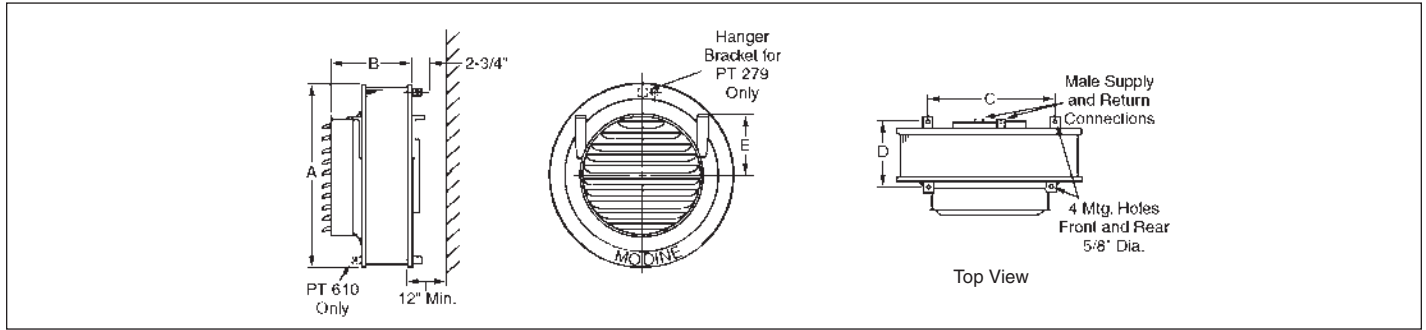

Dimensions - Inches

Model Number	A	B	C	D	E	Fan Diameter	Male Conn. NPT		Approx. Shipping Wt. (lbs.)
							Top	Bottom	
PT/PTN 279	34-3/4	22-5/8	25-1/4	16-3/4	16-3/4	21	2	1-1/4	122
PT/PTN 333	43-1/4	23-7/8	30	15-3/4	14-3/8	22	2-1/2	1-1/2	176
PT/PTN 385	43-1/4	25-3/4	30	15-3/4	14-3/8	27	2-1/2	1-1/2	184
PT/PTN 500	43-1/4	29	30	20-1/4	14-3/8	27	2-1/2	1-1/2	376
PT/PTN 610	51-1/2	29-5/8	30	20-3/8	21	30	2-1/2	1-1/2	472
PT 952	53-3/4	29-5/8	30	23-1/8	26-7/8	30	3	3	487



Model PT and PTN

PT and PTN models feature the following:

- PT models have copper tubes, PTN models have copper/nickel tubes for high temperature and/or pressure applications.
- High capacity models with powerful, high velocity air delivery.
- All units provided with horizontal air deflector blades.
- Ideal for blanketing large frequently opened doors with heated air.
- Distributes heat over a wide area — can often replace several smaller units.
- All units include an electric junction box for easy electrical connections.
- Baked on grey-green, electrostatically applied polyester powdercoat, environmentally friendly paint.
- All units are listed by the Canadian Standards Association and CRN registered heat exchanger.



Performance Data (60°F Entering Air Temperature)

Model Number	Standard Models									Low-Outlet Temperature Models					
	Motor HP	Steam (2# Steam)		Hot Water (200°F In, 180°F Out)			CFM	Max. Mtg. Height (Ft)	Heat Throw @ Max. Mtg. Height (Ft)	Model Number	Steam (2# Steam)				
		Btu/Hr	Final Air Temp. (°F)	Btu/Hr	Water Flow (GPM)	Final Air Temp. (°F)					Btu/Hr	CFM	Final Air Temp. (°F)	Max. Mtg. Height (Ft)	Heat Throw @ Max. Mtg. Height (Ft)
PT/PTN 279	1/2	279,000	111	192,350	20.0	94	5460	17	106	—	—	—	—	—	
PT/PTN 333	3/4	333,000	116	238,480	24.8	99	5980	18	117	—	—	—	—	—	
PT/PTN 385	1	385,000	110	276,080	28.8	95	7680	18	122	—	—	—	—	—	
PT/PTN 500	1-1/2	500,000	108	357,960	37.3	93	10,390	19	138	—	—	—	—	—	
PT/PTN 610	1-1/2	610,000	112	450,420	46.9	97	11,750	21	149	PT/PTN 610L	470,000	12400	97	22	154
PT 952	2	952,000	139	721,610	75.2	120	12,170	22	154	—	—	—	—	—	

③ Dimensions shown apply to standard 115V/1ph motor (Power Code 01).



Commercial Products Group
 Modine Manufacturing Company
 1500 DeKoven Avenue
 Racine, Wisconsin 53403-2552
 Phone: 1.800.828.4328 (HEAT)
 Fax: 1.800.204.6011