

Hybrid Flex Inverter System

2. TROUBLE SHOOTING

2. TROUBLESHOOTING

2-1 Service maintenance for Hybrid Flex Inverter System

2-1-1 Features

Enhanced installability and maintenance.

<Product>

- 1) Multi-room --> Many pipes and lines
- 2) Branch box --> Pipes and line
- 3) Increased power supply points --> Outdoor units and branch boxes

<Functions>

- The conditions of each lines are automatically checked.
- Controller in outdoor units.
- 7-segment lamp in outdoor units.

● Check operation

- Lines and pipes of branch boxes are automatically checked.
- Check result (Fault and right lines) is shown.

● Controller in outdoor units

[Available]

- Cooling and heating test running
- Refrigerant recovery mode
- Local setting function (Outdoor unit function)

● Display in outdoor units

[Available]

- Cooling and heating running condition
- Detail and unit number of error
- Speed of compressor and outdoor fan
- Value detected from sensor

2-1-1 Error code

1) New error codes are adopted.

Lamp flashing, wired remote control, outdoor unit 7-segment (number).

Checked by alphabet.

Current "EE" --> New "Er"

※ Shown in wired remote control, temperature setting.

2) Hybrid Flex Inverter System, error codes

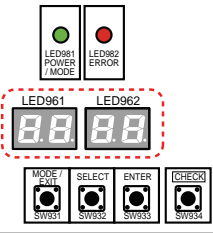
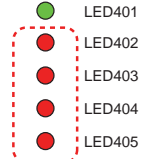
	Error code display	Defective component	Appearance	Object person
Indoor unit	Indoor units lamps, flashing of operation and timer lamps. and continuous flashing of economy lamp.	- Indoor unit error - Abnormal units except indoor units	<input type="radio"/> OPERATION (Green) <input type="radio"/> TIMER (Orange) <input type="radio"/> ECONOMY (Green)	- End user - Installer - Service engineer
Wired remote control	LCD, 7-segment display			
Outdoor unit	Four 7-segment lamps on PCB	- Outdoor unit error - Abnormal units except outdoor units (Indoor unit, Branch-box)		- Service engineer - Installer
Branch box	Four lamps on PCB	- Branch box error, *No exception		

2-1-3 Response procedure at error code display

Case1 : End user

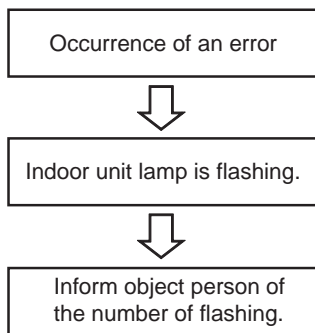

Case2 : Service Engineer

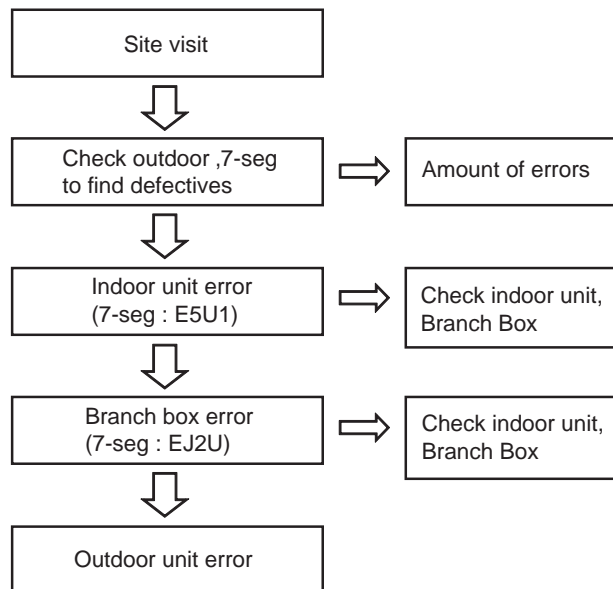

Case3 : Error at construction

After performing the below-described work, repairs, inspections etc., always carry out the Check operation. Normal operation will not be possible without performing the Check operation.

1. Things to confirm before starting the Check operation

To ensure safety, check that the following work, inspections and operations have been completed.

- 1 Check that all work on the piping connecting the outdoor unit , indoor units and branch box has been completed
- 2 Check that all work on the wiring connecting the outdoor unit, indoor units and branch box has been completed
- 3 Is there a gas leakage? (At pipe connections {flang connections and brazed areas})
- 4 Is the system changed with the specified volume of refrigerant?
- 5 Is a breaker installed at the power supply cable of outdoor unit and every branch boxes?
- 6 Are the wires connected to the terminals without looseness, and in accordance with the specifications?
- 7 Is the 3-way valve of the outdoor unit open?(Gas pipe and liquid pipe)
- 8 Is power supplied to the crank case heater for more than 12 hours?
- 9 Has the power supply of the all indoor units turned off?(Remote controller)

2. Restrictions applicable when performing the Check operation

- When the Check run starts, all indoor units connected to the outdoor unit will start to run automatically. During the Check run, you cannot check the operation of the indoor units separately. After the Check run, check the operation of the indoor units separately in normal operation.
- The operable temperature ranges for the Check run are: external temperature -15 to 46°C(5 to 115°F); room temperature for cooling 18 to 46°C(64 to 114°F); room temperature for heating -15 to 37°C(5 to 98°F).
- In the check run, the conditioner will automatically switch between cooling and heating depending on the external temperature and internal temperature.
If the external temperature or internal temperature is outside the above operable temperature range, wait until the temperature is within the operable range and then perform the Check run.
- The Check run can be completed within 1 hour, but may take several hours depending on the external and internal temperature conditions etc.
- Please do not conduct the Check run with all the windows in the room closed. Otherwise the room temperature could get too low or too high.
- Depending on the difference of the room temperature of each room, a judgment may be impossible.

3. Operating procedure for Check run

(●: On, ◎: Blinking, ○: Off)







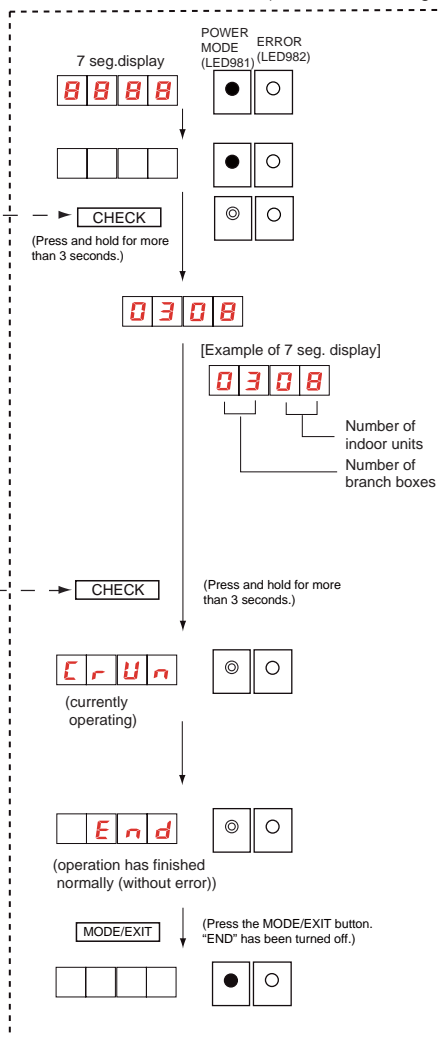

- (1) Turn power on to the outdoor unit, indoor units and branch boxes.
After the displayed number of "8888." has been turned off, press the "CHECK" button.(approximately 2 minutes)
- (2) Press and hold the "CHECK" BUTTO for more than 3 seconds.
- (3) The number of connected branch boxes and indoor units will be displayed on the 7 seg. display. Check that the displayed number matches the actual number of connected units. Do not perform the Check run if the displayed number of units is in error. If the Check run was performed with the number of units in error, check the state of the units and then perform the Check run again.
 - 1 If the displayed number of units matches the installed number, go to (4)
 - 2 If the displayed number does not match the installed number, check the following.
 - Are all the Branch boxes turned on? → Check that the Branch boxes are turned on, and go to (4).
 - Are connection cables connected to all of the indoor units? → Turn of the power, connect the Connection cable and go to (1).
- (4) Press and hold the "CHECK" button again for more than 3 seconds.
 - The Check run will start.

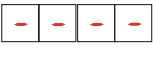
In the Check run, the following items will be checked.

 - 1 The wiring and piping between the indoor units and the Branch box
 - 2 Valve opening
 - To make an enforced stop, press the "MODE/EXIT" button. You cannot execute the stop operation using the remote control.
 - To prevent electric shock, close the service panel during the Check run.
- (5) The Check run will stop automatically after allitems are completed. When an error occurs, consult the following error display items. Correct the error, and carry out the Check run again.
 - When the error display disappear even the measures for error are taken, switch on the power again after turning off the power. When the power is turned on again after turned off, wait approx. 10 minutes and turn on the power again.

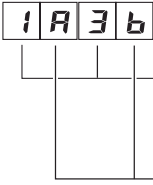

4. Error display







Error display		Error item	Contents
(●: On, ◎: Blinking, ○: Off)			
7 seg. display	LED lamp		
 (blinking)		Indeterminable	The external or room temperature is outside the operable range. The air conditioner will temporarily permit normal operation, but the Check run should be carried out again at a later date when the temperatures are within the operable ranges.
		Wiring number error	The number of wirings between indoor unit and branch box is not correct. Turn off all the units, and check number of connected wires. After correcting the error, turn on the power and carry out the Check run again.
		Pipe number error	The number of wirings between indoor unit and branch box is not correct. Turn off all the units, and check number of connected wires. After correcting the error, turn on the power and carry out the Check run again. ※ If the number of pipes is correct, the internal heat-exchanger thermistor or branch box piping thermistor may have come out of its holder, or a coil may have come out of an expansion valve. In this case, please contact Service personnel.
(example)		Wiring error	A wiring error has occurred. The location at which the wiring error has been determined will be displayed 7 seg. display. If there are multiple wiring error locations, the display will cycle through the locations, switching every 2 seconds. After performing the following operation, turn off the power and correct the wiring. <ul style="list-style-type: none"> • Note down the content of the wiring error. • Note down the number of blinks of the green LED on the PCB of the branch box. (The number of blinks indicates the device number of the Branch box) After correcting the wiring, turn on the power and carry out the Check run again. <p>(In the case of the diagram) Connect the connection cable which is connected to the terminal A of Branch box (Primary) to the terminal B on Branch box (Secondary 2).</p>  <ul style="list-style-type: none"> 1: Branch box-Primary 2: Branch box-Secondary 1 3: Branch box-Secondary 2 a: Branch box-TerminalA b: Branch box-TerminalB c: Branch box-TerminalC
		unit error	This is a unit error. * For error content, please refer to "11.2. Error display mode".

2-2 NORMAL OPERATION

2-2-1 Normal status for Indoor Unit Display

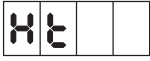
Indication type	Indication Lamp	Flashing Pattern
Operation	Operation LED	Continuous lighting
Timer	Timer LED	Continuous lighting
Filter Sign	Economy LED	<p>ON OFF</p> <p>21 sec</p> <p>0.8 sec</p> <p>1 cycle</p>
Power Failure	Operation LED	<p>ON OFF</p> <p>0.5 sec</p> <p>0.5 sec</p>
	Timer LED	<p>ON OFF</p> <p>0.5 sec</p> <p>0.5 sec</p>
Test Operation	Operation LED	<p>ON OFF</p> <p>1 sec</p> <p>1 sec</p>
Compulsion Cooling	Timer LED	<p>ON OFF</p> <p>1 sec</p> <p>1 sec</p>
Defrosting	Operation LED	<p>ON OFF</p> <p>7 sec</p> <p>2 sec</p>
Oil Recovery		
Mode Mismatch	Operation LED	<p>ON OFF</p> <p>1 sec</p> <p>1 sec</p>
Maintenance Mode	Operation LED	<p>ON OFF</p> <p>1 sec</p> <p>1 sec</p>
	Timer LED	
	Economy LED	

2-2-2 Normal status for Outdoor Unit Display

Indication type	7 Segment LED Pattern	Description
Idling(stop)	 Blank	
Cooling Mode	 "C" OO "L"	During Cooling Mode
Heating Mode	 "H" EA "T"	During Heating Mode
Oil Recovery Operation	 "O" IL "R" ECOVERY	During Oil Recovery Operation
Defrost Operation	 "D" E "F" ROST	During Defrost Operation
Power Saving Operation	 "P" eak "C" ut	During Power Saving Operation
Low Noise Operation	 "L" OW "N" OISE	During Low Noise Operation

2-2-3. Normal status for Branch Box Display

Green	Red				Comment
LED401	LED402	LED403	LED404	LED405	
●	○	○	○	○	The branch box is functioning properly.

● : Lit

○ : Unlit

2-3 ABNORMAL OPERATION

2-3-1 Error status for Indoor Unit Display

Please refer the flashing pattern as follows.

The OPERATION, TIMER, ECONOMY lamps operate as follows according to the error contents.

Error Contents	Operation LED	Timer LED	Economy LED	Trouble shooting
Serial Communication Error	1 times flash	1 times flash	Continuous flash	1, 37 ~ 39
Wired Remote Controller Communication Error	1 times flash	2 times flash	Continuous flash	2
Check Run Unfinished	1 times flash	5 times flash	Continuous flash	3
Number of Wires and Pipes Error	2 times flash	1 times flash	Continuous flash	
Indoor Unit Capacity Error	2 times flash	2 times flash	Continuous flash	4
Connected Combination Error	2 times flash	3 times flash	Continuous flash	5
Number of Indoor Units Error Number of Branch boxes Error	2 times flash	4 times flash	Continuous flash	6,7
Indoor Unit Model Information Error EEPROM Access Abnormal	3 times flash	2 times flash	Continuous flash	8
Manual Auto Switch Error	3 times flash	5 times flash	Continuous flash	9
Indoor Room Thermistor Error	4 times flash	1 times flash	Continuous flash	10
Indoor Heat Ex. Thermistor Error	4 times flash	2 times flash	Continuous flash	11
Indoor Unit Fan Motor Error	5 times flash	1 times flash	Continuous flash	12
Drainage Error	5 times flash	3 times flash	Continuous flash	13
Damper Error	5 times flash	7 times flash	Continuous flash	47
Intake Grille Error	5 times flash	8 times flash	Continuous flash	48
Outdoor Unit Model Information Error	6 times flash	2 times flash	Continuous flash	14
Inverter Error	6 times flash	3 times flash	Continuous flash	15
A. F. Voltage Error	6 times flash	4 times flash	Continuous flash	16
Display P.C.B. Communication Error	6 times flash	10 times flash	Continuous flash	46
Discharge Thermistor Error	7 times flash	1 times flash	Continuous flash	17
Compressor Thermistor Error	7 times flash	2 times flash	Continuous flash	18
Heat Ex. Liquid Outlet Thermistor Error	7 times flash	3 times flash	Continuous flash	19
Outdoor Thermistor Error	7 times flash	4 times flash	Continuous flash	20
Suction Gas Thermistor Error	7 times flash	5 times flash	Continuous flash	21
Heat Sink Thermistor Error	7 times flash	7 times flash	Continuous flash	22

Error Contents	Operation LED	Timer LED	Economy LED	Trouble shooting
Sub-Cool Heat Ex.Gas Inlet Thermistor Error Sub-Cool Heat Ex.Gas Outlet Thermistor Error	8 times flash	2 times flash	Continuous flash	23, 24
Liquid Pipe Thermistor Error	8 times flash	3 times flash	Continuous flash	25
Current Sensor Error	8 times flash	4 times flash	Continuous flash	26
Discharge Pressure Sensor Error Suction Pressure Sensor Error High Pressure Switch Error	8 times flash	6 times flash	Continuous flash	27, 28, 29
Over Current Error	9 times flash	4 times flash	Continuous flash	30
Compressor Control Error	9 times flash	5 times flash	Continuous flash	31
Outdoor Unit Fan Motor Error	9 times flash	7 times flash </td <td>Continuous flash</td> <td>32</td>	Continuous flash	32
4 Way Valve Error	9 times flash	9 times flash	Continuous flash	33
Discharge Temp. Error	10 times flash	1 times flash	Continuous flash	34
Compressor Temp. Error	10 times flash	3 times flash	Continuous flash	35
Low Pressure Error	10 times flash	5 times flash	Continuous flash	36
Branch Box Error	13 times flash	2 times flash	Continuous flash	1, 40 ~ 45

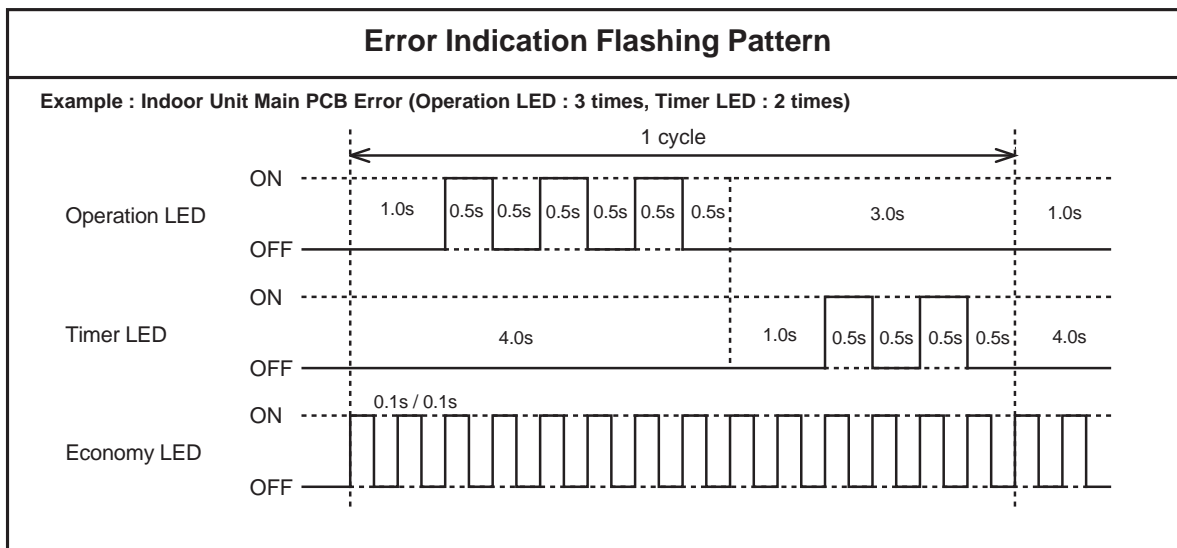

2-3-2 Remote Controller Display

<< SIMPLE REMOTE CONTROLLER >>

ERROR CODE DISPLAY

If an error occurs, the following display will be shown.
 ("Er" will appear in the set room temperature display.)
 If "Er" is displayed, immediately contact authorized service personnel.

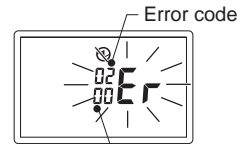

Faulty unit No.
 (Remote controller address)
 Ex. Error code display

<< WIRED REMOTE CONTROLLER >>

ERROR CODE DISPLAY

If an error occurs, the following display will be shown.
 ("Er" will appear in the set room temperature display.)
 If "Er" is displayed, immediately contact authorized service personnel.

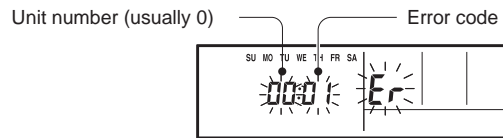

Ex. Error code display

<< HOME CONTROLLER >>

ERROR DISPLAY

To show which indoor unit is the error displayed,
 indoor unit's name and "ERROR" are alternately shown.
 (0.5s indoor unit's name / 0.5s "ERROR")

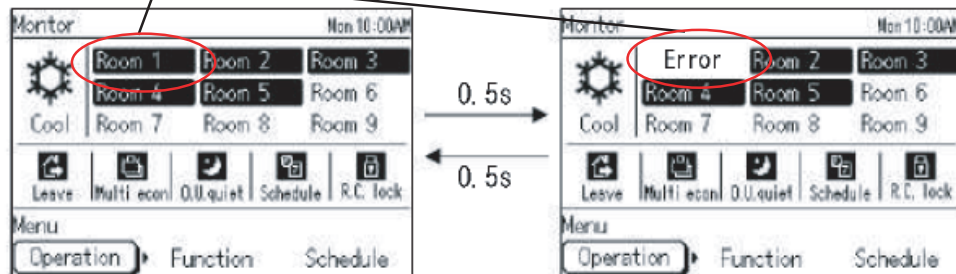

Ex. Error display

2-3-3 Error Code List for Simple and Wired Remote Controller

Error Code	Error Contents	Trouble shooting
1 1	Serial Communication Error	1,37 ~ 39
1 2	Wired Remote Controller Communication Error	2
1 5	Check Run Unfinished	3
2 1	Number of Wires and Pipes Error	
2 2	Indoor Unit Capacity Error	4
2 3	Connected Combination Error	5
2 4	Number of Indoor Units Error Number of Branch boxes Error	6, 7
3 2	Indoor Unit Model Information Error EEPROM Access Abnormal	8
3 5	Manual Auto Switch Error	9
4 1	Indoor Room Thermistor Error	10
4 2	Indoor Heat Ex. Thermistor Error	11
5 1	Indoor Unit Fan Motor Error	12
5 3	Drainage Error	13
5 7	Damper Error	47
5 8	Intake Grille Error	48
6 2	Outdoor Unit Model Information Error	14
6 3	Inverter Error	15
6 A	Display P.C.B. Communication Error	46
7 1	Discharge Thermistor Error	17
7 2	Compressor Thermistor Error	18
7 3	Heat Ex. Liquid Outlet Thermistor Error	19
7 4	Outdoor Thermistor Error	20
7 5	Suction Gas Thermistor Error	21
7 7	Heat Sink Thermistor Error	22

Error Code	Error Contents	Trouble shooting
8 2	Sub-Cool Heat Ex.Gas Inlet Thermistor Error Sub-Cool Heat Ex.Gas Outlet Thermistor Error	23, 24
8 3	Liquid Pipe Thermistor Error	25
8 4	Current Sensor Error	26
8 6	Discharge Pressure Sensor Error Suction Pressure Sensor Error High Pressure Switch Error	27,28,29
9 4	Over Current Error	30
9 5	Compressor Control Error	31
9 7	Outdoor Unit Fan Motor Error	32
9 9	4 Way Valve Error	33
A 1	Discharge Temp. Error	34
A 3	Compressor Temp. Error	35
A 5	Low Pressure Error	36
J 2	Branch Box Error	1,40 ~ 45

2-3-4 Outdoor Unit Display

LED display

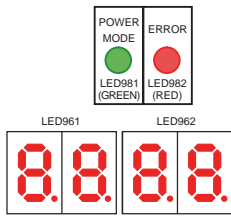

POWER MODE LED : on
ERROR LED : flashing

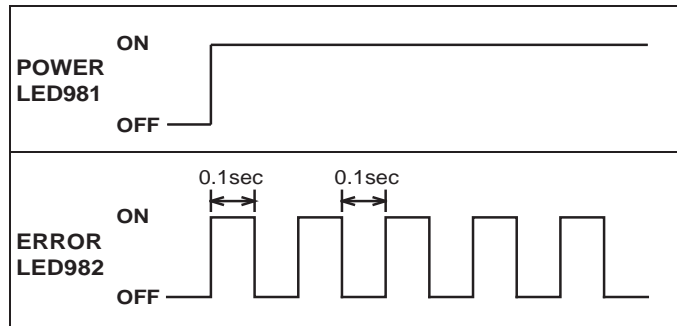







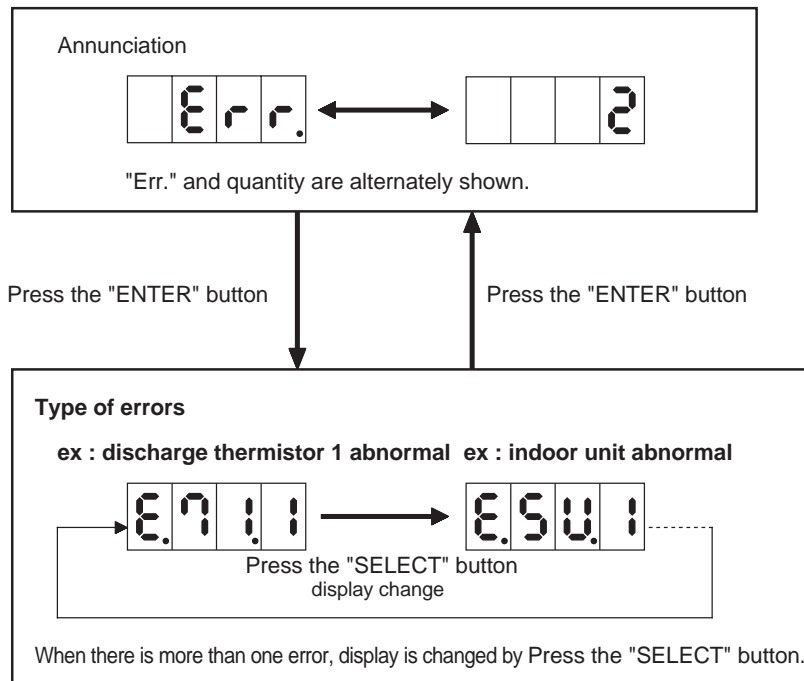







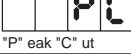

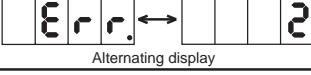



Operation button

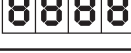

ERROR transition

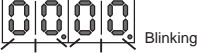

If some error is newly occurred or resolved during transition, it is reflected after going back to "Annunciation".

Indication type	7 Segment LED Pattern	Description
Idling(stop)	 Blank	
Cooling mode	 "C" "OO" "L"	During Cooling mode
Heating mode	 "H" "EA" "T"	During Heating mode
Oil recovery operation	 "O" "IL" "R" "ECOVERY"	During Oil recovery operation. Refer to 01-25 page for operation.
Defrost operation	 "D" "E" "F" "ROST"	During Defrost operation. Refer to 01-22 page for operation.
Power saving operation	 "P" "eak" "C" "ut"	During Power saving operation. Refer to 01-29 page for operation.
Low noise operation	 "L" "OW" "N" "OISE"	During Low noise operation. Refer to 01-29 page for operation.
Error display mode (Number of errors occurred)	ex.  Alternating display	Number of errors occurred are displayed. (Ex. Two error codes present.) Refer to 02-11 page for details.
Error display mode (Error code)	ex. 	Error codes are displayed. (Ex. Discharge thermistor error) Refer to 02-11 page for details.
Running the vacuum/ pump down mode	 "RUN"	Vacuum/ Pump down mode running.
End of the function	 "DONE"	The function is finished normally. (Function is "Test-run start/ stop" and "EEPROM memory clear".)
Performing function failed	 "FAIL"	The function can not be performed.
Power off	 "P" "OWER" "OFF"	When "P.oFF" is displayed, turn off the power supplies of all units.
Preparation display		Number of "8888" is displayed for 2 minutes after power on.
Connected units display (Only for Check run)	ex. 	
Running Check.	 "C" "HECK" "RUN"	Wiring check in Check run is performing.
End of Check run	 "END"	Check run is finished.
Memory clear	 Blinking	Number "0000" is blinking for 1 minute when the memory is cleared after Check run is finished.
Error display for Check run (Wiring number error)	 "P" "IPE" ">" "L" "INE"	Number of wirings between indoor unit and branch box is not correct.
Error display for Check run (Pipe number error)	 "P" "IPE" "<" "L" "INE"	Number of pipes between indoor unit and branch box is not correct.
Error display for Check run (Wiring error)	ex. 	Wiring error has occurred. (Ex. Connection of Terminal A on the primary BB to Terminal B on secondary 2 BB is wrong.)
Indeterminable	 Blinking	The external or room temperature is outside the operating range of Check run.

2-3-5 Error Code List for Outdoor Unit Display

Error Code	Error Contents	Trouble shooting
E. 1 1. 3	Serial communication error	1, 37 ~ 39
E. 1 1. 4	Serial communication error	1, 37 ~ 39
E. 1 5. 6	Check run unfinished	3
E. 2 1. 2	Number of wires and pipes error	
E. 2 2. 1	Indoor unit capacity error	4
E. 2 4. 2	Number of indoor units error	6
E. 2 4. 3	Number of Branch boxes error	7
E. 5 U. 1	Indoor Unit error	8 ~ 13,47,48
E. 6 2. 1	Outdoor unit model information error	14
E. 6 3. 1	Inverter error	15
E. 6 4. 1	A.F. voltage error	16
E. 6 A. 1	Display P.C.B. Communication Error	46
E. 7 1. 1	Discharge thermistor error	17
E. 7 2. 1	Compressor thermistor error	18
E. 7 3. 3	Heat Ex. Liquid outlet thermistor error	19
E. 7 4. 1	Outdoor thermistor error	20
E. 7 5. 1	Suction gas thermistor error	21
E. 7 7. 1	Heat sink thermistor error	22

Error Code	Error Contents	Trouble shooting
E. 8 2. 1	Sub cool heat EX. gas inlet thermistor error	23
E. 8 2. 2	Sub cool heat EX. gas outlet thermistor error□	24
E. 8 3. 1	Liquid pipe thermistor error	25
E. 8 4. 1	Current sensor error	26
E. 8 6. 1	Discharge pressure sensor error	27
E. 8 6. 3	Suction pressure sensor error	28
E. 8 6. 4	High pressure switch error	29
E. 9 4. 1	Over current error	30
E. 9 5. 1	Compressor control error	31
E. 9 7. 3	Outdoor unit fan motor error	32
E. 9 9. 1	4-way valve error	33
E. A 1. 1	Discharge temp. error	34
E. A 3. 1	Compressor temp. error	35
E. A 5. 1	Low pressure error	36
E. J 2. U	Branch box error	1,40 ~ 45

2-3-6 Error status for Branch Box Display

When an error occurs, an error description displays in the LED (No.401 - 405).

●	Lit
◎(n)	Flashing (number of flashing)
○	Unlit

Green	Red				Comment	Trouble shooting
	LED401	LED402	LED403	LED404		
●	●	●	●	●	Connected combination error	37
●	●	●	●	○	Power frequency error	38
●	●	●	○	●		39
Branch box identifying display	◎(1)	○	○	○	EEPROM access error	40
	◎(2)	○	○	○	Model information error	41
	◎(3)	○	○	○	Serial communication error between Outdoor Unit and branch box	1
					Serial communication error between branch boxes	1
	◎(4)	○	○	○	Serial communication error between branch boxes	1
Primary unit : ◎(1)	◎(5)	●	○	○	Serial communication error between Indoor Unit A and branch box	1
		○	●	○	Serial communication error between Indoor Unit B and branch box	1
		○	○	●	Serial communication error between Indoor Unit C and branch box	1
Secondary unit1 : ◎(2)	◎(6)	●	○	○	Indoor Unit A, liquid pipe thermistor error (CN309)	42
		○	●	○	Indoor Unit B, liquid pipe thermistor error (CN309)	
		○	○	●	Indoor Unit C, liquid pipe thermistor error (CN310)	
Secondary unit2 : ◎(3)	◎(7)	●	○	○	Indoor Unit A, gas pipe thermistor error (CN309)	43
		○	●	○	Indoor Unit B, gas pipe thermistor error (CN309)	
		○	○	●	Indoor Unit C, gas pipe thermistor error (CN310)	
◎(8)	○	○	○	●	Indoor Unit A, EEV control error (CN305)	44
					Indoor Unit B, EEV control error (CN306)	
					Indoor Unit C, EEV control error (CN307)	
◎(9)	○	○	○	○	Remote controller communication error	45

Error Indication Flashing Pattern

Example : "Serial communication error between Indoor Unit B and branch box" at Secondary unit1
 (LED401: 2times, LED402: 5times, LED403: Unlit, LED404: Lit, LED405: Unlit)

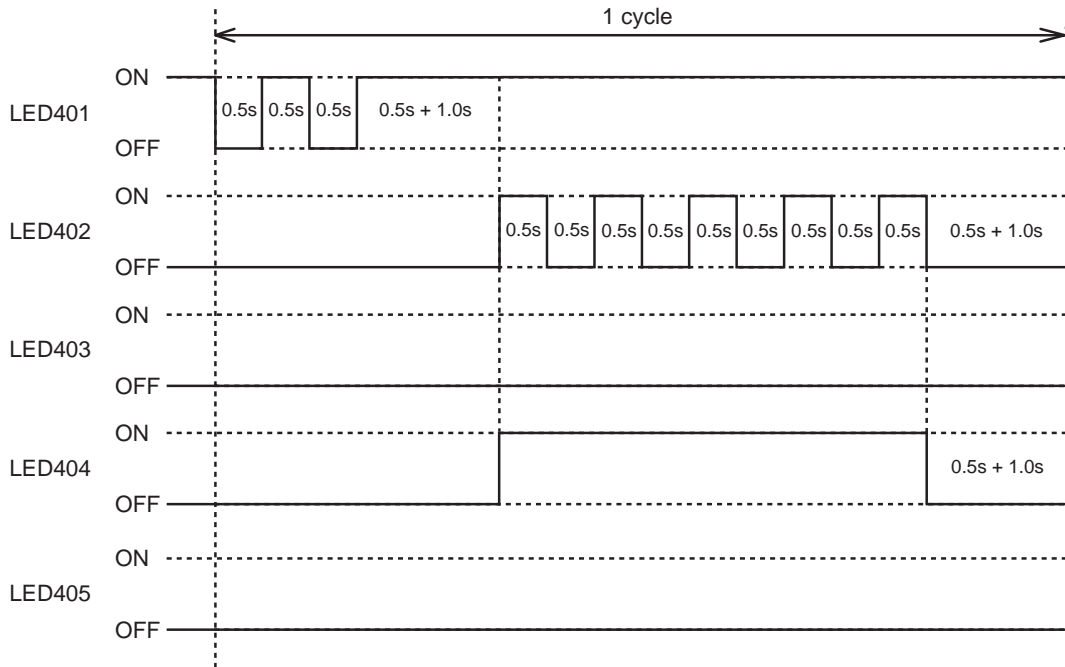

2-4 TROUBLE SHOOTING

<p>Trouble shooting 1 ALL UNIT Error Method: Serial Communication Error (Serial Forward / Reverse Transfer Error)</p>	<p>Indicate or Display: Outdoor Unit : Indoor Unit : Refer to Connection line and Serial signal error list Error Code : (Page 13)</p>
<p>Detective Actuators:</p> <p>Outdoor Unit Indoor Unit Branch Box (Primary / secondary)</p>	<p>Detective details:</p> <ul style="list-style-type: none"> • When the branch box cannot properly receive the serial signal from Outdoor unit / Indoor unit / Branch Box. • When the Outdoor unit / Indoor unit cannot properly receive the serial signal from Branch Box. <ul style="list-style-type: none"> - When power is turn-on : 2 minutes. - In operation : 15 seconds.

Forecast of Cause:

1. Connection failure
2. External cause
3. Main PCB(Outdoor unit) failure
4. Controller PCB(Indoor unit / Branch Box) failure

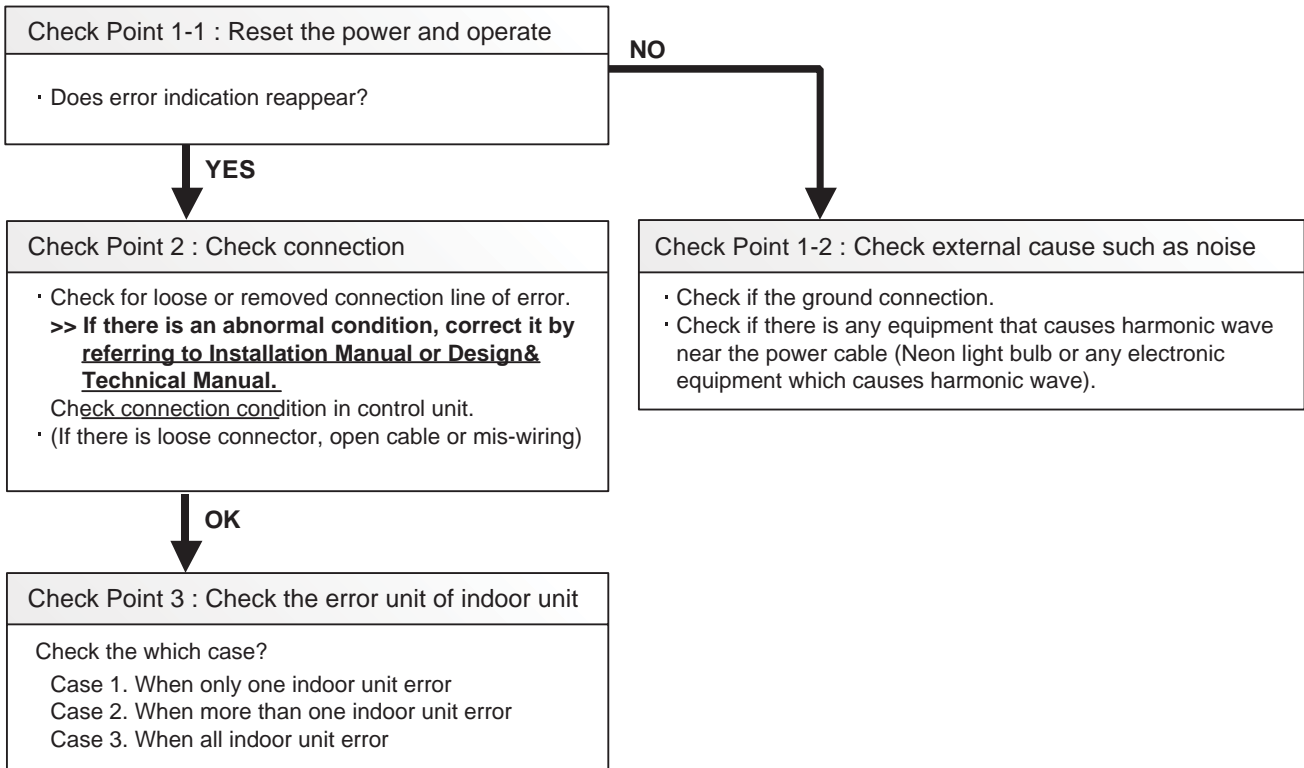

Case 1. When only one indoor unit error

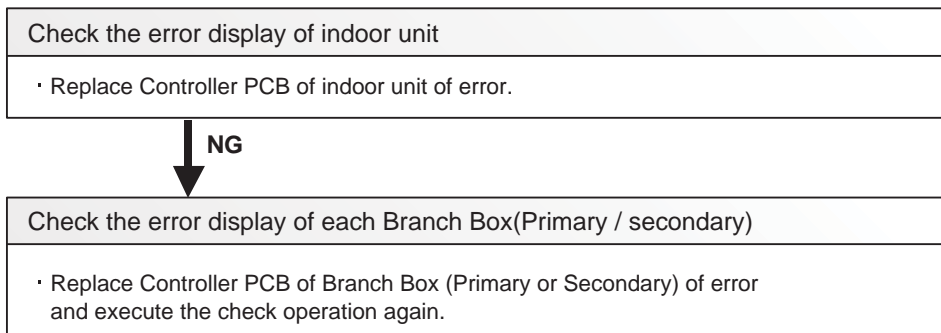

Case 2. When more than one indoor unit error (2unit or 3 unit)

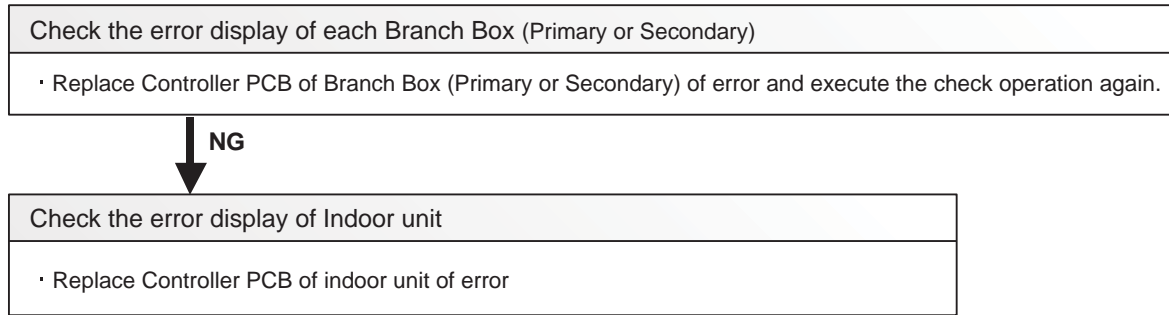

Case 3. When all indoor unit error

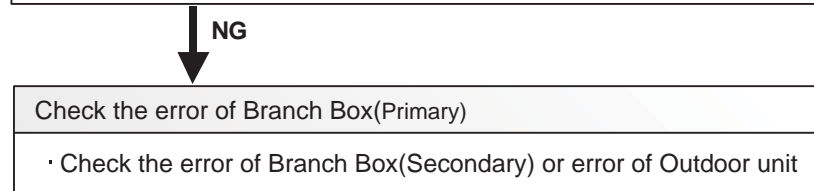
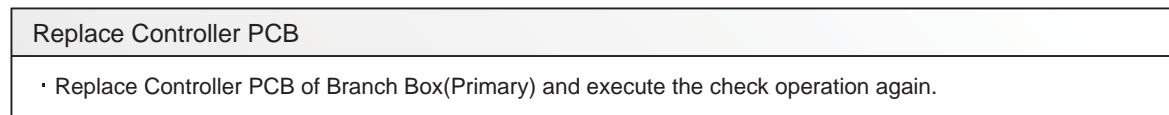

When Outdoor unit error

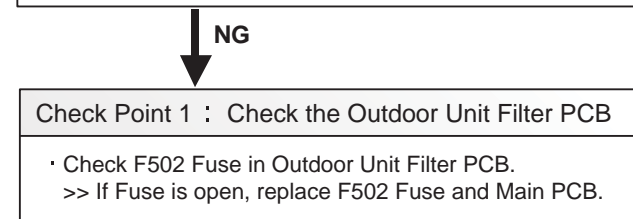
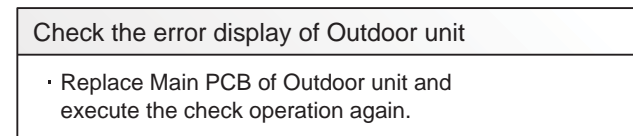

When Branch Box(Secondary) error

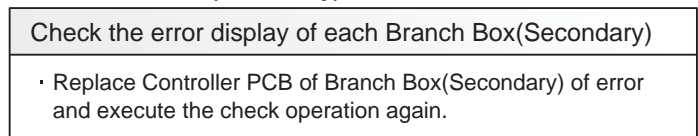

When there is no LED display of outdoor unit

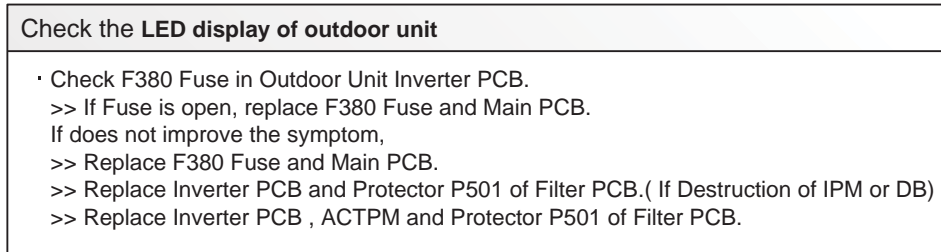

Connection Line (example)

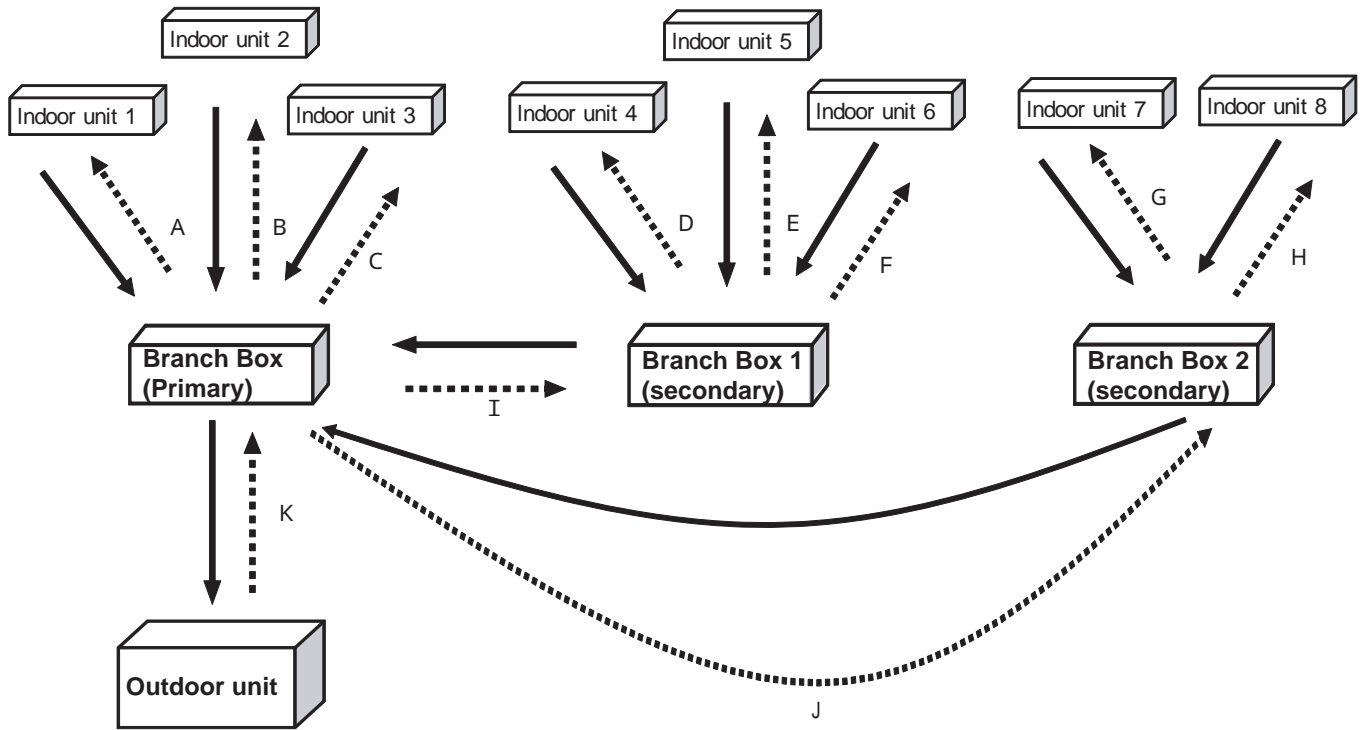

~ Serial Forward Transfer Error
 A ~ K Serial Reverse Transfer Error

Serial signal error list

	Indoor unit 1		Indoor unit 2		Indoor unit 3		Indoor unit 4		Indoor unit 5		Indoor unit 6		Indoor unit 7		Indoor unit 8		Branch Box(Primary)					Branch Box 1(secondary)					Branch Box 2(secondary)					Outdoor unit													
	1st	2nd	3rd	1st	2nd	3rd	1st	2nd	3rd	1st	2nd	3rd	1st	2nd	3rd	1st	2nd	3rd	LED401	LED402	LED403	LED404	LED405	LED401	LED402	LED403	LED404	LED405	LED401	LED402	LED403	LED404	LED405	LED961	LED962										
Serial Forward Transfer Error																			(1)	(5)															E	J	2	U							
																				(1)	(5)															E	J	2	U						
																				(1)	(5)																E	J	2	U					
																								(2)	(5)												E	J	2	U					
																								(2)	(5)												E	J	2	U					
																																						E	J	2	U				
																																							E	J	2	U			
																																								E	J	2	U		
																																								E	1	1	3		
																																							E	1	1	4			
Serial Reverse Transfer Error	A																																						E	5	U	1			
	B																																							E	5	U	1		
	C																																								E	5	U	1	
	D																																								E	5	U	1	
	E																																								E	5	U	1	
	F																																								E	5	U	1	
	G																																								E	5	U	1	
	H																																								E	5	U	1	
	I																																									E	J	2	U
	J																																									E	J	2	U
	K																																									E	1	1	3
																																									E	J	2	U	

LED Display pattern of Indoor unit
 • 1st - Operation LED • ○ Number of flashes (0.5sec)
 • 2nd - Timer LED • ⊙ Continuous flash
 • 3rd - Economy LED • - No display

LED Display pattern of Branch Box
 • (n) - Flashing(number of flashing)
 • - Lit
 • - Unlit

Trouble shooting 2 INDOOR UNIT Error Method: Wired Remote Controller Communication Error	Indicate or Display: Outdoor Unit : E.5 U.1 Indoor Unit : Operation LED 1 times Flash, Timer LED 2 Times Flash, Economy LED Continuous Flash. Error Code : 1 2
-------------------------------------------------------------------------------------------------------------------------------	---------------------------------------------------------------------------------------------------------------------------------------------------------------------------------------------------------------

Detective Actuators: Indoor unit controller PCB Wired Remote Controller	Detective details: Upon receiving the signal more than 1 time from Wired Remote or other Indoor unit, but the same signal has not been received more than 1 minute.
--------------------------------------------------------------------------------------	-------------------------------------------------------------------------------------------------------------------------------------------------------------------------------

Forecast of Cause : 1. Terminal connection abnormal 2. Wired Remote Controller failure 3. Controller PCB failure

Check Point 1 : Check the connection of terminal

After turning off the power, check & correct the followings.

- Indoor Unit - Check the connection of terminal between remote controller and Indoor unit, and check if there is a disconnection or short of the cable.



Check Point 2 : Check Remote controller and Controller PCB

- Check terminal voltage of controller PCB Connector. (Power supply for Remote)
 Cassette / Duct Type ⇒ CN14 , Wall mount Type ⇒ CN6 , Small size Wall mount Type ⇒ CN305(UTY-XCBXZ14)
 If DC12V, Remote Controller failure (Controller PCB is OK) >>> Replace Remote Controller
 If DC0V, Controller PCB failure (Remote is OK) >>> Replace Controller PCB and execute the check operation again.

▶ **In case of re-installation is done due to removed connector or incorrect wiring, turn on the power again.**



Trouble shooting 3 <u>INDOOR UNIT Error Method:</u> Check run unfinished	<u>Indicate or Display:</u> Outdoor Unit : E. 15. 6 Indoor Unit : Operation LED 1 times Flash, Timer LED 5 Times Flash, Economy LED Continuous Flash. Error Code : 15
-----------------------------------------------------------------------------------------------------	----------------------------------------------------------------------------------------------------------------------------------------------------------------------------------------------------------------------

<u>Detective Actuators:</u> Outdoor unit Branch BOX	<u>Detective details:</u> When the operation command is input by remote controller without check operation completion.
------------------------------------------------------------------	----------------------------------------------------------------------------------------------------------------------------------

<u>Forecast of Cause :</u> 1. Check operation not complete 2. Outdoor Main PCB changed 3. Branch BOX PCB changed

Check Point 1 : Check the indoor unit number connection
<ul style="list-style-type: none"> · Check the number of indoor unit connected. >> <u>If the check operation not complete, execute it by referring to Installation Manual or Design & Technical Manual.</u> >> <u>Upon correcting incorrect setting, reset the power.</u>



Check Point 2 : Replace Main PCB
<ul style="list-style-type: none"> · <u>Replace Main PCB, and execute the check operation again.</u>

<u>INDOOR UNIT Error Method:</u> Number of Wires and Pipes Error	<u>Indicate or Display:</u> Outdoor Unit : E.2 1.2 Indoor Unit : Operation LED 2 times Flash, Timer LED 1 Times Flash, Economy LED Continuous Flash. Error Code : 2 1
-----------------------------------------------------------------------------------	----------------------------------------------------------------------------------------------------------------------------------------------------------------------------------------------------------------------

<u>Detective Actuators:</u> Indoor unit	<u>Detective details:</u> When the operation command is input by remote controller without check operation completion. When a PCB has been replaced.
---------------------------------------------------	-------------------------------------------------------------------------------------------------------------------------------------------------------------------

<u>Forecast of Cause :</u> 1. Check operation not complete 2. Indoor Controller PCB changed 3. Branch BOX PCB changed

Check Point 1 : Check the indoor unit number connection
<ul style="list-style-type: none"> · Check the number of indoor unit connected. >> <u>If the check operation not complete, execute it by referring to Installation Manual or Design & Technical Manual.</u> >> <u>Upon correcting incorrect setting, reset the power.</u>



Check Point 2 : Replace Controller PCB
<ul style="list-style-type: none"> · <u>Replace Controller PCB, and execute the check operation again.</u>

Trouble shooting 4 INDOOR UNIT Error Method: Indoor Unit Capacity Error	Indicate or Display: Outdoor Unit : E. 22. 1 Indoor Unit : Operation LED 2 times Flash, Timer LED 2 Times Flash, Economy LED Continuous Flash. Error Code : 22
----------------------------------------------------------------------------------------------------	-----------------------------------------------------------------------------------------------------------------------------------------------------------------------------------------------------

Detective Actuators: All indoor unit	Detective details: When the total capacity of indoor units is outside of range between 38,000BTU and 63,000BTU.
----------------------------------------------------	-------------------------------------------------------------------------------------------------------------------------------

Forecast of Cause : 1. The selection of indoor units is incorrect 2. Main PCB(Outdoor unit) failure

Check Point 1 : Check the total capacity of indoor unit
· Check the total capacity of the connected indoor units. >> If abnormal condition is found, correct it by referring to Installation Manual or Design & Technical Manual.



Check Point 2 : Replace Main PCB
▶ If Check Point 1 do not improve the symptom, replace Main PCB(Outdoor unit), and execute the check operation again.

<p>Trouble shooting 5 <u>INDOOR UNIT Error Method:</u> Connected Combination Error</p>	<p>Indicate or Display: Outdoor Unit : E.5 U.1 or E.J 2.U Indoor Unit : Operation LED 2 times Flash, Timer LED 3 Times Flash, Economy LED Continuous Flash. Error Code : 2 3</p>
-----------------------------------------------------------------------------------------------------------------------	-----------------------------------------------------------------------------------------------------------------------------------------------------------------------------------------------------------------------------

<p><u>Detective Actuators:</u></p> <p>Indoor Unit Branch Box</p>	<p><u>Detective details:</u></p> <p>When power is on and one of the below occurs.</p> <ol style="list-style-type: none"> 1. When the wirring is mistake 2. When the connection outdoor unit different. 3. When the connection indoor unit of unsupported multi.
------------------------------------------------------------------------------	---------------------------------------------------------------------------------------------------------------------------------------------------------------------------------------------------------------------------------------------------------------------------------------------------------

<p><u>Forecast of Cause:</u></p> <ol style="list-style-type: none"> 1. connections condition in Controller PCB(Indoor unit / Branch Box)

<p>Check Point 1 : Check the Indoor unit / Branch Box</p>
<p><input type="checkbox"/> Check the Indoor unit / Branch Box</p> <p>>> <u>If there is abnormal connect, correct it by referring to Installation Manual or Design & Technical Manual.</u></p> <p>>> <u>Upon correcting incorrect setting, and execute the check operation again.</u></p>

<p>Trouble shooting 6 <u>INDOOR UNIT Error Method:</u> Number of Indoor Units Error</p>	<p><u>Indicate or Display:</u> Outdoor Unit : E. 24. 2 Indoor Unit : Operation LED 2 times Flash, Timer LED 4 Times Flash, Economy LED Continuous Flash. Error Code : 24</p>
------------------------------------------------------------------------------------------------------------------------	-------------------------------------------------------------------------------------------------------------------------------------------------------------------------------------------------------------------------------------

<p><u>Detective Actuators:</u> Indoor Unit</p>	<p><u>Detective details:</u> When the total connection number of indoor units is outside of range between 2 and 8.</p>
------------------------------------------------------------------	------------------------------------------------------------------------------------------------------------------------------------------

<p><u>Forecast of Cause :</u> 1. Indoor unit connection failure</p>

<p>Check Point 1 : Check the indoor unit number connection</p>
<ul style="list-style-type: none"> · Check the indoor unit number connection. >> <u>If there is an abnormal condition, correct it by referring to Installation Manual or Design & Technical Manual.</u> >> <u>Upon correcting incorrect setting, reset the power.</u>

<p>Trouble shooting 7 <u>Branch Box Error Method:</u> Number of Branch Boxes Error</p>	<p><u>Indicate or Display:</u> Outdoor Unit : E. 24. 3 Indoor Unit : Operation LED 2 times Flash, Timer LED 4 Times Flash, Economy LED Continuous Flash. Error Code : 24</p>
-----------------------------------------------------------------------------------------------------------------------	-------------------------------------------------------------------------------------------------------------------------------------------------------------------------------------------------------------------------

<p><u>Detective Actuators:</u> Branch Box</p>	<p><u>Detective details:</u> When the number of branch boxes ① and ② are different, and the operation command is input to the outdoor unit.</p> <p>① Memorized number at the check operation. ② Number of Serial forward signal.</p>
-----------------------------------------------------------------	-------------------------------------------------------------------------------------------------------------------------------------------------------------------------------------------------------------------------------------------------------

<p><u>Forecast of Cause :</u></p> <ol style="list-style-type: none"> 1. Branch box power failure 2. Branch box connection failure

<p>Check Point 1 : Check the Branch box power</p>
<ul style="list-style-type: none"> · Check the Branch Box power >> <u>If there is an abnormal condition, power turned on.</u>



<p>Check Point 2 : Check the Branch box connection</p>
<ul style="list-style-type: none"> · Check the Branch Box connection. >> <u>If there is an abnormal condition, correct it by referring to Installation Manual or Design & Technical Manual.</u> >> <u>Upon correcting incorrect setting, reset the power.</u>

Trouble shooting 8 INDOOR UNIT Error Method: Indoor Unit Model Information Error EEPROM Access Abnormal	Indicate or Display: Outdoor Unit : E.5 U.1 Indoor Unit : Operation LED 3 times Flash, Timer LED 2 Times Flash, Economy LED Continuous Flash. Error Code : 3 2
----------------------------------------------------------------------------------------------------------------------------------------------	---------------------------------------------------------------------------------------------------------------------------------------------------------------------------------------------------------------

Detective Actuators: Indoor Unit	Detective details: 3 continuous failure of read test of EEPROM at power on, or apparent model information error from EEPROM. Also, error on model information upon model information test of EEPROM, or Model information of EEPROM not possible to recover.
------------------------------------------------	------------------------------------------------------------------------------------------------------------------------------------------------------------------------------------------------------------------------------------------------------------------------

Forecast of Cause : 1. External cause 2. connections condition in Controller PCB 3. Controller PCB failure

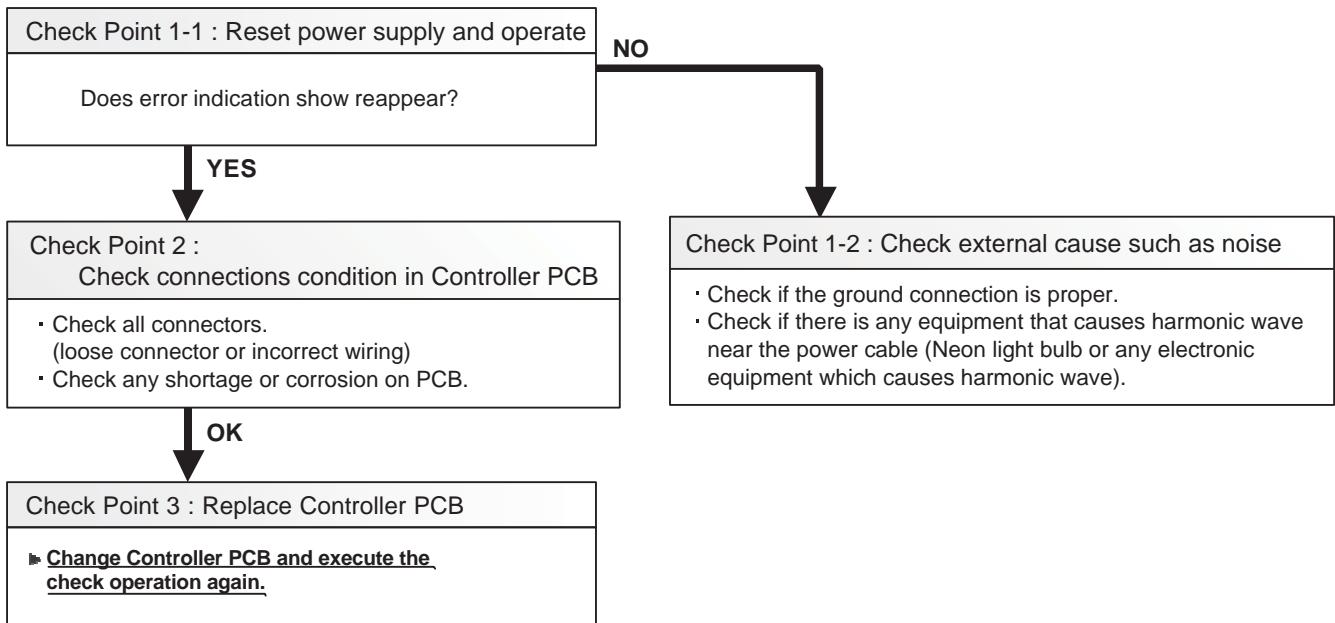

<p>Trouble shooting 9 <u>INDOOR UNIT Error Method:</u> Manual Auto Switch Error</p>	<p><u>Indicate or Display:</u> Outdoor Unit : No Display Indoor Unit : Operation LED 3 times Flash, Timer LED 2 Times Flash, Economy LED Continuous Flash. Error Code : 3 5</p>
--------------------------------------------------------------------------------------------------------------------	------------------------------------------------------------------------------------------------------------------------------------------------------------------------------------------------------------

<p><u>Detective Actuators:</u> Indoor Unit Controller PCB Indicator PCB Manual Auto Switch</p>	<p><u>Detective details:</u> When the Manual Auto Switch becomes ON for consecutive 30 or more seconds.</p>
----------------------------------------------------------------------------------------------------------------------	-------------------------------------------------------------------------------------------------------------------------

Forecast of Cause :
1. Manual Auto Switch failure 2. Controller PCB and Indicator PCB failure

<p>Check Point 1 : Check the Manual Auto Switch</p>	
<ul style="list-style-type: none"> · Check if Manual Auto Switch is kept pressed. · Check ON/OFF switching operation by using a meter. >> <u>If Manual Auto Switch is disabled (on/off switching), replace it.</u> 	



<p>Check Point 2 : Replace Controller PCB and Indicator PCB</p>
<p>▶ <u>If Check Point 1 do not improve the symptom, replace Controller PCB and Indicator PCB and execute the check operation again.</u></p>

Trouble shooting 10 INDOOR UNIT Error Method: Indoor Room Thermistor Error	Indicate or Display: Outdoor Unit : E.5 U.1 Indoor Unit : Operation LED 4 times Flash, Timer LED 1 Times Flash, Economy LED Continuous Flash. Error Code : 4 1
-------------------------------------------------------------------------------------------------------	-----------------------------------------------------------------------------------------------------------------------------------------------------------------------------------------------------

Detective Actuators: Indoor Unit Controller PCB Circuit Indoor Temperature Thermistor	Detective details: Indoor unit thermistor is open or short is detected always.
----------------------------------------------------------------------------------------------------	------------------------------------------------------------------------------------------

Forecast of Cause : 1. Connector failure connection 2. Thermistor failure 3. Controller PCB failuer

Check Point 1 : Check connection of Connector

- Check if connector is loose or removed
- Check erroneous connection
- Check if thermistor cable is open

>>Reset Power when reinstalling due to removed connector or incorrect wiring.



Check Point 2 : Remove connector and check Thermistor resistance value

Thermistor Characteristics (Rough value)

Temperature (°F)	32	41	50	59	68	77	86	95
Resistance Value (kΩ)	33.6	25.2	20.1	15.8	12.5	10.0	8.0	6.5

Temperature (°F)	104	113	122
Resistance Value (kΩ)	5.3	4.3	3.5

▶ **If Thermistor is either open or shorted, replace it and reset the power.**



Check Point 3 : Check voltage of Controller PCB (DC5.0V)

Make sure circuit diagram of each indoor unit and check terminal voltage at Thermistor (DC5.0V)

- Duct circuit diagram (Connector connection)
- Small size Wall mount circuit diagram(Connector connection)
- Cassette circuit diagram (Connector connection)
- Wall mount Scircuit diagram (Direct soldering to PCB)

Duct circuit diagram (Connector connection)

Small size Wall mount circuit diagram(Connector connection)

Cassette circuit diagram (Connector connection)

Wall mount Scircuit diagram (Direct soldering to PCB)

▶ **If the voltage does not appear, replace Controller PCB and execute the check operation again.**

Trouble shooting 11 INDOOR UNIT Error Method: Indoor Heat Ex. Thermistor Error	Indicate or Display: Outdoor Unit : E.5 U.1 Indoor Unit : Operation LED 4 times Flash, Timer LED 2 Times Flash, Economy LED Continuous Flash. Error Code : 4 2
-----------------------------------------------------------------------------------------------------------	-----------------------------------------------------------------------------------------------------------------------------------------------------------------------------------------------------

Detective Actuators: Indoor Unit Controller PCB Heat Exchanger (MID) Thermistor	Detective details: Indoor unit thermistor is open or short is detected always.
----------------------------------------------------------------------------------------------	------------------------------------------------------------------------------------------

Forecast of Cause : 1. Connector failure connection 2. Thermistor failure 3. Controller PCB failuer

Check Point 1 : Check connection of Connector

- Check if connector is loose or removed
- Check erroneous connection
- Check if thermistor cable is open

>>Reset Power when reinstalling due to removed connector or incorrect wiring.



Check Point 2 : Remove connector and check Thermistor resistance value

Thermistor Characteristics (Rough value)

Temperature (°F)	32	41	50	59	68	77	86	95
Resistance Value (kΩ)	168.6	129.8	100.9	79.1	62.5	49.8	40.0	32.4

Temperature (°F)	104	113	122
Resistance Value (kΩ)	26.3	21.2	17.8

► **If Thermistor is either open or shorted, replace it and reset the power.**



Check Point 3 : Check voltage of Controller PCB (DC5.0V)

Make sure circuit diagram of each indoor unit and check terminal voltage at Thermistor (DC5.0V)

• Duct circuit diagram (Connector connection)

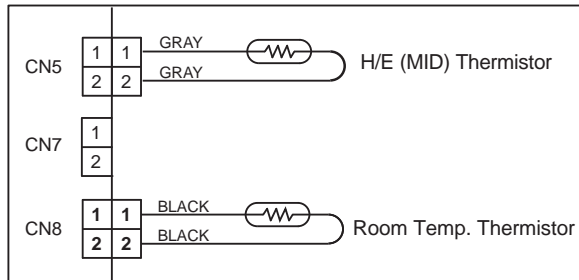

• Small size Wall mount circuit diagram(Connector connection)

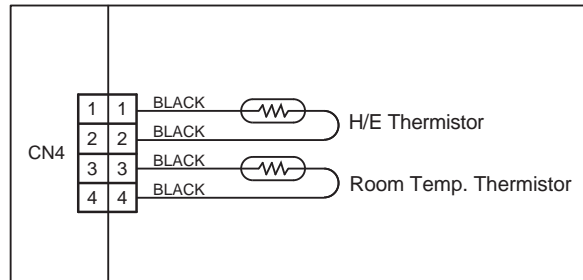

• Cassette circuit diagram (Connector connection)

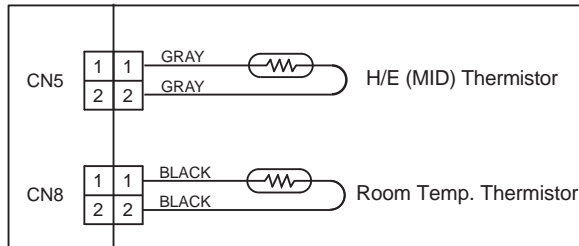

• Wall mount circuit diagram (Direct soldering to PCB)

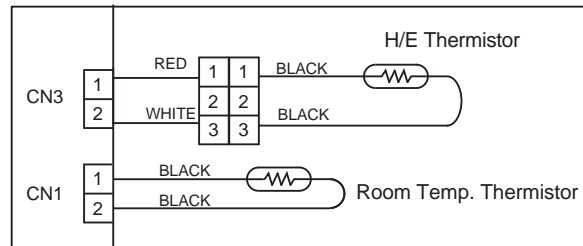

► **If the voltage does not appear, replace Controller PCB and execute the check operation again.**

Trouble shooting 12 INDOOR UNIT Error Method: Indoor Unit Fan Motor Error	Indicate or Display: Outdoor Unit : E.5 U.1 Indoor Unit : Operation LED 5 times Flash, Timer LED 1 Times Flash, Economy LED Continuous Flash. Error Code : 5 1
------------------------------------------------------------------------------------------------------	-----------------------------------------------------------------------------------------------------------------------------------------------------------------------------------------------------

Detective Actuators: Indoor Unit Controller PCB Indoor Fan Motor	Detective details: When Indoor fan control is either phase control or DC control and rotation feed back control is ON, the feed back rotation value becomes 0 and lasts for more than 1 minute at motor operation condition. Or, the feed back rotation value continues at 1/3 of target value for more than 1 minute.
-------------------------------------------------------------------------------	----------------------------------------------------------------------------------------------------------------------------------------------------------------------------------------------------------------------------------------------------------------------------------------------------------------------------------

Forecast of Cause : 1. Fan MOTOR failure 2. Fan motor winding open 3. Motor protection by surrounding temp. increase
4. Controller PCB failure

Check Point 1 : Check rotation of Fan

Rotate the fan by hand when operation is off.
(Check if fan is caught, dropped off or locked motor)
>>If Fan or Bearing is abnormal, replace it.



Check Point 2 : Check Motor winding

Check Indoor Fan motor
>>If Fan motor is abnormal, replace it.



Check Point 3 : Check ambient temp. around motor

Check excessively high temperature around the motor.
(If there is any surrounding equipment that causes heat)
>>Upon the temperature coming down, restart operation.



Check Point 4 : Replace Controller PCB

Change Controller PCB and execute the check operation again.

Trouble shooting 13 INDOOR UNIT Error Method: Drainage Error	Indicate or Display: Outdoor Unit : E.5 U.1 Indoor Unit : Operation LED 5 times Flash, Timer LED 3 Times Flash, Economy LED Continuous Flash. Error Code : 53
-----------------------------------------------------------------------------------------	----------------------------------------------------------------------------------------------------------------------------------------------------------------------------------------------------

Detective Actuators: Indoor Unit Controller PCB Circuit Float Switch	Detective details: When Float switch is ON for more than 3 minutes.
-----------------------------------------------------------------------------------	-------------------------------------------------------------------------------

Forecast of Cause : 1. Float switch failure 2. Shorted connector/wire 3. Controller PCB failure
 4. Drain pump failure 5. Hose clogging

Check Point 1 : Check Float Switch

- Check operation of float switch. (any blocking by dust, etc.)
- Remove Float switch and check ON/OFF switching operation by using a meter.
>>If Float switch is abnormal, replace it.

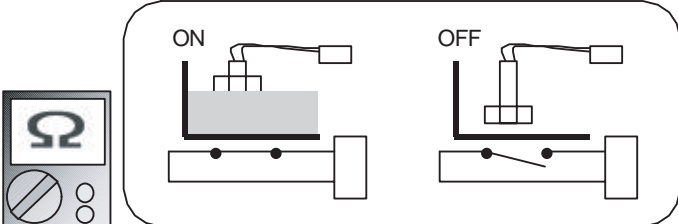

OK

Check Point 2 : Check Connector (CN 9) / Wire

- Check loose contact of CN9 /shorted wire (pinched wire).
>>Replace Float switch if the wire is abnormal

OK

Check Point 3 : Check Drain Hose

- Check Drain Hose .
>>If there is Hose clogging. Please clear the clog.

OK

Check Point 4 : Check Controller PCB

If Check Point 1 ~ 3 do not improve the symptom, change Controller PCB and execute the check operation again.

Attention!!
 Wall mount / Small size wall mount type does not have a float switch.
 In this case, replace Controller PCB and set up the original address.
 Please refer to.

Trouble shooting 14 OUTDOOR UNIT Error Method: Outdoor Unit Model Information Error	Indicate or Display: Outdoor Unit : E. 62. 1 Indoor Unit : Operation LED 6 times Flash, Timer LED 2 Times Flash, Economy LED Continuous Flash. Error Code : 62
----------------------------------------------------------------------------------------------------------------	-----------------------------------------------------------------------------------------------------------------------------------------------------------------------------------------------------

Detective Actuators: Outdoor unit Main PCB	Detective details: • Access to EEPROM failed due to some cause after outdoor unit started.
------------------------------------------------------	------------------------------------------------------------------------------------------------------

Forecast of Cause : 1. External cause (Noise, temporary open, voltage drop) 2. Main PCB failure

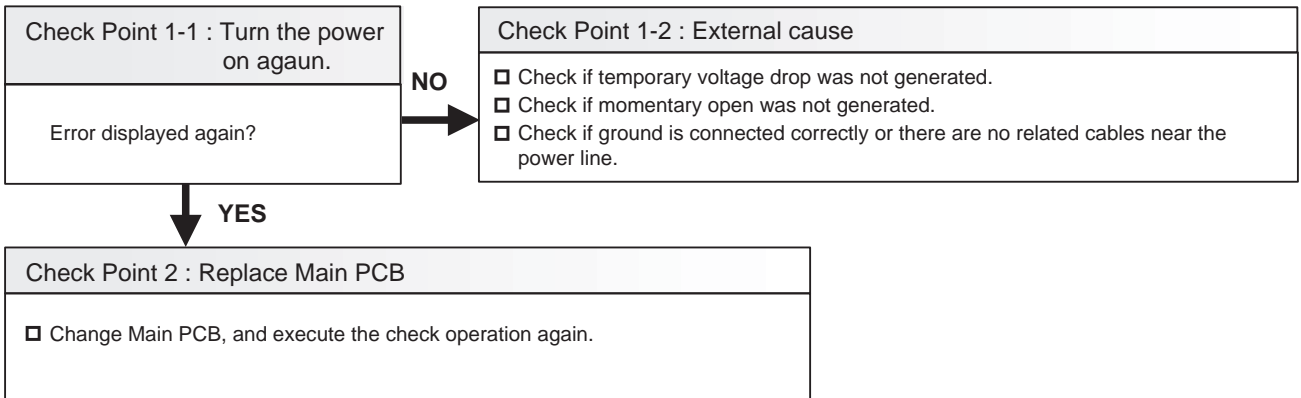

Trouble shooting 15 OUTDOOR UNIT Error Method: Inverter Error	Indicate or Display: Outdoor Unit : E. 63. 1 Indoor Unit : Operation LED 6 times Flash, Timer LED 3 Times Flash, Economy LED Continuous Flash. Error Code : 63
------------------------------------------------------------------------------------------	-----------------------------------------------------------------------------------------------------------------------------------------------------------------------------------------------------

Detective Actuators: Inverter PCB Main PCB Filter PCB	Detective details: • Error information received from Inverter PCB
-----------------------------------------------------------------------	-----------------------------------------------------------------------------

Forecast of Cause :	<ol style="list-style-type: none"> 1. External cause 2. Power supply line & Communication line to Filter PCB to Inverter PCB wiring disconnection, open 3. Inverter PCB failure 4. Main PCB failure 5. Filter PCB failure
----------------------------	----------------------------------------------------------------------------------------------------------------------------------------------------------------------------------------------------------------------------------------------------------------------------------

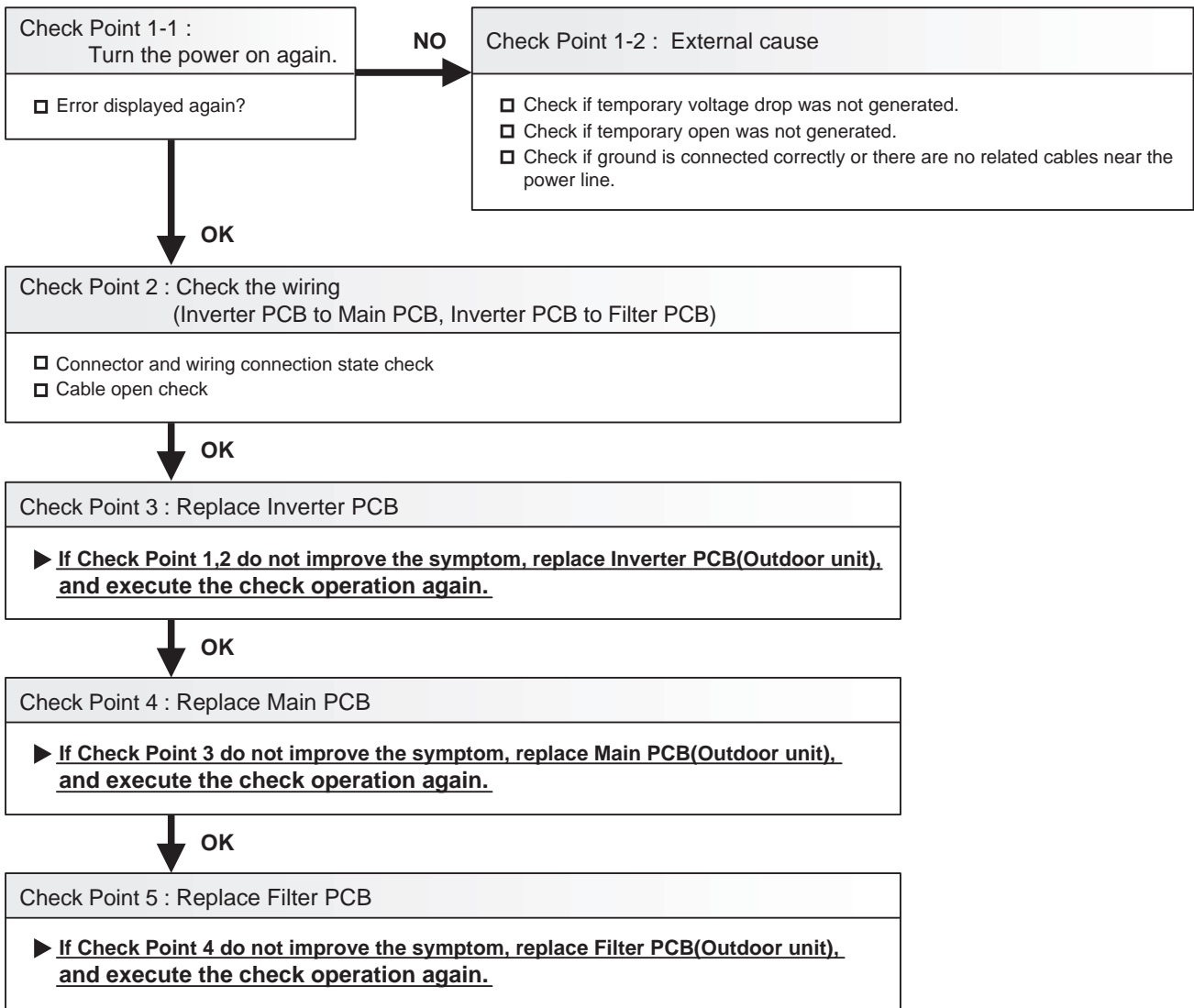

Trouble shooting 16 <u>OUTDOOR UNIT Error Method:</u> A.F Voltage Error	<u>Indicate or Display:</u> Outdoor Unit : E. 64. 1 Indoor Unit : Operation LED 6 times Flash, Timer LED 4 Times Flash Economy LED Continuous Flash. Error Code : 64
----------------------------------------------------------------------------------------------------	---------------------------------------------------------------------------------------------------------------------------------------------------------------------------------------------------------------------

<u>Detective Actuators:</u> Outdoor Unit Main PCB Outdoor Unit ACTPM PCB	<u>Detective details:</u> <ul style="list-style-type: none"> • Inverter low voltage protection • Inverter overvoltage protection
---------------------------------------------------------------------------------------	--------------------------------------------------------------------------------------------------------------------------------------------------------------------

Forecast of Cause :
 1. Connector connection failure 2. Inverter PCB failure 3. ACTPM failure

Check Point 1 : Check connections condition in control unit

- Check if the terminal connection is loose.
- Check if connector is removed.
- Check if connector is erroneous connection.
- Check if cable is open.

>> Upon correcting the removed connector or mis-wiring, reset the power.



Check Point 2 : Check ACTPM

- Check ACTPM (**PARTS INFORMATION 8**).

▶ If ACTPM is abnormal, replace it.



Check Point 3 : Replace Inverter PCB

▶ If Check Point 1,2 do not improve the symptom, replace Inverter PCB, and execute the check operation again.

Trouble shooting 17 OUTDOOR UNIT Error Method: Discharge Thermistor Error	Indicate or Display: Outdoor Unit : E. 71. 1 Indoor Unit : Operation LED 7 times Flash, Timer LED Times Flash, Economy LED Continuous Flash. Error Code : 71
------------------------------------------------------------------------------------------------------	---------------------------------------------------------------------------------------------------------------------------------------------------------------------------------------------------

Detective Actuators: Discharge temperature thermistor	Detective details: <ul style="list-style-type: none"> • Discharge temperature thermistor short detected • Discharge thermistor open detected
---------------------------------------------------------------------	--------------------------------------------------------------------------------------------------------------------------------------------------------------------------------

Forecast of Cause :

1. Connector connection failure, open
2. Thermistor failure
3. Main PCB failure

Check Point 1 : Check the connector connection and cable open

- Connector connection state check
- Cable open check

↓ OK

Check Point 2 : Check the thermistor

- Thermistor characteristics check (Disconnect the thermistor from the PCB and check.)
 * For the thermistor characteristics, refer to the "Service Parts Information 5".

↓ OK

Check Point 3 : Check voltage of Main PCB (DC5.0V)

- Main PCB (CN62:1-2) voltage value = 5V
 Remove the thermistor from Main PCB, check the voltage.

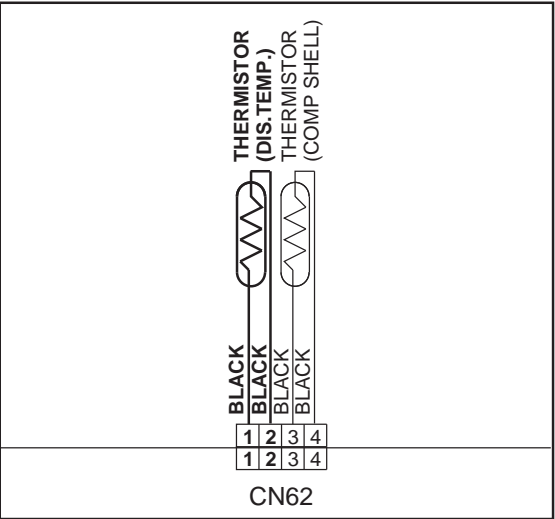

Discharge temperature thermistor (CN62:1-2)

► **If the voltage does not appear, replace Main PCB, and execute the check operation again.**

Trouble shooting 18
OUTDOOR UNIT Error Method:
Compressor Thermistor Error

Indicate or Display:
Outdoor Unit : E. 72. 1
Indoor Unit : Operation LED 7 times Flash, Timer LED 2 Times Flash, Economy LED Continuous Flash.
Error Code : 72

Detective Actuators:

Compressor temperature thermistor

Detective details:

- Compressor temperature thermistor short detected
- Compressor thermistor open detected

- Forecast of Cause :**
1. Connector connection failure, open
 2. Thermistor failure
 3. Main PCB failure

Check Point 1 : Check the connector connection and cable open

- Connector connection state check
- Cable open check

OK

Check Point 2 : Check the thermistor

- Thermistor characteristics check (Disconnect the thermistor from the PCB and check.)
 * For the thermistor characteristics, refer to the "Service Parts Information 14".

OK

Check Point 3 : Check voltage of Main PCB (DC5.0V)

- Main PCB (CN62:3-4) voltage value = 5V
 Remove the thermistor from Main PCB, check the voltage.

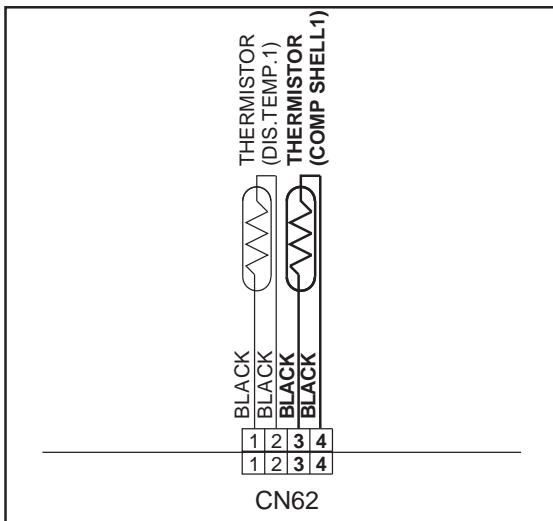

Compressor temperature thermistor (CN62:3-4)

► **If the voltage does not appear, replace Main PCB, and execute the check operation again.**

Trouble shooting 19 OUTDOOR UNIT Error Method: Heat Ex. Liquid Outlet Temp. Thermistor Error	Indicate or Display: Outdoor Unit : E. 73. 3 Indoor Unit : Operation LED 7 times Flash, Timer LED 3 Times Flash, Economy LED Continuous Flash. Error Code : 73
-----------------------------------------------------------------------------------------------------------------------------------	---------------------------------------------------------------------------------------------------------------------------------------------------------------------------------------------------------------

Detective Actuators: Heat exchanger liquid temperature thermistor	Detective details: • Heat exchanger outlet temperature thermistor short or open detected
---------------------------------------------------------------------------------	--------------------------------------------------------------------------------------------------------

Forecast of Cause :

1. Connector connection defective, open
2. Thermistor failure
3. Main PCB failure

Check Point 1 : Check the connector connection and cable open

- Connector connection state check
- Cable open check



Check Point 2 : Check the thermistor

- Thermistor characteristics check (Disconnect the thermistor from the PCB and check.)
 * For the thermistor characteristics, refer to the "Service Parts Information 5".



Check Point 3 : Check voltage of Main PCB (DC5.0V)

- Main PCB (CN63:1-2) voltage value = 5V
Remove the thermistor from Main PCB, check the voltage.

Heat exchanger outlet temperature thermistor (CN63:1-2)

► **If the voltage does not appear, replace Main PCB, and execute the check operation again.**

Trouble shooting 20
OUTDOOR UNIT Error Method:
Outdoor Thermistor Error

Indicate or Display:
Outdoor Unit : E. 74. 1
Indoor Unit : Operation LED 7 times Flash, Timer LED 4 Times Flash, Economy LED Continuous Flash.
Error Code : 74

Detective Actuators:

Outdoor temperature thermistor

Detective details:

- Outdoor temperature thermistor short or open detected

- Forecast of Cause :**
1. Connector connection defective, open
 2. Thermistor failure
 3. Main PCB failure

Check Point 1 : Check the connector connection and cable open

- Connector connection state check
- Cable open check

↓ OK

Check Point 2: Check the thermistor

- Thermistor characteristics check (Disconnect the thermistor from the PCB and check.)
 * For the thermistor characteristics, refer to the "Service Parts Information 5".

↓ OK

Check Point 3 : Check voltage of Main PCB (DC5.0V)

- Main PCB (CN61:1-3) voltage value = 5V
 Remove the thermistor from Main PCB, check the voltage.

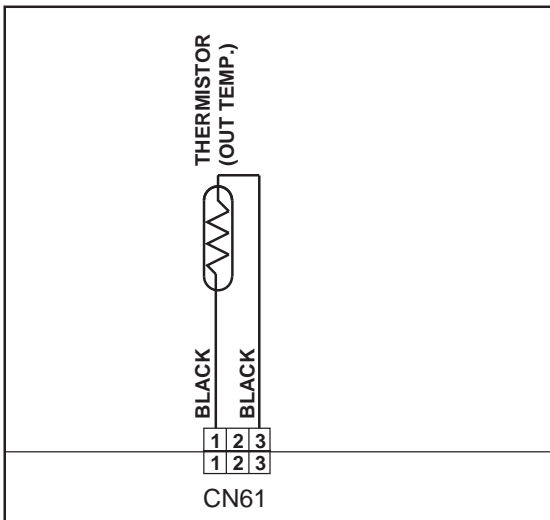

Outdoor temperature thermistor (CN61:1-3)

► **If the voltage does not appear, replace Main PCB, and execute the check operation again.**

Trouble shooting 21 OUTDOOR UNIT Error Method: Suction Gas Thermistor Error	Indicate or Display: Outdoor Unit : E. 75. 1 Indoor Unit : Operation LED 7 times Flash, Timer LED 5 Times Flash, Economy LED Continuous Flash. Error Code : 75
--------------------------------------------------------------------------------------------------------	-----------------------------------------------------------------------------------------------------------------------------------------------------------------------------------------------------

Detective Actuators: Suction gas temperature thermistor	Detective details: • Suction gas temperature thermistor short or open detected
-----------------------------------------------------------------------	----------------------------------------------------------------------------------------------

Forecast of Cause : 1. Connector connection defective, open
2. Thermistor failure
3. Main PCB failure

Check Point 1 : Check the connector connection and cable open

Connector connection state check
 Cable open check



Check Point 2 : Check the thermistor

Thermistor characteristics check (Disconnect the thermistor from the PCB and check.)
* For the thermistor characteristics, refer to the "Service Parts Information 5".



Check Point 3 : Check voltage of Main PCB (DC5.0V)



Main PCB (CN66:1-3) voltage value = 5V
Remove the thermistor from Main PCB, check the voltage.

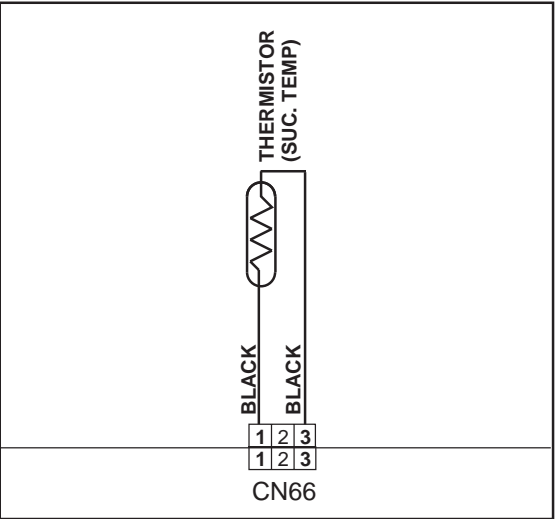

Suction gas temperature thermistor (CN66:1-3)

► **If the voltage does not appear, replace Main PCB, and execute the check operation.**

Trouble shooting 22
OUTDOOR UNIT Error Method:
Heat Sink Thermistor Error

Indicate or Display:
Outdoor Unit : E. 77. 1
Indoor Unit : Operation LED 7 times Flash, Timer LED 7 Times Flash,
Economy LED Continuous Flash.
Error Code : 77

Detective Actuators:

Inverter PCB

Detective details:

- Heat sink temperature thermistor (Built-in IPM) open/short detected

Forecast of Cause : 1. Inverter PCB failure

▶ **If this error is displayed, replace Inverter PCB**

Trouble shooting 23 OUTDOOR UNIT Error Method: Sub-cool Heat EX. Gas Inlet Thermistor Error	Indicate or Display: Outdoor Unit : E. 82. 1 Indoor Unit : Operation LED 8 times Flash, Timer LED 2 Times Flash, Economy LED Continuous Flash. Error Code : 82
------------------------------------------------------------------------------------------------------------------------	-----------------------------------------------------------------------------------------------------------------------------------------------------------------------------------------------------

Detective Actuators: Sub-cooling heat exchanger gas inlet temperature thermistor	Detective details: • Sub-cooling heat exchanger gas inlet temperature thermistor short or open detected
------------------------------------------------------------------------------------------------	-----------------------------------------------------------------------------------------------------------------------

Forecast of Cause : 1. Connector connection defective, open
2. Thermistor failure
3. Main PCB failure

Check Point 1 : Check the connector connection and cable open

Connector connection state check
 Cable open check



Check Point 2 : Check the thermistor

Thermistor characteristics check (Disconnect the thermistor from the PCB and check.)
* For the thermistor characteristics, refer to the "Service Parts Information 5".



Check Point 3 : Check voltage of Main PCB (DC5.0V)

Main PCB (CN65:1-2) voltage value = 5V
Remove the thermistor from Main PCB, check the voltage.

Sub-cooling heat exchanger gas inlet thermistor (CN65:1-2)

► **If the voltage does not appear, replace Main PCB, and execute the check operation again.**

Trouble shooting 24 OUTDOOR UNIT Error Method: Sub-cool Heat Ex. Gas Outlet Thermistor Error	Indicate or Display: Outdoor Unit : E. 82. 2 Indoor Unit : Operation LED 8 times Flash, Timer LED 2 Times Flash, Economy LED Continuous Flash. Error Code : 82
-------------------------------------------------------------------------------------------------------------------------	-----------------------------------------------------------------------------------------------------------------------------------------------------------------------------------------------------

Detective Actuators: Sub-cooling heat exchanger gas outlet temperature thermistor	Detective details: • Sub-cooling heat exchanger gas outlet temperature thermistor short or open detected
-------------------------------------------------------------------------------------------------	------------------------------------------------------------------------------------------------------------------------

Forecast of Cause :

1. Connector connection failur, open
2. Thermistor failure
3. Main PCB failure

Check Point 1 : Check the connector connection and cable open

- Connector connection state check
- Cable open check

↓ **OK**

Check Point 2 : Check the thermistor

- Thermistor characteristics check (Disconnect the thermistor from the PCB and check.)
* For the thermistor characteristics, refer to the "Service Parts Information 5".

↓ **OK**

Check Point 3 : Check voltage of Main PCB (DC5.0V)

DC

- Main PCB (CN63:4-5) voltage value = 5V
Remove the thermistor from Main PCB, check the voltage.

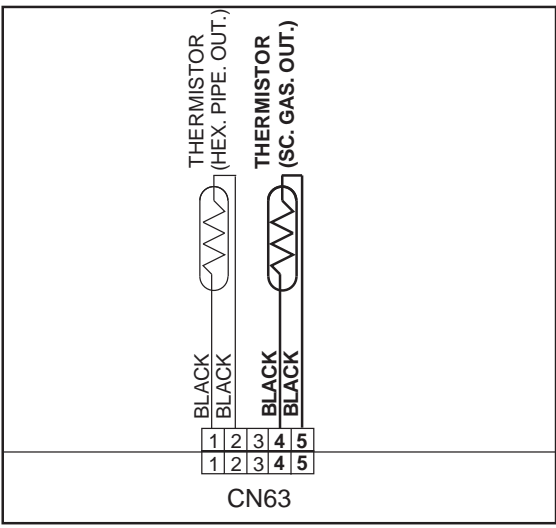

Heat exchanger liquid outlet thermistor (CN63:4-5)

▶ **If the voltage does not appear, replace Main PCB, and execute the check operation again.**

Trouble shooting 25 OUTDOOR UNIT Error Method: Liquid Pipe Thermistor Error	Indicate or Display: Outdoor Unit : E. 83. 1 Indoor Unit : Operation LED 8 times Flash, Timer LED 3 Times Flash, Economy LED Continuous Flash. Error Code : 83
--------------------------------------------------------------------------------------------------------	-----------------------------------------------------------------------------------------------------------------------------------------------------------------------------------------------------

Detective Actuators: Heat exchanger liquid outlet thermistor	Detective details: • Heat exchanger liquid pipe thermistor short or open detected
----------------------------------------------------------------------------	-------------------------------------------------------------------------------------------------

Forecast of Cause :

1. Connector connection failur, open
2. Thermistor failure
3. Main PCB failure

Check Point 1 : Check the connector connection and cable open

- Connector connection state check
- Cable open check

↓ OK

Check Point 2 : Check the thermistor

- Thermistor characteristics check (Disconnect the thermistor from the PCB and check.)
* For the thermistor characteristics, refer to the "Service Parts Information 5".

↓ OK

Check Point 3 : Check voltage of Main PCB (DC5.0V)

DC

- Main PCB (CN63:1-2) voltage value = 5V
Remove the thermistor from Main PCB, check the voltage.

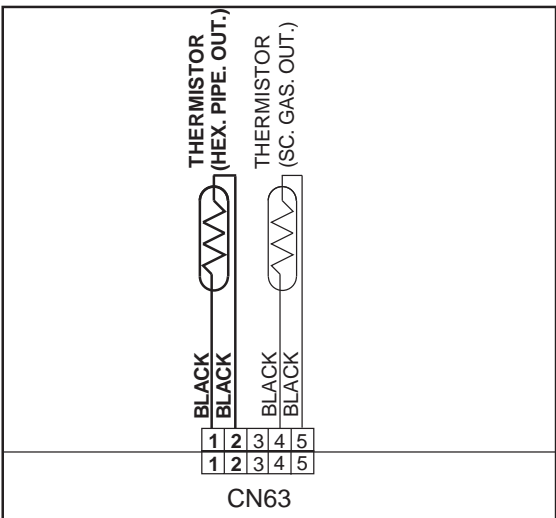

Heat exchanger liquid outlet thermistor (CN63:1-2)

► **If the voltage does not appear, replace Main PCB, and execute the check operation again.**

Trouble shooting 26
OUTDOOR UNIT Error Method:
Current Sensor Error

Indicate or Display:
Outdoor Unit : E. 84. 1
Indoor Unit : Operation LED 8 times Flash, Timer LED 4 Times Flash, Economy LED Continuous Flash.
Error Code : 84

Detective Actuators:

Judgment from value sensed by current sensor (current sensor for inverter)
* Current sensor is mounted on Filter PCB

Detective details:

• When the compressor stops and 30seconds has passed, and the current value from INVERTER is over than 15A, outdoor unit is stopped permanently by protection.

Forecast of Cause : 1. Filter PCB to Inverter PCB CT system wiring connector disconnection, open
2. Filter PCB failure (Power supply section, current sensor section)
3. Inverter PCB failure

Check Point 1 : Filter PCB to Inverter PCB CT system wiring connection state

- Connector and wiring connection state check
- Cable open check

↓ OK

Check Point 2 : Check Filter PCB and Inverter PCB

▶ If Check Point 1 do not improve the symptom, replace Filter PCB.

↓ NG

Check Point 3 : Check Filter PCB and Inverter PCB

▶ If Check Point 2 do not improve the symptom, replace Inverter PCB.

Trouble shooting 27
OUTDOOR UNIT Error Method:
Discharge Pressure Sensor Error

Indicate or Display:
Outdoor Unit : E. 86. 1
Indoor Unit : Operation LED 8 times Flash, Timer LED 6 Times Flash, Economy LED Continuous Flash.
Error Code : 86

Detective Actuators:

Discharge pressure sensor

Detective details:

- When any of the following conditions is satisfied, a discharge pressure sensor error is generated.
 1. 30 seconds or more have elapsed since the outdoor unit power was turned on and pressure sensor detected value < 0.3V continued for 30 seconds or more
 2. 30 seconds or more have elapsed since the outdoor unit power was turned on and pressure sensor detected value \geq 5.0V was detected.

- Forecast of Cause :**
1. Discharge pressure sensor connector disconnection, open
 2. Discharge pressure sensor failure
 3. Main PCB failure

Check Point 1 : Check the discharge pressure sensor connection state

- Connector connection state check
- Cable open check



Check Point 2 : Check the discharge pressure sensor

- Sensor characteristics check
- * For the characteristics of the discharge pressure sensor, refer to the "Service Parts Information 6".



Check Point 3 : Check voltage of Main PCB (DC5.0V)

- Main PCB (CN91:1-4) voltage value = 5V
Remove the thermistor from Main PCB, check the voltage.

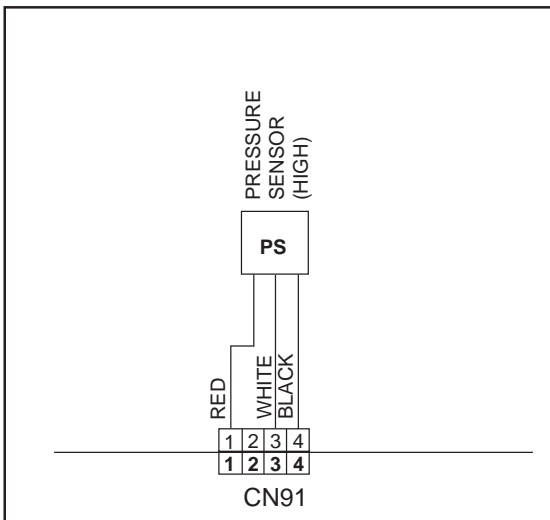

Discharge pressure sensor (CN91:1-4)

► If the voltage does not appear, replace Main PCB, and execute the check operation again.

Trouble shooting 28
OUTDOOR UNIT Error Method:
Suction Pressure Sensor Error

Indicate or Display:
Outdoor Unit : E. 86. 3
Indoor Unit : Operation LED 8 times Flash, Timer LED 6 Times Flash, Economy LED Continuous Flash.
Error Code : 86

Detective Actuators:

Suction pressure sensor

Detective details:

- When any of the following conditions is satisfied, a suction pressure sensor error is generated.
 1. 30 seconds or more have elapsed since the outdoor unit power was turned on and pressure sensor detected value < 0.06V continued for 30 seconds or more.
 2. 30 seconds or more have elapsed since the outdoor unit power was turned on and pressure sensor detected value $\geq 5.0V$ was detected.

- Forecast of Cause :**
1. Suction pressure sensor connector disconnection, open
 2. Suction pressure sensor failure
 3. Main PCB failure

Check Point 1 : Check the suction pressure sensor connection state

- Connector connection state check
- Cable open check



Check Point 2 : Check the suction pressure sensor

- Sensor characteristics check
- * For the characteristics of the suction pressure sensor, refer to the "Service Parts Information 6".



Check Point 3 : Check voltage of Main PCB (DC5.0V)



- Main PCB (CN92:1-3) voltage value = 5V
 Remove the thermistor from Main PCB, check the voltage.

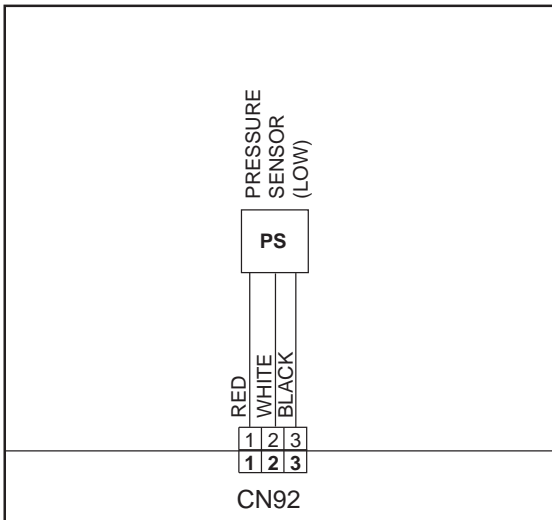

Suction pressure sensor (CN92:1-3)

► **If the voltage does not appear, replace Main PCB, and execute the check operation again.**

Trouble shooting 29 OUTDOOR UNIT Error Method: High Pressure Switch Error	Indicate or Display: Outdoor Unit : E. 86. 4 Indoor Unit : Operation LED 8 times Flash, Timer LED 6 Times Flash, Economy LED Continuous Flash. Error Code : 86
------------------------------------------------------------------------------------------------------	-----------------------------------------------------------------------------------------------------------------------------------------------------------------------------------------------------

Detective Actuators: High pressure switch	Detective details: • When the power was turned on, "high pressure switch : open" was detected.
-----------------------------------------------------	----------------------------------------------------------------------------------------------------------

Forecast of Cause : <ol style="list-style-type: none"> 1. High pressure switch connector disconnection, open 2. High pressure switch characteristics failure 3. Main PCB failure

Check Point 1 : Check the high pressure switch connection state

- Connector and wiring connection state check
- Cable open check

↓ **OK**

Check Point 2 : Check the high pressure switch characteristics

- Switch characteristics check
- * For the characteristics of high pressure switch, refer to below.

↓ **OK**

Check Point 3 : Replace Main PCB

- Change Main PCB, and execute the check operation again.

• Type of contact

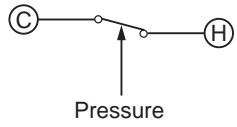

• Characteristics of pressure switch (CN101)

	Pressure switch 1
Contact : Short ⇒ Open	608.7±14.5 PSI
Contact : Open ⇒ Short	463.8±21.7 PSI

Trouble shooting 30
OUTDOOR UNIT Error Method:
Over Current Error

Indicate or Display:
Outdoor Unit : E. 94. 1
Indoor Unit : Operation LED 9 times Flash, Timer LED 4 Times Flash, Economy LED Continuous Flash.
Error Code : 94

Detective Actuators:

Inverter PCB

Detective details:

- "Protection stop by "overcurrent generation after inverter compressor start processing completed"" generated consecutively 10 times.
- * The number of generations is reset if the start-up of the compressor succeeds.

Forecast of Cause .: 1. Outdoor unit fan operation defective, foreign matter on hear exchanger, excessive rise of ambient temperature
2. Inverter PCB failure
3. Inverter compressor failure (lock, winding short)

Check Point 1 : Check the outdoor unit fan operation, heat exchanger, ambient temperature

- No obstructions in air passages?
- Heat exchange fins clogged
- Outdoor unit fan motor check
- Ambient temperature not raised by the effect of other heat sources?
- Discharged air not sucked in?

↓ OK

Check Point 2 : Check the Inverter PCB

- Inverter PCB check

↓ OK

Check Point 3 : Replace the Inverter compressor

- Inverter compressor replacement

Trouble shooting 31 <u>OUTDOOR UNIT Error Method:</u> Compressor Control Error	<u>Indicate or Display:</u> Outdoor Unit : E. 95. 1 Indoor Unit : Operation LED 9 times Flash, Timer LED 5 Times Flash Economy LED Continuous Flash. Error Code : 95
-----------------------------------------------------------------------------------------------------------	---------------------------------------------------------------------------------------------------------------------------------------------------------------------------------------------------------------------

<u>Detective Actuators:</u> Outdoor Unit Inverter PCBCompressor	<u>Detective details:</u> When "compressor location detection error" is detected consecutively 5 times, within 40 seconds after start-up. (Compressor location detection becomes over than 90°)
-------------------------------------------------------------------------------	------------------------------------------------------------------------------------------------------------------------------------------------------------------------------------------------------------------

<u>Forecast of Cause :</u> 1. Connector connection failure 2. Inverter PCB failure 3.Compressor failure

Check Point 1 : Check connections condition in control unit

- Check if the terminal connection is loose.
- Check if connector is removed.
- Check if connector is erroneous connection.
- Check if cable is open.

>> **Upon correcting the removed connector or mis-wiring, reset the power.**

↓ **OK**

Check Point 2 : Check the Inverter PCB to inverter compressor connection state

- Wiring connection state check
- Cable open check

↓ **OK**

Check Point 3 : Check the Inverter compressor

- Inverter compressor check (Refer to Service Parts Information 1. 2)

↓ **OK**

Check Point 4 : Replace the Inverter PCB

▶ **If Check Point 1~3 do not improve the symptom, replace Inverter PCB.**

↓ **NG**

Check Point 5 : Replace the Inverter compressor

▶ **If Check Point 4 do not improve the symptom, replace Inverter compressor.**

Trouble shooting 32 OUTDOOR UNIT Error Method: Outdoor Unit Fan Motor Error	Indicate or Display: Outdoor Unit : E. 97. 3 Indoor Unit : Operation LED 9 times Flash, Timer LED 7 Times Flash, Economy LED Continuous Flash. Error Code : 97
--------------------------------------------------------------------------------------------------------	-----------------------------------------------------------------------------------------------------------------------------------------------------------------------------------------------------

Detective Actuators: Outdoor unit fan motor Outdoor unit Main PCB	Detective details: ① When fan speed < 100rpm within 20 seconds after fan motor operation issued, fan motor is stopped by protection stop. ② When protection ① repeats 3 times within 60minutes, compressor and fan motor are stopped by protection stop. * The number of generations is reset if the protection ① not detects within 60 seconds. ③ When protection ② repeats 5 times, compressor and fan motor are stopped by protection stop. * The number of generations is reset if the protection ① not detects within 60 seconds after protection stop ②
--------------------------------------------------------------------------------	-------------------------------------------------------------------------------------------------------------------------------------------------------------------------------------------------------------------------------------------------------------------------------------------------------------------------------------------------------------------------------------------------------------------------------------------------------------------------------------------------------------------------------------------------------------------------------------

Forecast of Cause :	1. Rotation obstruction by foreign object 2. Motor wiring, connector disconnected, open 3. Fan motor failure (winding open, lock) 4. Main PCB failure (drive circuit, speed detection circuit)
----------------------------	---------------------------------------------------------------------------------------------------------------------------------------------------------------------------------------------------------

Check Point 1 : Fan rotation state check
<input type="checkbox"/> Check for the absence of foreign matter around the fan.



Check Point 2 : Check the motor wiring, connector disconnection, open
<input type="checkbox"/> Check for motor wiring connector disconnection, open.



Check Point 3 : Fan motor defective
<input type="checkbox"/> Check if fan can be rotated by hand. <input type="checkbox"/> Motor winding resistance check(PARTS INFORMATION 7) <input type="checkbox"/> Motor operation check



Check Point 4 : Check output voltage of Main PCB	
• Check outdoor unit circuit diagram and the voltage. (Measure at Main PCB side connector 243)	
>>1 pin(Red) - 4 pin(Black) DC250V ~ 400V >>4 pin(Black) - 5 pin(White) DC15V ±2V	
► If the voltage is not correct, replace Main PCB, and execute the check operation again.	

Trouble shooting 33 <u>OUTDOOR UNIT Error Method:</u> 4-way valve error	<u>Indicate or Display:</u> Outdoor Unit : E. 99. 1 Indoor Unit : Operation LED 9 times Flash, Timer LED 9 Times Flash Economy LED Continuous Flash. Error Code : 99
----------------------------------------------------------------------------------------------------	---------------------------------------------------------------------------------------------------------------------------------------------------------------------------------------------------------------------

<u>Detective Actuators:</u> Indoor Unit Controller PCB Circuit Heat Exchanger Temperature Thermistor Room Temperature Thermistor 4-way valve	<u>Detective details:</u> When the indoor heat exchanger temperature is compared with the room temperature, and either following condition is detected continuously two times, the compressor stops. •Cooling or Dry operation [Indoor heat exchanger temp.] - [Room temp.] > 50degF •Heating operation [indoor heat exchanger temp.] - [Room temp.] < -50degF If the same operation is repeated 2 times, the compressor stops permanently.
-----------------------------------------------------------------------------------------------------------------------------------------------------------------	----------------------------------------------------------------------------------------------------------------------------------------------------------------------------------------------------------------------------------------------------------------------------------------------------------------------------------------------------------------------------------------------------------------------------------------------------------------------

<u>Forecast of Cause :</u> 1. Connector connection failure 2. Thermistor failure 3. Coil failure 4. 4-way valve failure 5. Main PCB failure

Check Point 1 : Check connection of Connector
<ul style="list-style-type: none"> • Check if connector is removed. • Check erroneous connection. • Check if thermistor cable is open. >> <u>Upon correcting the removed connector or mis-wiring, reset the power.</u>

↓ **OK**

Check Point 2 : Check thermistor
<ul style="list-style-type: none"> • Isn't it fallen off the holder? • Is there a cable pinched? >> <u>Check characteristics of thermistor, If defective, replace the thermistor.</u>

↓ **OK**

Check Point 3 : Check the solenoid coil and 4-way valve
<p>[Solenoid coil]</p> <ul style="list-style-type: none"> • Remove CN30 from PCB and check the resistance value of coil. Resistance value is about 1.4kΩ >> <u>If it is Open or abnormal resistance value, replace Solenoid Coil.</u>
<p>[4-way valve]</p> <ul style="list-style-type: none"> • Check each piping temperature, and the location of the valve by the temperature difference. >> <u>If the value location is not proper, replace 4-way valve.</u>

↓ **OK**

Check Point 4 : Replace Main PCB
▶ <u>If Check Point 1- 3 do not improve the symptom, replace Main PCB, and execute the check operation again.</u>

Trouble shooting 34 OUTDOOR UNIT Error Method: Discharge Temp. Error	Indicate or Display: Outdoor Unit : E. A1. 1 Indoor Unit : Operation LED 10 times Flash, Timer LED 1 Times Flash, Economy LED Continuous Flash. Error Code : A1
-------------------------------------------------------------------------------------------------	------------------------------------------------------------------------------------------------------------------------------------------------------------------------------------------------------

Detective Actuators: Discharge temperature thermistor	Detective details: • "Protection stop by "discharge temperature \geq 239degF during compressor operation"" generated 2 times within 24 hours.
---------------------------------------------------------------------	---------------------------------------------------------------------------------------------------------------------------------------------------------------

Forecast of Cause : <ol style="list-style-type: none"> 1. 3-way valve not opened 2. EEV defective, strainer clogged 3. Outdoor unit operation failure, foreign matter on heat exchanger 4. Discharge temperature thermistor failure 5. Insufficient refrigerant

<Cooling operation>

Check Point 1 : Check if 3-way valve(gas side) is open.

If the 3-way valve(gas side) was closed, open the 3-way valve(gas side) and check operation.

↓
OK

Check Point 2 : Check the EEV, strainer

EEV (EEV2, indoor unit EEV) open?
 Strainer clogging check (before and after EEV, ACM oil return)
 Refer to "Service Parts Information 3, 4"

↓
OK

Check Point 3 : Check the outdoor unit fan,heat exchanger

Check for foreign object at heat exchanger
 Check if fan can be rotated by hand.
 Motor check(PARTS INFORMATION 7)

↓
OK

Check Point 4 : Check the discharge thermistor

Discharger thermistor characteristics check (Check by disconnecting thermistor from PCB.)
 * For the characteristics of the thermistor, refer to the "Service Parts Information 5".

↓
OK

Check Point 5 : Check the refrigerant amount

Leak check

<Heating operation>

Check Point 1 : Check if 3-way valve(liquid side) is open.

If the 3-way valve(liquid side) was closed, open the 3-way valve(liquid side) and check operation.

↓
OK

Check Point 2 : Check the EEV, strainer

EEV (EEV1, EEV2) open?
 Strainer clogging check (before and after EEV, ACM oil return)
 Refer to "Service Parts Information 3, 4"

↓
OK

Trouble shooting 35 OUTDOOR UNIT Error Method: Compressor Temp. Error	Indicate or Display: Outdoor Unit : E. A3. 1 Indoor Unit : Operation LED 10 times Flash, Timer LED 3 Times Flash, Economy LED Continuous Flash. Error Code : A3
--------------------------------------------------------------------------------------------------	------------------------------------------------------------------------------------------------------------------------------------------------------------------------------------------------------

Detective Actuators: Compressor temperature thermistor	Detective details: • "Protection stop by "compressor temperture" \geq 233degF during compressor operation""generated 2 times within 24 hours
----------------------------------------------------------------------	--------------------------------------------------------------------------------------------------------------------------------------------------------------

Forecast of Cause :	1. 3-way valve not opened 2. EEV defective, strainer clogged 3. Outdoor unit operation failure, foreign matter on heat exchanger 4. Compressor temperature thermistor failure 5. Insufficient refrigerant
----------------------------	-----------------------------------------------------------------------------------------------------------------------------------------------------------------------------------------------------------------------

<Cooling operation>

Check Point 1 : Check if 3-way valve(gas side) is open.

If the 3-way valve(gas side) was closed, open the 3-way valve(gas side) and check operation.

↓
OK

Check Point 2 : Check the EEV, strainer

EEV (EEV2, indoor unit EEV) open?
 Strainer clogging check (before and after EEV, ACM oil return)
 Refer to "Service Parts Information 3, 4".

↓
OK

Check Point 3 : Outdoor unit fan, heat exchanger chek

Check for foreign object at heat exchanger
 Check if fan can be rotated by hand.
 Motor check(PARTS INFORMATION 7)

↓
OK

Check Point 4 : Check the compressor temperature thermistor

Compressor temperature thermistor characteristics check (Check by disconnecting thermistor from PCB)
 * For the characteristics of the thermistor, refer to the "Service Parts Information 5.

↓
OK

Check Point 5 : Check the refrigerant amount

Leak check

<Heating operation>

Check Point 1 : Check if 3-way valve(liquid side) is open.

If the 3-way valve(liquid side) was closed, open the 3-way valve(liquid side) and check operation.

↓
OK

Check Point 2 : Check the EEV, strainer

EEV (EEV1, EEV2) open?
 Strainer clogging check (before and after EEV, ACM oil return)
 Refer to "Service Parts Information 3,4 ".

↙
OK

Trouble shooting 36 OUTDOOR UNIT Error Method: Low Pressure Error	Indicate or Display: Outdoor Unit : E. A5. 1 Indoor Unit : Operation LED 10 times Flash, Timer LED 5 Times Flash, Economy LED Continuous Flash. Error Code : A5
----------------------------------------------------------------------------------------------	------------------------------------------------------------------------------------------------------------------------------------------------------------------------------------------------------

Detective Actuators: Suction pressure sensor	Detective details: <ul style="list-style-type: none"> "Protection stop by suction pressure \leq 7.35PSI continued for 5 minutes" repeats 5 times within 2 hours.
--------------------------------------------------------	--------------------------------------------------------------------------------------------------------------------------------------------------------------------------------------------------------

Forecast of Cause :	1. 3-way valve not opened 2. Outdoor unit ambient temperature too low 3. Outdoor unit fan operation defective, foreign matter at heat exchanger 4. EEV defective, strainer clogged 5. Solenoid valve defective 6. Low pressure sensor characteristics defective 7. Insufficient refrigerant
----------------------------	------------------------------------------------------------------------------------------------------------------------------------------------------------------------------------------------------------------------------------------------------------------------------------------------------

<Cooling operation>

Check Point 1 : Check if 3-way valve(gas side) is open.
<input type="checkbox"/> If the 3-way valve(gas side) was closed, open the 3-way valve(gas side) and check operation.

OK

strainer clogging
<input type="checkbox"/> Indoor unit EEV operation check <input type="checkbox"/> Strainer not clogged?

OK

Check Point 5 : Check the solenoid valve (SV1)
<input type="checkbox"/> Solenoid valve operation check

OK

Check Point 6 : Check the suction pressure sensor
<input type="checkbox"/> Suction pressure sensor characteristics check * For the characteristics of the suction pressure sensor (PARTS INFORMATION 5)

OK

Check Point 7 : Check the refrigerant amount
<input type="checkbox"/> Leak check

<Heating operation>

Check Point 1 : Check if 3-way valve(liquid side) is open.
<input type="checkbox"/> If the 3-way valve(liquid side) was closed, open the 3-way valve(liquid side) and check operation.

OK

Check Point 2 : Check the outdoor unit ambient temperature
<input type="checkbox"/> Outdoor ambient temperature lower than operating range?

OK

Check Point 3 : Check the outdoor unit fan operation, heat exchanger
<input type="checkbox"/> No foreign object in air passage? <input type="checkbox"/> Heat exchange fins clogged <input type="checkbox"/> Fan rotates? <input type="checkbox"/> Outdoor unit fan motor check

OK

Check Point 4 : Check the outdoor unit EEV, strainer clogging
<input type="checkbox"/> Outdoor unit EEV1 operation check <input type="checkbox"/> Strainer not clogged? Refer to "Service Parts Information 3"

←

<p>Trouble shooting 37 Branch Box Error Method: Connected combination error</p>	<p>Indicate or Display: Outdoor Unit : E. 11. 3 Branch Box : LED401/ 402/ 403/ 404/ 405 Lit Indoor Unit : Operation LED 1times Flash, Timer LED 1times Flash, Economy LED Flashing (0.1s ON / 0.1s OFF) Error Code : 11</p>
----------------------------------------------------------------------------------------------------------------	------------------------------------------------------------------------------------------------------------------------------------------------------------------------------------------------------------------------------------------------------------------------------------

<p><u>Detective Actuators:</u> Outdoor unit</p>	<p><u>Detective details:</u> • When another outdoor unit in the future is connected to the terminal "Outdoor unit" of Primary branch box.</p>
-------------------------------------------------------------	-----------------------------------------------------------------------------------------------------------------------------------------------------------

Forecast of Cause : 1. Connected outdoor unit

<p>Check Point 1 : Check the outdoor unit</p>
<p><input type="checkbox"/> Check the outdoor unit >> <u>If there is another outdoor unit, correct it by referring to Installation Manual or Design & Technical Manual.</u> >> <u>Upon correcting incorrect setting, reset the power.</u></p>

Trouble shooting 38 Branch Box Error Method: Power frequency error 1	Indicate or Display: Outdoor Unit : E. 11. 3 or E. 11. 4 Branch Box : LED401/ 402/ 403/ 404 Lit, LED405 Unlit Indoor Unit : Operation LED 1times Flash, Timer LED 1times Flash, Economy LED Flashing (0.1s ON / 0.1s OFF) Error Code : 11
-------------------------------------------------------------------------------------------------	------------------------------------------------------------------------------------------------------------------------------------------------------------------------------------------------------------------------------------------------------------------------------------------

Detective Actuators: Branch Box Controller PCB	Detective details: • When 4 continuous failures occurred at Power frequency test. (Power supply of Branch Box)
----------------------------------------------------------	-----------------------------------------------------------------------------------------------------------------------------

Forecast of Cause : 1. Connection failure 2. External cause 3. Controller PCB failure

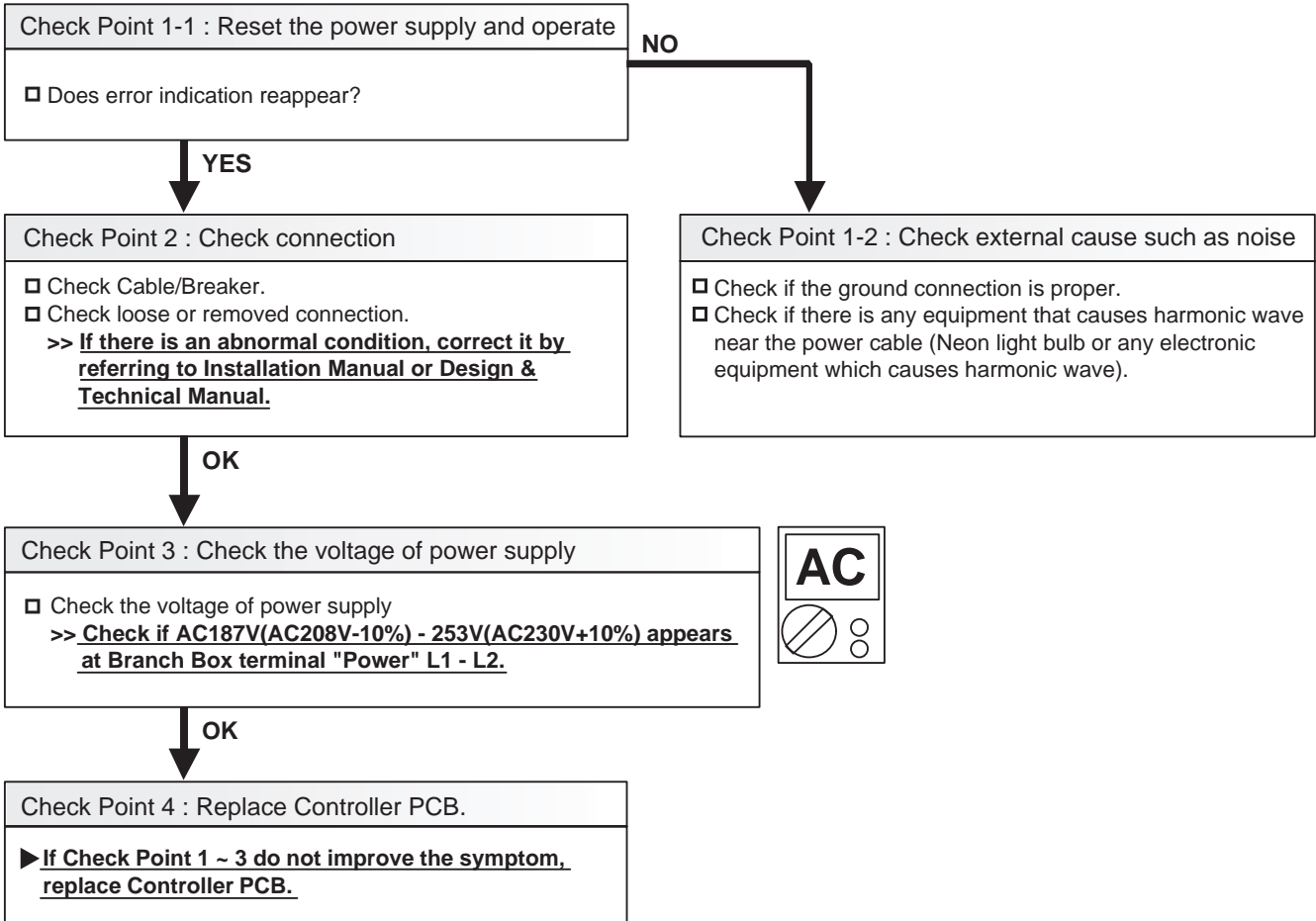

Trouble shooting 39 Branch Box Error Method: Power frequency error 2	Indicate or Display: Outdoor Unit : E. 11. 3 or E. 11. 4 Branch Box : LED401/ 402/ 403 Lit, LED404 Unlit, LED405 Lit Indoor Unit : Operation LED 1times Flash, Timer LED 1times Flash, Economy LED Flashing (0.1s ON / 0.1s OFF) Error Code : 11
-------------------------------------------------------------------------------------------------	-------------------------------------------------------------------------------------------------------------------------------------------------------------------------------------------------------------------------------------------------------------------------------------------------

Detective Actuators: Branch Box Controller PCB Outdoor unit Main PCB Outdoor Filter PCB	Detective details: <ul style="list-style-type: none"> • When 4 continuous failures occurred at Power frequency test. (Branch Box (Primary) : Power supply for communication to outdoor unit. Branch Box (Secondary) : Power supply for communication to primary branch box.)
---------------------------------------------------------------------------------------------------------	-----------------------------------------------------------------------------------------------------------------------------------------------------------------------------------------------------------------------------------------------------------------------------------------------------------------------

Forecast of Cause : 1. Connection failure 2. External cause 3. Controller PCB failure 4. Outdoor Main PCB failure 5. Outdoor Filter PCB failure

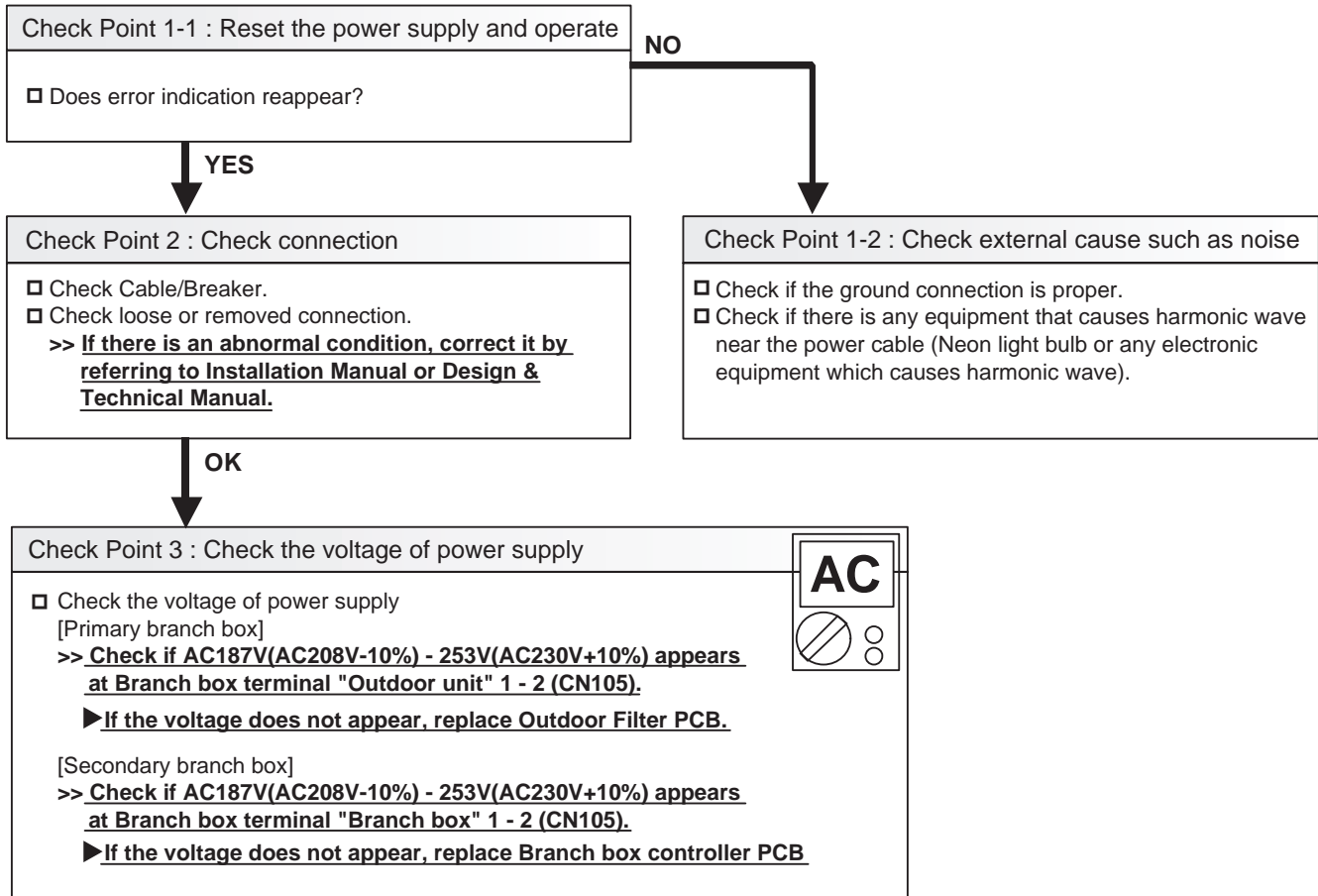

Trouble shooting 40 Branch Box Error Method: EEPROM access error	Indicate or Display: Outdoor Unit : E. J2. U Branch Box : LED402 1time Flash, LED403/ 404/ 405 Unlit Indoor Unit : Operation LED 13times Flash, Timer LED 2times Flash, Economy LED Flashing (0.1s ON / 0.1s OFF) Error Code : J2
---------------------------------------------------------------------------------------------	----------------------------------------------------------------------------------------------------------------------------------------------------------------------------------------------------------------------------------------------------------------------------------

Detective Actuators: Branch Box Controller PCB	Detective details: • When power is on and the access to EEPROM failed.
----------------------------------------------------------	----------------------------------------------------------------------------------

Forecast of Cause : 1. External cause 2. Defective for connection in controller unit 3. Controller PCB failure

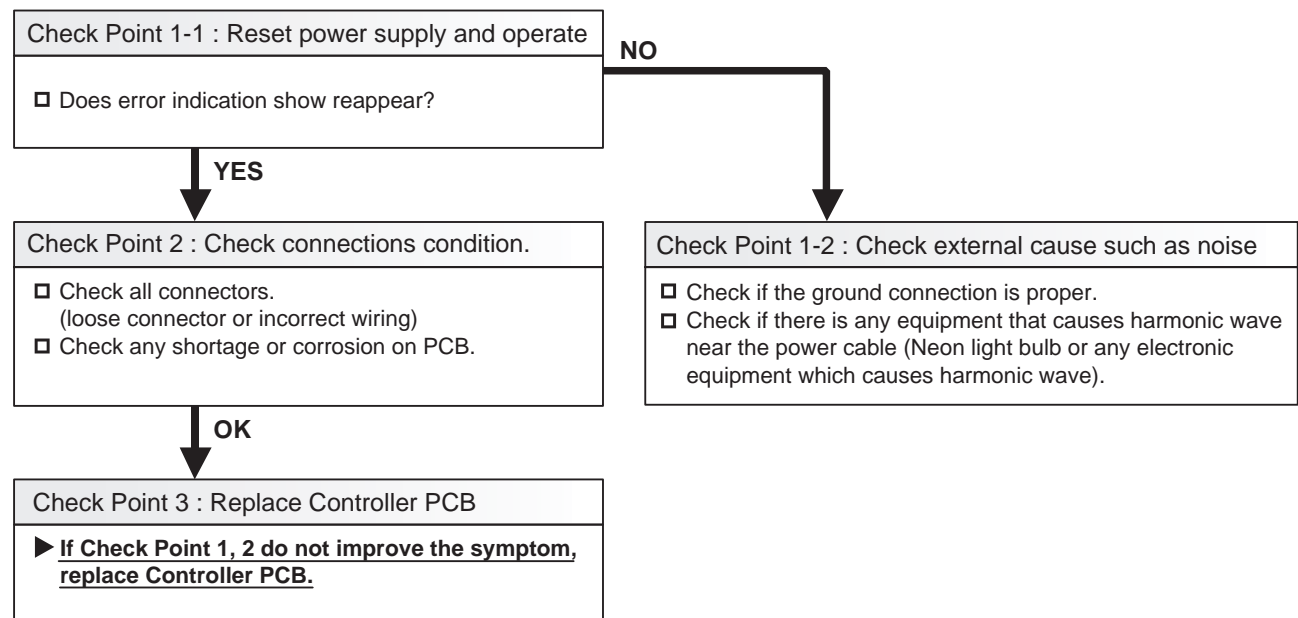

Trouble shooting 41 Branch Box Error Method: Model information error	Indicate or Display: Outdoor Unit : E. J2. U Branch Box : LED402 2times Flash, LED403/ 404/ 405 Unlit Indoor Unit : Operation LED 13times Flash, Timer LED 2times Flash, Economy LED Flashing (0.1s ON / 0.1s OFF) Error Code : J2
-------------------------------------------------------------------------------------------------	-----------------------------------------------------------------------------------------------------------------------------------------------------------------------------------------------------------------------------------------------------------------------------------

Detective Actuators: Branch Box Controller PCB	Detective details: · When power is on and model information of EEPROM is incorrect.
----------------------------------------------------------	-----------------------------------------------------------------------------------------------

Forecast of Cause : 1. External cause 2. Defective for connection in controller unit 3. Controller PCB failure

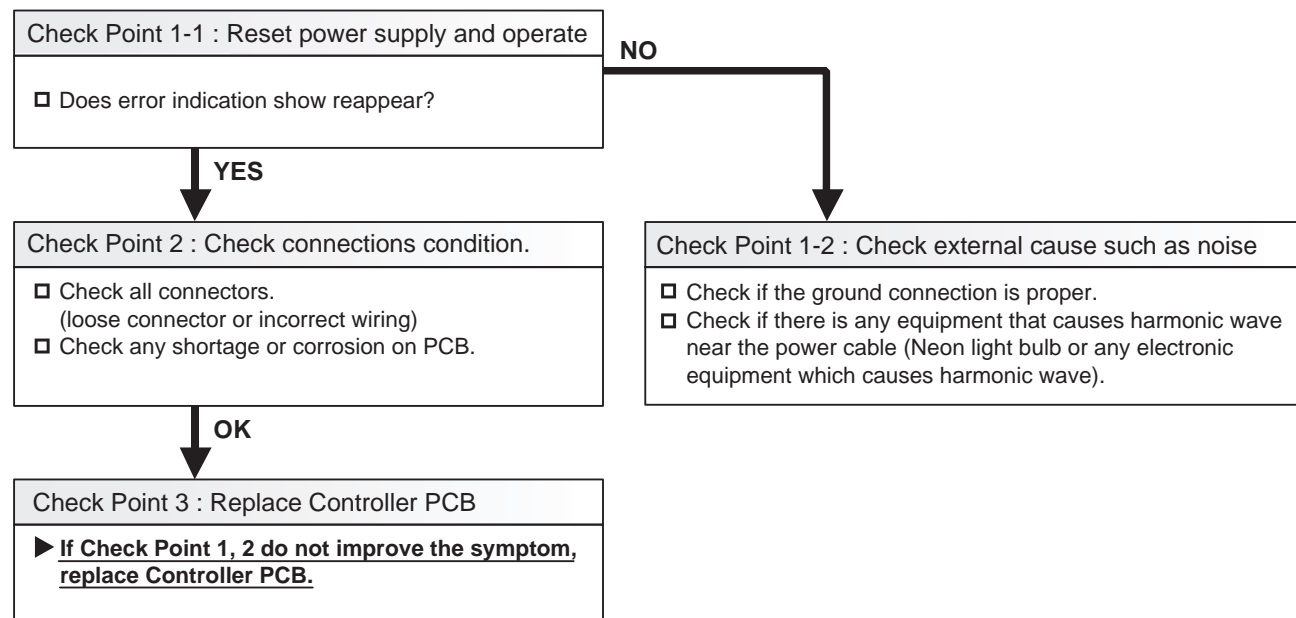

Trouble shooting 42 Branch Box Error Method: Indoor Unit A, B, C, liquid pipe thermistor error (CN309 / 310)	Indicate or Display: Outdoor Unit : E. J2. U Branch Box : LED402 6times Flash (Indoor unit A): LED403 Lit, LED404/ 405 Unlit (Indoor unit B): LED403 Unlit, LED404 Lit, LED405 Unlit (Indoor unit C): LED403/ 404 Unlit, LED405 Lit Indoor Unit : Operation LED 13times Flash, Timer LED 2times Flash, Economy LED Flashing (0.1s ON / 0.1s OFF) Error Code : J2
-----------------------------------------------------------------------------------------------------------------------------------------	--------------------------------------------------------------------------------------------------------------------------------------------------------------------------------------------------------------------------------------------------------------------------------------------------------------------------------------------------------------------------------------------------------------------------

Detective Actuators: Branch Box Controller PCB Indoor unit A,B,C Liquid pipe Thermistor	Detective details: · When open or shorted Liquid pipe Thermistor is detected.
------------------------------------------------------------------------------------------------------	-----------------------------------------------------------------------------------------

Forecast of Cause : 1. Connection failure 2. Thermistor failure 3. Controller PCB failure

Check Point 1 : Check connection of Connector

- Check if connector is loose or removed
- Check erroneous connection
- Check if thermistor cable is open

>>Reset Power when reinstalling due to removed connector or incorrect wiring.



Check Point 2 : Remove connector and check Thermistor resistance value

Thermistor Characteristics (Rough value)

Temperature (°F)	32	41	50	59	68	77	86	95
Resistance Value (kΩ)	168.6	129.8	100.9	79.1	62.5	49.8	40.0	32.4

Temperature (°F)	104	113	122
Resistance Value (kΩ)	26.3	21.2	17.8



► **If Thermistor is either open or shorted, replace it and reset the power.**



Check Point 3 : Check voltage of Controller PCB (DC5.0V)

Make sure circuit diagram of each indoor unit and check terminal voltage at Thermistor (DC5.0V)

- Schematic Diagram (Connector connection)

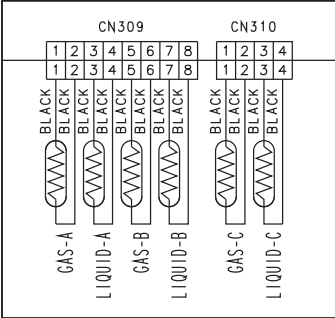

- Liquid pipe Thermistor (Unit A) (CN309 Wire:Black)
- Liquid pipe Thermistor (Unit B) (CN309 Wire:Black)
- Gas pipe Thermistor (Unit A) (CN309 Wire:Black)
- Gas pipe Thermistor (Unit B) (CN309 Wire:Black)
- Liquid pipe Thermistor (Unit C) (CN310 Wire:Black)
- Gas pipe Thermistor (Unit C) (CN310 Wire:Black)



► **If the voltage does not appear, replace Controller PCB .**

<p>Trouble shooting 43 Branch Box Error Method: Indoor Unit A, B, C, gas pipe thermistor error (CN309 / 310)</p>	<p>Indicate or Display: Outdoor Unit : E. J2. U Branch Box : LED402 7times Flash (Indoor unit A): LED403 Lit, LED404/ 405 Unlit (Indoor unit B): LED403 Unlit, LED404 Lit, LED405 Unlit (Indoor unit C): LED403/ 404 Unlit, LED405 Lit Indoor Unit : Operation LED 13times Flash, Timer LED 2times Flash, Economy LED Flashing (0.1s ON / 0.1s OFF) Error Code : J2</p>
-------------------------------------------------------------------------------------------------------------------------------------------------	-----------------------------------------------------------------------------------------------------------------------------------------------------------------------------------------------------------------------------------------------------------------------------------------------------------------------------------------------------------------------------------------------------------------------------------------------------------------------

<p>Detective Actuators: Branch Box Controller PCB Circuit Indoor unit A,B,C Gas pipe Thermistor</p>	<p>Detective details: • When open or shorted Liquid pipe Thermistor is detected.</p>
--------------------------------------------------------------------------------------------------------------------------------------	----------------------------------------------------------------------------------------------------------

Forecast of Cause : 1. Connection failure 2. Thermistor failure 3. Controller PCB failure

Check Point 1 : Check connection of Connector

- Check if connector is loose or removed
- Check erroneous connection
- Check if thermistor cable is open

>>Reset Power when reinstalling due to removed connector or incorrect wiring.



Check Point 2 : Remove connector and check Thermistor resistance value

Thermistor Characteristics (Rough value)

Temperature (°F)	32	41	50	59	68	77	86	95
Resistance Value (kΩ)	168.6	129.8	100.9	79.1	62.5	49.8	40.0	32.4

Temperature (°F)	104	113	122
Resistance Value (kΩ)	26.3	21.2	17.8

► If Thermistor is either open or shorted, replace it and reset the power.



Check Point 3 : Check voltage of Controller PCB (DC5.0V)

Make sure circuit diagram of each indoor unit and check terminal voltage at Thermistor (DC5.0V)

• Schematic Diagram (Connector connection)

- Liquid pipe Thermistor (Unit A) (CN309 Wire:Black)
- Liquid pipe Thermistor (Unit B) (CN309 Wire:Black)
- Gas pipe Thermistor (Unit A) (CN309 Wire:Black)
- Gas pipe Thermistor (Unit B) (CN309 Wire:Black)
- Liquid pipe Thermistor (Unit C) (CN310 Wire:Black)
- Gas pipe Thermistor (Unit C) (CN310 Wire:Black)

► If the voltage does not appear, replace Controller PCB .

<p>Trouble shooting 44 Branch Box Error Method: Indoor Unit A, B, C, EEV control error (CN305 / 306 / 307)</p>	<p>Indicate or Display: Outdoor Unit : E. J2. U Branch Box : LED402 8times Flash (Indoor unit A): LED403 Lit, LED404/ 405 Unlit (Indoor unit B): LED403 Unlit, LED404 Lit, LED405 Unlit (Indoor unit C): LED403/ 404 Unlit, LED405 Lit Indoor Unit : Operation LED 13times Flash, Timer LED 2times Flash, Economy LED Flashing (0.1s ON / 0.1s OFF) Error Code : J2</p>
-----------------------------------------------------------------------------------------------------------------------------------------------	--------------------------------------------------------------------------------------------------------------------------------------------------------------------------------------------------------------------------------------------------------------------------------------------------------------------------------------------------------------------------------------------------------------------------------------------------------------------

<p>Detective Actuators: Branch Box Controller PCB EEV</p>	<p>Detective details:</p> <ol style="list-style-type: none"> ① In cooling or dry operation, when the Indoor unit heat exchanger temperature becomes lower than 3degC for 5minutes,the compressor stops and EEV is initialized. ② After the compressor restarts, if the same protection is repeated within 1hr, the compressor stops permanently.
----------------------------------------------------------------------------	---------------------------------------------------------------------------------------------------------------------------------------------------------------------------------------------------------------------------------------------------------------------------------------------------------------------------------------------------------------------------------

Forecast of Cause : 1. Connection failure 2. EEV failure 3. Controller PCB failure

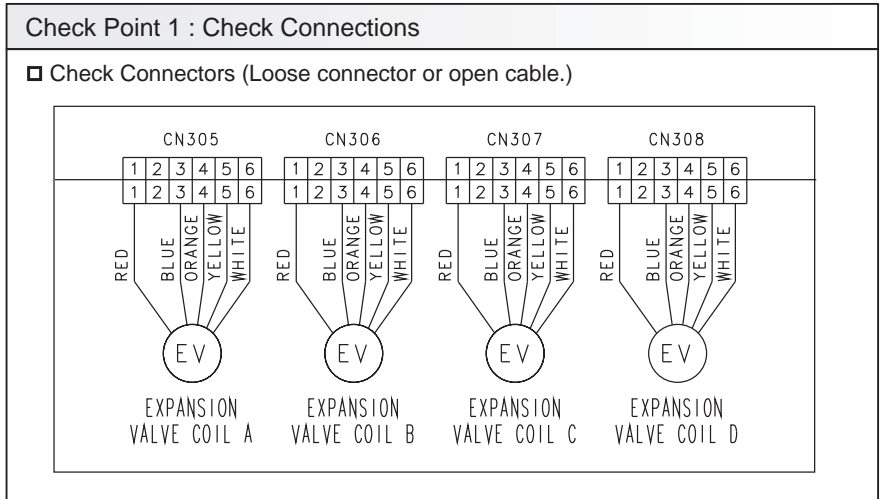

↓
OK

Check Point 2 : Check Coil of EEV

☐ Remove connector, check each winding resistance of Coil.

Read wire	Resistance value (68°F)
White - Red	46Ω ± 4Ω
Yellow - Red	
Orange - Red	
Blue - Red	

▶ **If Resistance value is abnormal, replace EEV.**



↓
OK

Check Point 3 : Check Voltage from Controller PCB

☐ Remove Connector and check Voltage (DC12V).
>> **If it does not appear, replace Controller PCB.**



↓
OK

↓ OK

Check Point 4 : Check Noise at start up

□ Turn on Power and check operation noise.
>> If an abnormal noise does not show, replace Controller PCB.

↓ OK

Check Point 5 : Check Opening and Closing Operation of Valve

When Valve is closed,
it has a temp. difference between Inlet and Outlet.

If it is open,
it has no temp. difference between Inlet and Outlet.

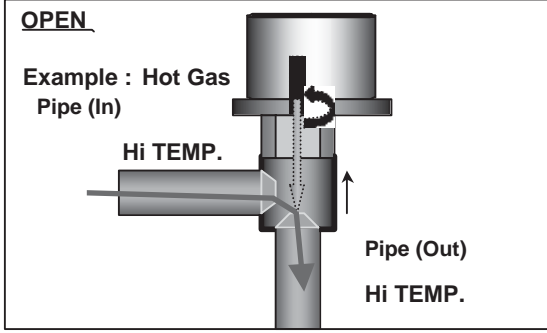
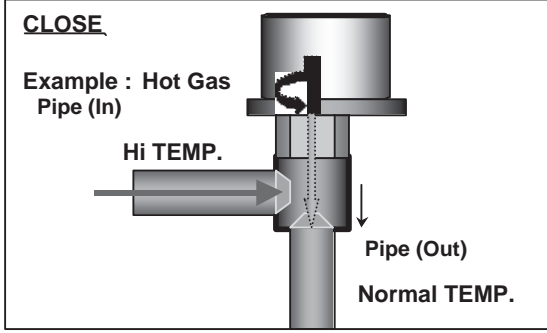

↓ OK

Check Point 6 : Check Strainer

Strainer normally does not have temperature difference between inlet and outlet as shown in (1), but if there is a difference as shown in (2), there is a possibility of inside clogged. In this case, replace Strainer.

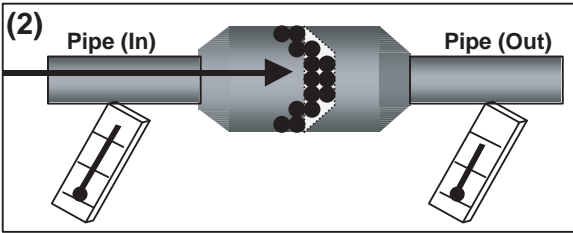
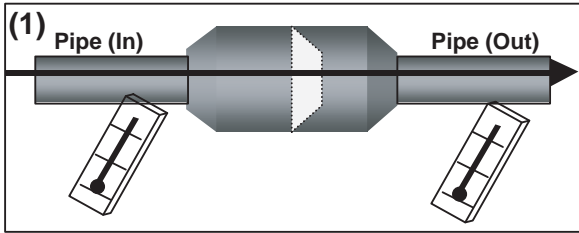

Trouble shooting 45 Branch Box Error Method: Remote controller communication error	Indicate or Display: Outdoor Unit : E. J2. U Branch Box : LED402 9times Flash, LED403/ 404/ 405 unlit Indoor Unit : Operation LED 13times Flash, Timer LED 2times Flash, Economy LED Flashing (0.1s ON / 0.1s OFF) Error Code : J2
---------------------------------------------------------------------------------------------------------------	-----------------------------------------------------------------------------------------------------------------------------------------------------------------------------------------------------------------------------------------------------------------------------------

Detective Actuators: Branch Box Controller PCB Home controller	Detective details: <ul style="list-style-type: none"> ▪ More than 1 time of signal from Home controller and other Branch box is received, but it was not received more than 1 minute. ▪ Upon receiving the signal more than 1 time from Home controller, but the same signal has not been received more than 1 minute.
-----------------------------------------------------------------------------	-------------------------------------------------------------------------------------------------------------------------------------------------------------------------------------------------------------------------------------------------------------------------------------------------------------------------------------------------------

Forecast of Cause : 1. Terminal connection abnormal 2. Home Controller failure 3. Controller PCB failure

Check Point 1 : Check the connection of terminal

After turning off the power, check & correct the followings.

Branch box - Check the connection of terminal between Home controller and Branch box, or between other Branch boxes, and check if there is a disconnection or short of the cable.



Check Point 2 : Check Home controller and Controller PCB

Check terminal voltage of controller PCB Connector (CN304). (Power supply for Home controller)
If DC12V, Home controller failure (Controller PCB is OK) >>> Replace Home controller
If DC0V, Controller PCB failure (Remote is OK) >>> Replace Controller PCB

▶ In case of re-installation is done due to removed connector or incorrect wiring, turn on the power again.



Trouble shooting 46 <u>OUTDOOR UNIT Error Method:</u> Display P.C.B. Communication Error	<u>Indicate or Display:</u> Outdoor Unit : E. 6A. 1 Indoor Unit : Operation LED 6 times Flash, Timer LED 10 Times Flash, Economy LED Continuous Flash. Error Code : 6A
---------------------------------------------------------------------------------------------------------------------	-------------------------------------------------------------------------------------------------------------------------------------------------------------------------------------------------------------

<u>Detective Actuators:</u> Outdoor unit Main PCB Outdoor unit I/O PCB	<u>Detective details:</u> • Communication not received from I/O PCB for 10 seconds or more
-------------------------------------------------------------------------------------	------------------------------------------------------------------------------------------------------

<u>Forecast of Cause :</u> <ol style="list-style-type: none"> 1. Main to I/O PCBs wiring connection defective 2. I/O PCB defective 3. Main PCB defective

Check Point 1 : Check the I/O to Main PCB wiring
<input type="checkbox"/> Connector and wiring connection state check <input type="checkbox"/> Cable open check



Check Point 2 : Check I/O PCB and Main PCB
<input type="checkbox"/> If there is the error display at the I/O PCB >> I/O PCB or Main PCB is defective >> Replace I/O PCB or Main PCB <input type="checkbox"/> If there is not the error display at the I/O PCB >> I/O PCB is defective >> Replace I/O PCB <input type="checkbox"/> If Outdoor unit error code is "E.6A.1" and Indoor unit error code is "E.11.1" or "E.11.2" (E.11.1 and E.11.2 is Serial reverse transfer error) >> Main PCB is defective >> Replace Main PCB

Trouble shooting 47-1
INDOOR UNIT Error Method:

Damper error
(Damper(Open/Close) detection Limit switch error)

Indicate or Display:

Outdoor Unit : E. 5U. 1
Indoor Unit : Operation LED 5 times Flash, Timer LED 7 Times Flash,
Economy LED Continuous Flash.
Error Code : 57

Detective Actuators:

Indoor unit Controller PCB
Limit switch
Damper

Detective details:

When limit switch were not able to detect the close though the damper close.
(Upper air flow)
When limit switch were not able to detect the open though the damper open.
(Upper & Lower air flow)

Forecast of Cause :

1. Limit switch failure
2. Shorted connector/ wire
3. Damper failure
4. Controller PCB failure

Check Point 1 : Check Limit switch

- Check operation of limit switch. (any blocking by dust, etc.)
- Remove Limit switch and check ON/OFF switching operation by using a meter.

>>If Limit switch is detective, replace it.



OK

Check Point 2 : Check Connector (CN18) / Wire

- Check loose contact of CN18 /shorted wire (pinched wire).

>>Replace Limit switch if the wire is abnormal

OK

Check Point 3 : Check Damper

- Check the obstruction of damper movement.
- Check the damper movement.

>>Replace Damper if the damper is abnormal

OK

Check Point 4 : Replace Controller PCB

► If Check Point 1~3 do not improve the symptom, change Controller PCB.

<p>Trouble shooting 47-2 INDOOR UNIT Error Method: Damper error (Damper(Open/Close) simultaneous detection Limit switch error)</p>	<p>Indicate or Display: Outdoor Unit : E. 5U. 1 Indoor Unit : Operation LED 5 times Flash, Timer LED 7 Times Flash, Economy LED Continuous Flash. Error Code : 57</p>
-----------------------------------------------------------------------------------------------------------------------------------------------------------------------------	--------------------------------------------------------------------------------------------------------------------------------------------------------------------------------------------------

<p>Detective Actuators: Indoor unit Controller PCB Limit switch</p>	<p>Detective details: When the limit switch detects open and close at the simultaneous.</p>
--------------------------------------------------------------------------------------	---------------------------------------------------------------------------------------------------------

Forecast of Cause :
1. Limit switch failure 2. Shorted connector/ wire 3. Controller PCB failure

Check Point 1 : Check Limit switch

- Check operation of limit switch. (any blocking by dust, etc.)
- Remove Limit switch and check ON/OFF switching operation by using a meter.

>>If Limit switch is detective, replace it.

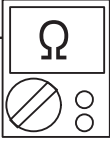

Check Point 2 : Check Connector (CN18) / Wire

- Check loose contact of CN18 /shorted wire (pinched wire).

>>Replace Limit switch if the wire is abnormal



Check Point 3 : Replace Controller PCB

▶ If Check Point 1 & 2 do not improve the symptom, change Controller PCB.

Trouble shooting 48 INDOOR UNIT Error Method: Intake Grille Error	Indicate or Display: Outdoor Unit : E. 5U. 1 Indoor Unit : Operation LED 5 times Flash, Timer LED 8 Times Flash, Economy LED Continuous Flash. Error Code : 58
----------------------------------------------------------------------------------------------	-----------------------------------------------------------------------------------------------------------------------------------------------------------------------------------

Detective Actuators: Indoor unit Controller PCB Micro switch	Detective details: When the Micro switch is detected open while running the compressor.
---------------------------------------------------------------------------	---------------------------------------------------------------------------------------------------

Forecast of Cause : 1. Micro switch failure 2. Shorted connector/ wire 3.Controller PCB failure

Check Point 1 : Check Limit switch <ul style="list-style-type: none"> · Check operation of Micro switch. (any blocking by dust, etc.) · Remove Micro switch and check ON/OFF switching operation by using a meter. >>If Micro switch is detective, replace it.	
---------------------------------------------------------------------------------------------------------------------------------------------------------------------------------------------------------------------------------------------------------------------------------------------------------------	-------------------------------------------------------------------------------------

↓
OK

Check Point 2 : Check Connector (CN11) / Wire <ul style="list-style-type: none"> · Check loose contact of CN11 /shorted wire (pinched wire). >>Replace Micro switch if the wire is abnormal

↓
OK

Check Point 3 : Replace Controller PCB ▶ If Check Point 1 & 2 do not improve the symptom, change Controller PCB.

2-5 SERVICE PARTS INFORMATION

SERVICE PARTS INFORMATION 1

Compressor

Diagnosis method of Compressor (If outdoor unit LED displays error, refer to Trouble shooting)

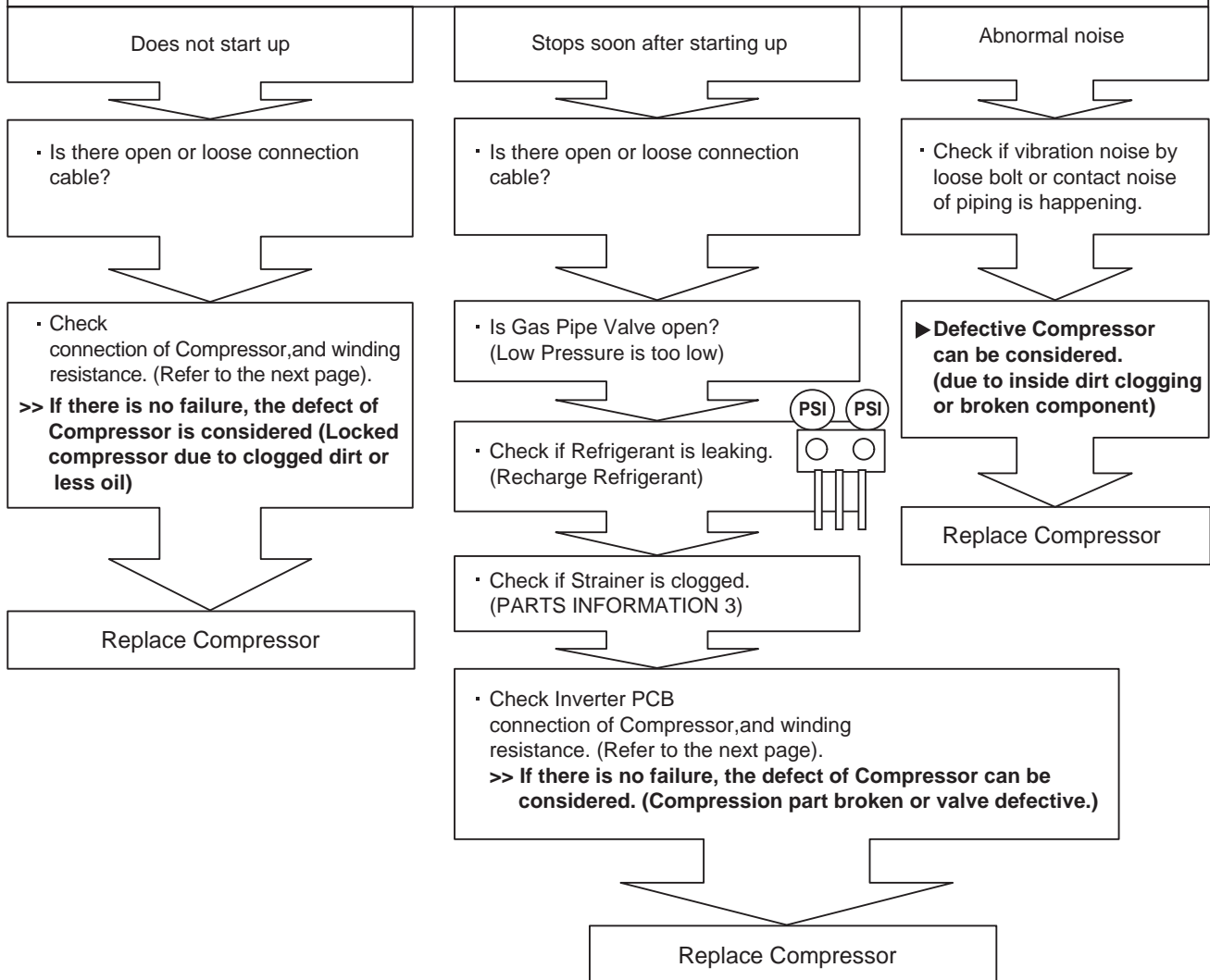

SERVICE PARTS INFORMATION 2

Compressor

Check Point 1 : Check connection

- Check terminal connection of Compressor (Loose or incorrect wiring)

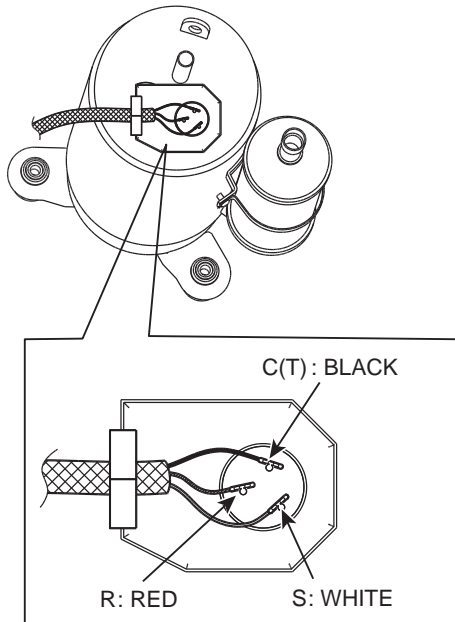

- Check connection of Inverter PCB (Loose or incorrect wiring)

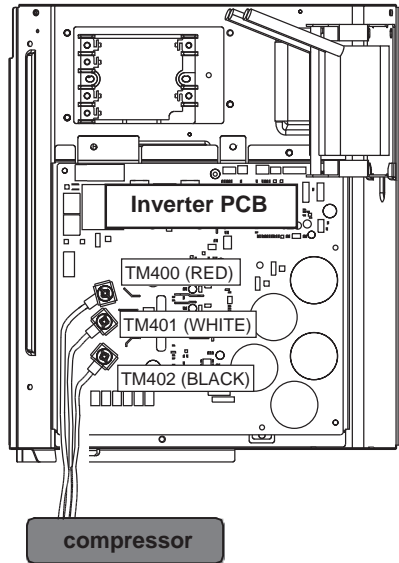

Check Point 2 : Check winding resistance

- Check winding resistance of each terminal
- ▶ **If the resistance value is 0 Ω or infinite, replace Compressor.**

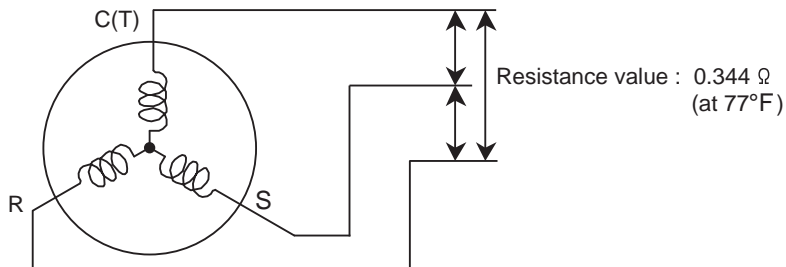

Check Point 3 : Replace Inverter PCB

- ▶ **If Check Point 1, 2 do not improve the symptom, replace Inverter PCB.**

SERVICE PARTS INFORMATION 3

Outdoor Unit Electronic Expansion Valve (EEV1)

Check Point 1 : Check Connections

- ❑ Check connection of connector (CN111)
(Loose connector or open cable)

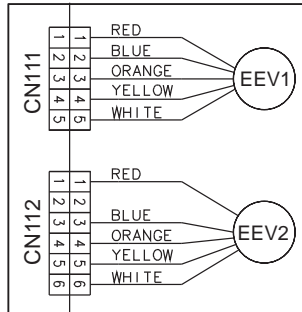

Check Point 2 : Check Coil of EEV

- ❑ Remove connector, check each winding resistance of Coil.

Read wire	Resistance value (68°F)
White - Red	46Ω ± 4Ω
Yellow - Red	
Orange - Red	
Blue - Red	

▶ **If Resistance value is abnormal, replace EEV.**

Check Point 3 : Check Voltage from Controller PCB

- ❑ Remove Connector and check Voltage (DC12V).

>> **If it does not appear, replace Controller PCB.**



Check Point 4 : Check Noise at start up

- ❑ Turn on Power and check operation noise.

>> **If an abnormal noise does not show, replace Controller PCB.**

Check Point 5 : Check Opening and Closing Operation of Valve

When Valve is closed,
it has a temp. difference between Inlet and Outlet.

CLOSE

Example : Hot GUS
Pipe (In)

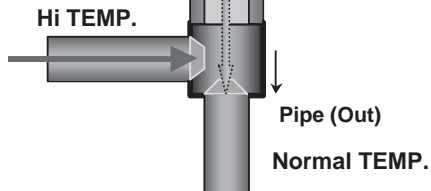

If it is open,
it has no temp. difference between Inlet and Outlet.

OPEN

Example : Hot GUS
Pipe (In)

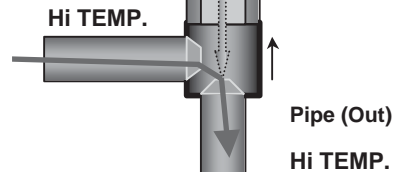

Check Point 6 : Check Strainer

Strainer normally does not have temperature difference between inlet and outlet as shown in (1), but if there is a difference as shown in (2), there is a possibility of inside clogged. In this case, replace Strainer.

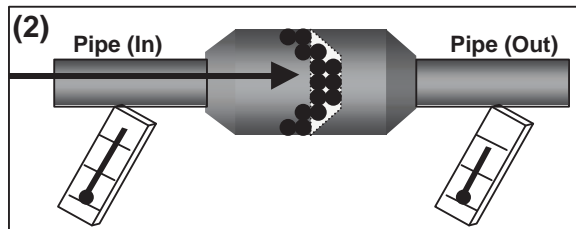
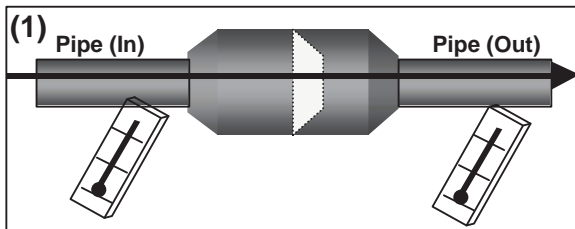

SERVICE PARTS INFORMATION 4

Outdoor Unit Electronic Expansion Valve (EEV2)

Check Point 1 : Check Connections

- Check connection of connector (CN112)
(Loose connector or open cable)

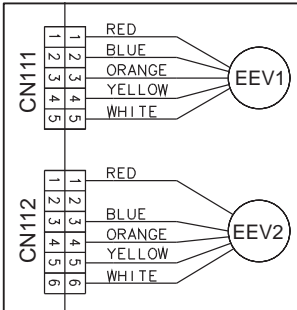

Check Point 2 : Check Coil of EEV

- Remove connector, check each winding resistance of Coil.

Read wire	Resistance value (68°F)
White - Red	46Ω ± 4Ω
Yellow - Red	
Orange - Red	
Blue - Red	

▶ **If Resistance value is abnormal, replace EEV.**

Check Point 3 : Check Voltage from Controller PCB

- Remove Connector and check Voltage (DC12V).

>> **If it does not appear, replace Controller PCB.**



Check Point 4 : Check Noise at start up

- Turn on Power and check operation noise.

>> **If an abnormal noise does not show, replace Controller PCB.**

Check Point 5 : Check Opening and Closing Operation of Valve

When Valve is closed, it has a temp. difference between Inlet and Outlet.

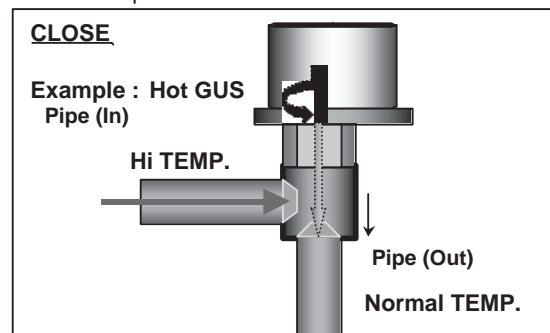

If it is open, it has no temp. difference between Inlet and Outlet.

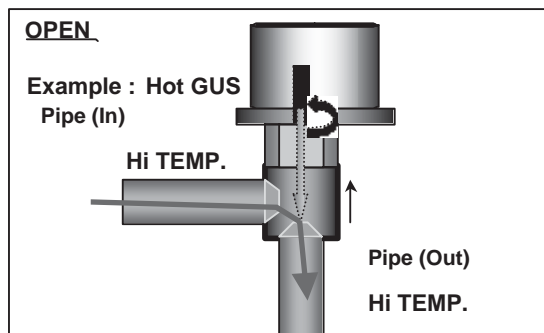

Check Point 6 : Check Strainer

Strainer normally does not have temperature difference between inlet and outlet as shown in (1), but if there is a difference as shown in (2), there is a possibility of inside clogged. In this case, replace Strainer.

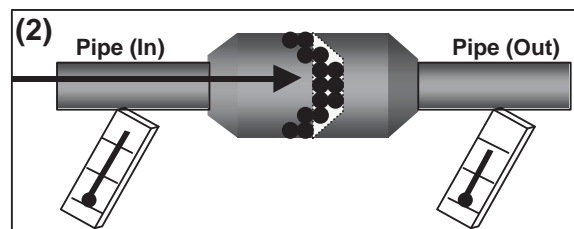
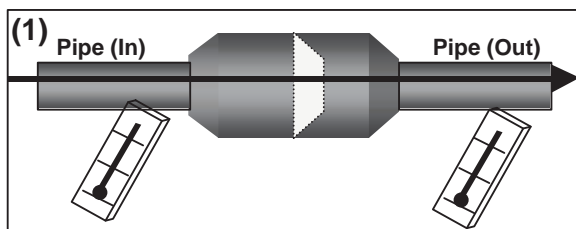

SERVICE PARTS INFORMATION 5

Thermistor

Check Point : Check Thermistor resistance value

□ Remove connector and check Thermistor resistance value.

Temperature [°F]	Resistance Value [kΩ]			
	Thermistor A	Thermistor B	Thermistor C	Thermistor D
- 4	---	---	105.4	---
14	---	27.8	58.2	27.4
23	---	21.0	44.0	20.7
32	168.6	16.1	33.6	15.8
41	129.8	12.4	25.9	12.2
50	100.9	9.6	20.2	9.5
59	79.1	7.6	15.8	7.5
68	62.6	6.0	12.5	5.9
77	49.8	4.8	10.0	4.7
86	40.0	3.8	8.0	3.8
104	26.3	2.5	5.3	2.5
122	17.8	1.7	3.6	1.7
140	12.3	1.2	---	1.2
158	8.7	---	---	0.8
176	6.3	---	---	0.6
194	4.6	---	---	0.4
212	3.4	---	---	0.3
230	2.6	---	---	---
248	2.0	---	---	---
Applicable Thermistors	Discharge temp. TH Comprssor temp. TH	Heat exchanger. TH Suction temp. TH Sub-cool heat exchanger LP gas (inlet) TH Sub-cool heat exchanger LP gas (outlet) TH Sub-cool heat exchanger HP liquid (outlet) TH	Outdoor temp. TH	Heat sink temp. TH

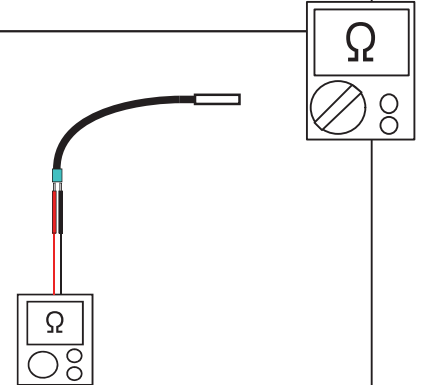

SERVICE PARTS INFORMATION 6

Discharge Pressure Sensor Suction Pressure Sensor

1. Discharge Pressure Sensor

Check Point : Check Voltage from Main PCB

- With the connector connected to the PCB, measure the voltage between CN91:3-4 of the Main PCB.

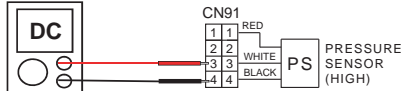

- Characteristics of pressure sensor

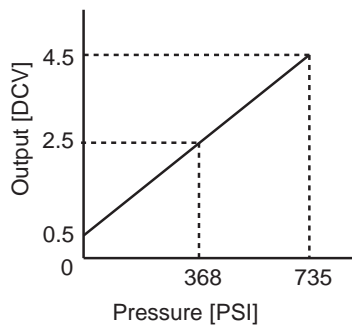

2. Suction Pressure Sensor

Check Point : Check Voltage from Main PCB

- With the connector connected to the PCB, measure the voltage between CN92:2-3 of the Main PCB.

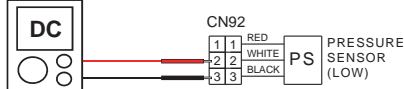

- Characteristics of pressure sensor

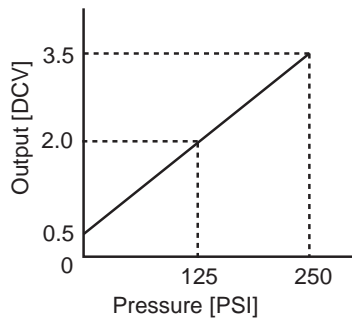

SERVICE PARTS INFORMATION 7

Outdoor Fan Motor

Check Point 1 : Check rotation of Fan

- Rotate the fan by hand when operation is off.
(Check if fan is caught, dropped off or locked motor)
- >>If Fan or Bearing is abnormal, replace it.**

Check Point 2 : Check resistance of Outdoor fan motor

- Refer to below. Circuit-test "Vm" and "GND" terminal.
(Vm: DC voltage, GND: Earth terminal)
- >>If they are short-circuited (below 300 kΩ), replace Outdoor fan motor and Main PCB.**

Pin number (wire color)	Terminal function (symbol)
1 (Red)	DC voltage (Vm)
2	No function
3	No function
4 (Black)	Earth terminal (GND)
5 (White)	Control voltage (Vcc)
6 (Yellow)	Speed comand (Vsp)
7 (Brown)	Feed back (FG)

SERVICE PARTS INFORMATION 8

Active Filter Module

Check Point 1 : Check Open or Short-circuit and Diode

- Remove connector, check the open or short-circuit and the diode in the module

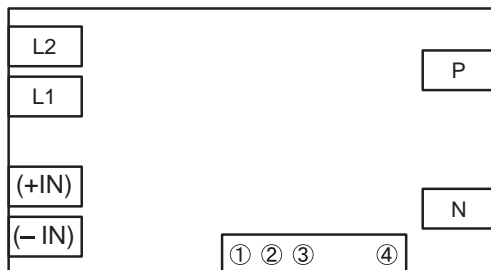

Check the open or short-circuit

Terminal		Resistance value
Tester(+)	Tester(-)	
(+IN)	(-IN)	360kΩ ± 20%
(-IN)	N	0 Ω
P	(+IN)	900kΩ ± 20%
L1	L2	2.03MΩ±20% / 4.83MΩ±20% (Ref. value 1) (Ref. value 2)
P	N	540kΩ ± 20%
L1,L2	Control Box	∞ Ω
L2	N	1.69MΩ±20% / 1.23MΩ±20% (Ref. value 1) (Ref. value 2)

Check the diode

Terminal		Resistance value
Tester(+)	Tester(-)	
L2	P	1.12MΩ±20% / 504kΩ±20% (Ref. value 1) (Ref. value 2)
P	L2	2.23MΩ±20% / 503kΩ±20% (Ref. value 1) (Ref. value 2)

Ref. value 1
 Specifications for Multimeter
 Manufacturer : FLUKE
 Model name : FLUKE11
 Power source : DC9V.

Ref. value 2
 Specifications for Multimeter
 Manufacturer : Sanwa
 Model name : PM3
 Power source : DC3V.

► **If it is abnormal,replace ACTIVE FILTER MODULE**

Check Point 2 : Check the Output DC voltage (between P and N)

- Check the Output DC voltage (between P and N) of compressor stopping and operating.
 - >> If the output voltage of compressor operating is less than the output voltage of compressor stopping, Active Filter Module is defective. >> **Replace Active Filter Module**

SERVICE PARTS INFORMATION 10
Diode Bridge (on the Inverter PCB)

Check Point 1: Check OPEN / SHORT of Diode Bridge

• Remove each terminal, and check open / short of the Diode Bridge.

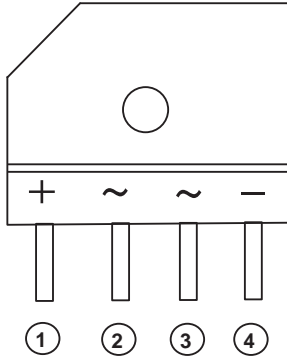

(+), (-) shows the terminal of the meter

Read wire		Resistance Value
① pin (-)	② Pin (+)	1MΩ greater
	③ Pin (+)	
④ pin (+)	② Pin (-)	
	③ Pin (-)	

▶ **If it is abnormal, replace Inverter PCB**