

## 3 - 5 TON PACKAGED GAS/ELECTRIC UNITS

14 SEER / UP TO 12.0 EER

UP TO 81% EFFICIENT

COOLING CAPACITY: 35,000 — 58,000 BTU/H

HEATING CAPACITY: 46,000 — 138,000 BTU/H



### ■ Contents

Nomenclature.....	2
Product Specifications.....	4
Expanded Cooling Data .....	13
Airflow Data .....	19
Crankcase Heater .....	27
Electrical Data .....	28
Dimensions .....	29
Wiring Diagrams .....	33
– for Models with DDC Controls .....	53
Accessories .....	54

### ■ Standard Features

- Patented tubular heat exchanger
- High-efficiency scroll compressor
- High and low-pressure switches
- Copper tube / aluminum fin coils
- Contactor with lugs
- High-capacity, steel-cased filter drier
- 24-volt terminal strip
- Convertible airflow orientation
- Easy to service
- Built-in filter rack with standard 2" filters
- Bottom utility entry
- Complies with California Low NOx emissions standards
- 3-5 Tons with single speed blower motor units meet the performance specified in Table 6.8.1-1 of ASHRAE Standard 90.1-2013
- AHRI Certified; ETL Listed

### ■ Cabinet Features

- Heavy-gauge, galvanized-steel cabinet with UV-resistant powder-paint finish
- Full Perimeter Rail
- Sloped drain pan



\* Complete warranty details available from your local distributor or manufacturer's representative or at [www.daikincomfort.com](http://www.daikincomfort.com).

		D	S	G	060	090	3	V	*	*	*	A	*
		1	2	3	4,5,6	7,8,9	10	11	12	13	14	15	16
													<b>REVISION LEVELS</b>
													Major & Minor
													<b>FACTORY-INSTALLED OPTIONS</b>
<b>BRAND</b>													
D Daikin													X No Options
<b>CONFIGURATION</b>													A Non-powered convenience outlet
C Standard Efficiency (6 - 25 Tons)													B Powered convenience outlet
S Standard Efficiency (3 - 5 Tons)													C Low-ambient kit
T High Efficiency (3 - 5 Tons)													D Return air smoke detector
<b>APPLICATION</b>													E Supply air smoke detector
C Cooling <sup>1</sup>													F Non-powered convenience outlet; Low-ambient kit
G Gas Heat													G Non-powered convenience outlet; Return air smoke detector
H Heat Pump <sup>1</sup>													H Non-powered convenience outlet; Supply air smoke detector
<b>NOMINAL COOLING CAPACITY</b>													J Non-powered convenience outlet; Return & Supply air smoke detectors
036	3 Tons	102	8½ Tons	300	25 Tons								K Non-powered convenience outlet; Low-ambient kit; Supply air smoke detector
048	4 Tons	120	10 Tons								L Non-powered convenience outlet; Low-ambient kit		
060	5 Tons	150	12½ tons								Return & Supply air smoke detectors		
072	6 Tons	180	15 Tons								M Powered convenience outlet; Low-ambient kit		
090	7½ Tons	240	20 Tons								N Powered convenience outlet; Return air smoke detector		
<b>NOMINAL HEATING CAPACITY</b>													O Powered convenience outlet; Return & Supply air smoke detectors
Gas/Electric		A/C H/P		Factory-Installed		Electric Heat							P Powered convenience outlet; Supply air smoke detector
045	45,000 BTU/h	XXX	No Heat								Q Powered convenience outlet; Low-ambient kit; Return air smoke detector		
090	90,000 BTU/h	010	10 kW	030	30 kW						R Powered convenience outlet; Low-ambient kit; Supply air smoke detector		
115	115,000 BTU/h	015	15 kW	031	30 kW						T Powered convenience outlet; Low-ambient kit; Return & Supply air smoke detectors		
140	140,000 BTU/h	016	15 kW	045	45 kW						U Non-powered convenience outlet; Low-ambient kit; Return air smoke detector		
210	210,000 BTU/h	018	18 kW	046	45 kW						V Low-ambient kit; Return air smoke detector		
350	350,000 BTU/h	020	20 kW	060	60 kW						W Low-ambient kit; Supply air smoke detector		
400	400,000 BTU/h	025	25 kW								Y Low-ambient kit; Return & Supply air smoke detectors		
See product specifications for heat size(s) available for each capacity.													Z Return & Supply air smoke detectors
<b>VOLTAGE</b>													<b>FACTORY-INSTALLED OPTIONS</b>
1	208-230/1/60 (DS* & DT* 3-5 Tons models only)				4	460/3/60							X Standard Aluminized Heat Exchanger
3	208-230/3/60				7	575/3/60							S Stainless-Steel Heat Exchanger
<b>SUPPLY FAN/DRIVE TYPE/MOTOR</b>													D Hinged Panels
B Belt Drive (3-5 Tons single speed models only)													K Stainless-Steel Heat Exchanger; Hinged Panels
D Direct Drive (3-5 Tons single speed models only)													B Phase Monitor
H High Static (3-5 Tons single-speed Belt Drive models only)													J Stainless Steel Heat Exchanger; Phase Monitor
V Two-Speed Belt Drive (6-25 Tons only)													M Hinged Panel; Phase Monitor
W High Static (6-25 Tons two-speed Belt Drive models only)													L Stainless-Steel Heat Exchanger; Hinged Panels; Phase Monitor
<b>FACTORY-INSTALLED OPTIONS</b>													
A Ultra Low-Leak Downflow Economizer													
B DDC-BACnet protocol													
F Ultra Low-Leak Downflow Economizer; DDC-BACnet protocol													
H Disconnect Switch (non-fused)													
J Ultra Low-Leak Downflow Economizer; Disconnect Switch (non-fused)													
M Disconnect Switch (non-fused); DDC-BACnet protocol													
R Ultra Low-Leak Downflow Economizer; DDC-BACnet protocol; Disconnect Switch (non-fused)													
V Low-Leak Downflow Economizer													
W Low-Leak Downflow Economizer Disconnect Switch (non-fused)													
X No Options													

**Note: Not all options available for all products.**

<sup>1</sup>X= No Options in character 13th

**FACTORY-INSTALLED OPTIONS**

- Stainless-Steel Heat Exchanger (Gas only units): A tubular heat exchanger made of 409-type stainless steel is installed in the unit.
- Low-Ambient Kit: Allows for cooling operation at lower outdoor temperatures. On the 3- to 6-ton units, cooling operation is extended from 60°F ambient temperature to 35°F outside air temperature. On 7½ -20 ton units, cooling operation is extended from 35°F ambient temperature to 0°F outside air temperature. For 25 ton units, cooling operation is extended from 24°F ambient temperature to 0°F outside air temperature.
- Economizers (Downflow): Based on air conditions, can provide outside air to cool the space.
- Electric Heat Kits (heat pump and cooling units only): Available in all voltage options.
- Non-powered Convenience Outlet: A 120V, 15A, GFCI outlet makes it easier for technicians to service the unit once an electrician runs power to the outlet.
- Powered Convenience Outlet: A 120V, 15A, GFCI outlet powered with a transformer built into the unit. When a factory-installed powered convenience outlet is installed in the equipment, the unit MCA (Min. Circuit Ampacity) will increase by 7.2A/6.5A for 208/230V units, increase by 3.3A for 460V units, and by 2.6A for 575V units. The MOP (Max. Overcurrent Protection) device must be sized accordingly.
- Disconnect Switch (non-fused; 3-phase units only): A disconnect switch is installed in the unit and factory wiring will be complete from the switch to the unit. Please note that for air conditioning and heat pump models, the appropriate electric heat kit must be ordered to be factory-installed along with the disconnect switch (non-fused) when it is ordered. Please note that for models with a powered convenience outlet option and a disconnect switch (non-fused) option, the power to the powered convenience outlet will be shut off when the disconnect switch (non-fused) is in the off position.
- Return Air and/or Supply Air Smoke Detectors: Return air and/or supply air smoke detectors are installed in the unit.
- Hinged Access Panels: Allows access to unit's major components. Combined with latches for easy access to control box, compressor, filters and blower motor. Available on all units.
- Two-speed indoor fan blower models are available on 6, 7½, 8½, 10, 12½, 15, 20 & 25 ton units. Section 6.4.3.10.b of ASHRAE Standard 90.1-2010 and Section 6.5.3.2.1.a of ASHRAE Standard 90.1-2013 require a minimum of two fan speeds. Section 140.4(m)1 of California Energy Commission Title 24 2013 contains a similar provision. When the units with the two-speed indoor fan blowers operate on a call for the first stage of cooling, the fan operates at low speed, which is 66% of full speed. When the units operate on a call for the second stage of cooling, the fan operates at full speed. In heating operation, the fan operates at full speed. During ventilation operation, the fan operates at low speed.
- Return Air and/or Supply Air Smoke Detectors: Return air and/or supply air smoke detectors are installed in the unit.
- Hinged Access Panels: Allows access to unit's major components. Combined with latches for easy access to control box, compressor, filters and blower motor. Available on all models.
- Phase Monitor: Phase monitor (3 phase only), available for 3 - 25 ton DS, DC and DT series models. Phase monitor shall provide protection for motors and compressors against problems caused by phase loss, phase reversal and phase unbalance. Phase monitor is equipped with an LED that provides an ON or FAULT indicator.
- DDC Controller: DDC communicating controller, available for 3 - 25 ton DS, DC and DT series models with on-board BACnet® communication interface.

	DSG036 0451D***A*	DSG036 0453D***A*	DSG036 0453B***A*	DSG036 0454B***A*
<b>COOLING CAPACITY</b>				
Total BTU/h	36,000	36,000	35,000	35,000
Sensible BTU/h	26,640	26,640	25,600	25,600
SEER / EER	14 / 12	14 / 12	14 / 12	14 / 12
Decibels	78	78	78	78
AHRI Reference #s	9967131	9967134	9952114	9952120
<b>HEATING CAPACITY</b>				
High Input / Output BTU/h	46 / 36.8	46 / 36.8	46 / 36.8	46 / 36.8
Low Input / Output BTU/h	----	----	----	----
Thermal Efficiency (T.E.)	----	80	80	80
Annual Fuel Utilization Efficiency (AFUE)	81	----	----	----
Temperature Rise Range (°F) Hi / Low	25-55	25-55	25-55	25-55
No. of Burners	2	2	2	2
<b>EVAPORATOR MOTOR / COIL</b>				
Motor Type	Direct Drive	Direct Drive	Belt Drive	Belt Drive
Indoor Nominal CFM	1,250	1,250	1,200	1,200
Motor Speed Tap (Cooling)	Low Speed	Low Speed	---	---
Indoor Motor FLA (Cooling)	2.46	2.46	3.4	1.7
Horsepower - RPM	1/3 - 910	1/3 - 910	1.0 - 1725	1.0 - 1725
Piston Size (Cooling)	0.070	0.070	0.070	0.070
Filter Size (")	(4) 14" x 20" x 2"	(4) 14" x 20" x 2"	(4) 14" x 20" x 2"	(4) 14" x 20" x 2"
Drain Size (NPT)	¾"	¾"	¾"	¾"
R-410A Refrigerant Charge Cir #1 (oz.)	105	105	105	105
Evaporator Coil Face Area (ft <sup>2</sup> )	7.0	7.0	7.0	7.0
Rows Deep / Fins per Inch	4 / 16	4 / 16	4 / 16	4 / 16
<b>BELT DRIVE EVAP FAN DATA</b>				
# of Wheels (D x W)	----	----	1 (11" x 10")	1 (11" x 10")
Motor Sheave	----	----	1VL34 X ¾"	1VL34 X ¾"
Blower Sheave / Belt	----	----	AK61 x 1 / AX51	AK61 x 1 / AX51
<b>CONDENSER FAN / COIL</b>				
Quantity of Condenser Fan Motors	1	1	1	1
Horsepower - RPM	¼ - 1,075	¼ - 1,075	¼ - 1,075	¼ - 1,050
Fan Diameter / # Fan Blades	22 / 4	22 / 4	22/4	22/4
Outdoor Nominal CFM	3,800	3,800	3,800	3,800
Face Area (ft <sup>2</sup> )	17.1	17.1	17.1	17.1
Rows Deep/ Fins per Inch	1 / 24	1 / 24	1 / 24	1 / 24
<b>COMPRESSOR</b>				
Quantity / Type/ Stage	1 / Scroll / Single	1 / Scroll / Single	1 / Scroll / Single	1 / Scroll / Single
Compressor RLA / LRA	16.7 / 79.0	10.4 / 73.0	10.4 / 73.0	5.8 / 38.0
<b>ELECTRICAL DATA</b>				
Voltage-Phase-Frequency	208/230-1-60	208/230-3-60	208/230-3-60	460-3-60
Indoor Blower HP / FLA	1/3 / 2.46	1/3 / 2.46	1 / 3.4	1 / 1.7
Max. External Static	0.5"	0.5"	1.0"	1.0"
Outdoor Fan HP / FLA	¼ / 1.4	¼ / 1.4	¼ / 1.4	¼ / 0.7
Min. Circuit Ampacity <sup>1</sup>	24.7 / 24.7	16.9 / 16.9	17.9 / 17.9	9.6
Max. Overcurrent Protection (amps) <sup>2</sup>	40 / 40	25 / 25	25 / 25	15
Power Supply Conduit Hole	1.125"	1.125"	1.125"	1.125"
Low-Voltage Conduit Hole	½"	½"	½"	½"
<b>OPERATING WEIGHT (LBS)</b>				
	565	565	565	565
<b>SHIP WEIGHT (LBS)</b>				
	590	590	590	590

<sup>1</sup> Wire size should be determined in accordance with National Electrical Codes. Extensive wire runs will require larger wire sizes.

<sup>2</sup> May use fuses or HACR-type circuit breakers of the same size as noted.

**NOTES**

- Always check the S&R plate for electrical data on the unit being installed.

	DSG036 0703B***A*	DSG036 0704B***A*
<b>COOLING CAPACITY</b>		
Total BTU/h	35,000	35,000
Sensible BTU/h	25,600	25,600
SEER / EER	14 / 12	14 / 12
Decibels	78	78
AHRI Reference #s	9952114	9952120
<b>HEATING CAPACITY</b>		
High Input / Output BTU/h	69 / 55	69 / 55
Low Input / Output BTU/h	51 / 41	51 / 41
Thermal Efficiency (T.E.)	80	80
Annual Fuel Utilization Efficiency (AFUE)	----	----
Temperature Rise Range (°F) Hi / Low	25-55 / 15-45	25-55 / 15-45
No. of Burners	3	3
<b>EVAPORATOR MOTOR / COIL</b>		
Motor Type	Belt Drive	Belt Drive
Indoor Nominal CFM	1,200	1,200
Motor Speed Tap (Cooling)	---	---
Indoor Motor FLA (Cooling)	3.4	1.7
Horsepower - RPM	1.0 - 1725	1.0 - 1,725
Piston Size (Cooling)	0.070	0.070
Filter Size (")	(4) 14" x 20" x 2"	(4) 14" x 20" x 2"
Drain Size (NPT)	¾"	¾"
R-410A Refrigerant Charge Cir #1 (oz.)	105	105
Evaporator Coil Face Area (ft <sup>2</sup> )	7.0	7.0
Rows Deep / Fins per Inch	4 / 16	4 / 16
<b>BELT DRIVE EVAP FAN DATA</b>		
# of Wheels (D x W)	1 (11" x 10")	1 (11" x 10")
Motor Sheave	1VL34 x ¾"	1VL34 x ¾"
Blower Sheave / Belt	AK61 x 1 / AX51	AK61 x 1 / AX51
<b>CONDENSER FAN / COIL</b>		
Quantity of Condenser Fan Motors	1	1
Horsepower - RPM	¼ - 1,075	¼ - 1,050
Fan Diameter / # Fan Blades	22/4	22 / 4
Outdoor Nominal CFM	3,800	3,800
Face Area (ft <sup>2</sup> )	17.1	17.1
Rows Deep/ Fins per Inch	1 / 24	1 / 24
<b>COMPRESSOR</b>		
Quantity / Type/ Stage	1 / Scroll/Single	1 / Scroll/Single
Compressor RLA / LRA	10.4 / 73.0	5.8 / 38.0
<b>ELECTRICAL DATA</b>		
Voltage-Phase-Frequency	208/230-3-60	460-3-60
Indoor Blower HP / FLA	1 / 3.4	1 / 1.7
Max. External Static	1.0"	1.0"
Outdoor Fan HP / FLA	¼ / 1.4	¼ / 0.7
Min. Circuit Ampacity <sup>1</sup>	17.9	10
Max. Overcurrent Protection (amps) <sup>2</sup>	25	15
Power Supply Conduit Hole	1.125	1.125
Low-Voltage Conduit Hole	½"	½"
<b>OPERATING WEIGHT (LBS)</b>		
<b>SHIP WEIGHT (LBS)</b>		
	570	570
	595	595

<sup>1</sup> Wire size should be determined in accordance with National Electrical Codes. Extensive wire runs will require larger wire sizes.

<sup>2</sup> May use fuses or HACR-type circuit breakers of the same size as noted.

**NOTES**

- Always check the S&R plate for electrical data on the unit being installed.

PRODUCT SPECIFICATIONS — 3 TONS (CONT.)

	DSG036 0901D***A*	DSG036 0903D***A*	DSG036 0903B***A*	DSG036 0904B***A*	DSG036 0907B***A*
<b>COOLING CAPACITY</b>					
Total BTU/h	36,000	36,000	35,000	35,000	35,000
Sensible BTU/h	26,640	26,640	25,600	25,600	25,600
SEER / EER	14 / 12	14 / 12	14 / 12	14 / 12	14 / 12
Decibels	78	78	78	78	78
AHRI Reference #s	9967131	9967134	9952114	9952120	9952126
<b>HEATING CAPACITY</b>					
High Input / Output BTU/h	92 / 75	92 / 74	92 / 74	92 / 74	92 / 74
Low Input / Output BTU/h	69 / 56	69 / 55	69 / 55	69 / 55	69 / 55
Thermal Efficiency (T.E.)	----	80	80	80	80
Annual Fuel Utilization Efficiency (AFUE)	81	----	----	----	----
Temperature Rise Range (°F) Hi / Low	30-60 / 20-50	40-70 / 30-60	40-70 / 30-60	25-55	25-55
No. of Burners	4	4	4	4	4
<b>EVAPORATOR MOTOR / COIL</b>					
Motor Type	Direct Drive	Direct Drive	Belt Drive	Belt Drive	Belt Drive
Indoor Nominal CFM	1,250	1,250	1,200	1,200	1,200
Motor Speed Tap (Cooling)	LOW	LOW	---	---	---
Indoor Motor FLA (Cooling)	2.46	2.46	3.4	1.7	2.3
Horsepower - RPM	½ - 910	½ - 910	1.0 - 1725	1.0 - 1,725	1.5 - 1,725
Piston Size (Cooling)	0.070	0.070	0.070	0.070	0.070
Filter Size (")	(4) 14" x 20" x 2"	(4) 14" x 20" x 2"	(4) 14" x 20" x 2"	(4) 14" x 20" x 2"	(4) 14" x 20" x 2"
Drain Size (NPT)	¾"	¾"	¾"	¾"	¾"
R-410A Refrigerant Charge Cir #1 (oz.)	105	105	105	105	105
Evaporator Coil Face Area (ft²)	7.0	7.0	7.0	7.0	7.0
Rows Deep / Fins per Inch	4 / 16	4 / 16	4 / 16	4 / 16	4 / 16
<b>BELT DRIVE EVAP FAN DATA</b>					
# of Wheels (D x W)	----	----	1 (11" x 10")	1 (11" x 10")	1 (11" x 10")
Motor Sheave	----	----	1VL34 x ¾"	1VL34 x ¾"	1VL34 x ¾"
Blower Sheave / Belt	----	----	AK61 x 1 / AX51	AK61 x 1 / AX51	AK61 x 1 / AX51
<b>CONDENSER FAN / COIL</b>					
Quantity of Condenser Fan Motors	1	1	1	1	1
Horsepower - RPM	¼ - 1,075	¼ - 1,075	¼ - 1,075	¼ - 1,050	¼ - 1,050
Fan Diameter / # Fan Blades	22 / 4	22 / 4	22/4	22 / 4	22 / 4
Outdoor Nominal CFM	3,800	3,800	3,800	3,800	3,800
Face Area (ft²)	17.1	17.1	17.1	17.1	17.1
Rows Deep/ Fins per Inch	1 / 24	1 / 24	1 / 24	1 / 24	1 / 24
<b>COMPRESSOR</b>					
Quantity / Type/ Stage	1 / Scroll / Single	1 / Scroll / Single	1 / Scroll / Single	1 / Scroll / Single	1 / Scroll / Single
Compressor RLA / LRA	16.7 / 79.0	10.4 / 73.0	10.4 / 73.0	5.8 / 38.0	3.8 / 36.5
<b>ELECTRICAL DATA</b>					
Voltage-Phase-Frequency	208/230-1-60	208/230-3-60	208/230-3-60	460-3-60	575-3-60
Indoor Blower HP / FLA	1/3 / 2.46	1/3 / 2.46	1 / 3.4	1 / 1.7	1.5 / 2.3
Max. External Static	0.5"	0.5"	1.0"	1.0"	1.0"
Outdoor Fan HP / FLA	¼ / 1.4	¼ / 1.4	¼ / 1.4	¼ / 0.7	¼ / 0.55
Min. Circuit Ampacity <sup>1</sup>	24.7 / 24.7	16.9 / 16.9	16.9 / 16.9	9.6	7.6
Max. Overcurrent Protection (amps) <sup>2</sup>	40 / 40	25 / 25	25 / 25	15	15
Power Supply Conduit Hole	1.125"	1.125"	1.125"	1.125"	1.125"
Low-Voltage Conduit Hole	½"	½"	½"	½"	½"
<b>OPERATING WEIGHT (LBS)</b>					
	575	575	575	575	575
<b>SHIP WEIGHT (LBS)</b>					
	600	600	600	600	600

<sup>1</sup> Wire size should be determined in accordance with National Electrical Codes. Extensive wire runs will require larger wire sizes.

<sup>2</sup> May use fuses or HACR-type circuit breakers of the same size as noted.

**NOTES**

- Always check the S&R plate for electrical data on the unit being installed.

	DSG048 0703B***A*	DSG048 0704B***A*
<b>COOLING CAPACITY</b>		
Total BTU/h	47,000	47,000
Sensible BTU/h	35,000	35,000
SEER / EER	14 / 11.8	14 / 11.8
Decibels	78	78
AHRI Reference #s	9952115	9952121
<b>HEATING CAPACITY</b>		
High Input / Output BTU/h	69 / 55	69 / 55
Low Input / Output BTU/h	51 / 41	51 / 41
Thermal Efficiency (T.E.)	80	80
Annual Fuel Utilization Efficiency (AFUE)	----	----
Temperature Rise Range (°F) Hi / Low	20-50 / 10-40	20-50 / 10-40
No. of Burners	3	3
<b>EVAPORATOR MOTOR / COIL</b>		
Motor Type	Belt Drive	Belt Drive
Indoor Nominal CFM	1,600	1,600
Motor Speed Tap (Cooling)	---	--
Indoor Motor FLA (Cooling)	3.4	1.7
Horsepower - RPM	1.0 / 1,725	1.0 / 1,725
Piston Size (Cooling)	0.074	0.074
Filter Size (")	(4)14 x 20 x 2	(4)14" x 20" x 2"
Drain Size (NPT)	¾"	¾"
R-410A Refrigerant Charge Cir #1 (oz.)	111	111
Evaporator Coil Face Area (ft <sup>2</sup> )	7.8	7.8
Rows Deep / Fins per Inch	4 / 16	4 / 16
<b>BELT DRIVE EVAP FAN DATA</b>		
# of Wheels (D x W)	(1) 11 x 10	(1) 11 x 10
Motor Sheave	VL40 X ¾"	VL40 X ¾"
Blower Sheave / Belt	AK66 X 1 / AX52	AK66 X 1 / AX52
<b>CONDENSER FAN / COIL</b>		
Quantity of Condenser Fan Motors	1	1
Horsepower - RPM	¼ - 1,075	¼ - 1050
Fan Diameter / # Fan Blades	22 / 4	22 / 4
Outdoor Nominal CFM	3,800	3,800
Face Area (ft <sup>2</sup> )	12.5	12.5
Rows Deep / Fins per Inch	2 / 27	2 / 27
<b>COMPRESSOR</b>		
Quantity / Type / Stage	1 / Scroll / Single	1 / Scroll / Single
Compressor RLA / LRA	13.1 / 83.1	6.1 / 41
<b>ELECTRICAL DATA</b>		
Voltage-Phase-Frequency	208/230-3-60	460-3-60
Indoor Blower HP / FLA	1.0 / 3.4	1.0 / 1.7
Max. External Static	1.0"	1.0"
Outdoor Fan HP / FLA	¼ / 1.4	¼ / 0.7
Min. Circuit Ampacity <sup>1</sup>	21.2	10.0
Max. Overcurrent Protection (amps) <sup>2</sup>	30	15
Power Supply Conduit Hole	1.125	1.125
Low-Voltage Conduit Hole	½"	½"
<b>OPERATING WEIGHT (LBS)</b>		
	605	605
<b>SHIP WEIGHT (LBS)</b>		
	630	630

<sup>1</sup> Wire size should be determined in accordance with National Electrical Codes. Extensive wire runs will require larger wire sizes.

<sup>2</sup> May use fuses or HACR-type circuit breakers of the same size as noted.

**NOTES**

- Always check the S&R plate for electrical data on the unit being installed.

PRODUCT SPECIFICATIONS — 4 TONS (CONT.)

	DSG048 0901D***A*	DSG048 0903D***A*	DSG048 0903B***A*	DSG048 0904B***A*
<b>COOLING CAPACITY</b>				
Total BTU/h	48,000	48,000	47,000	47,000
Sensible BTU/h	35,520	35,520	35,000	35,000
SEER / EER	14 / 12	14 / 12	14 / 11.8	14 / 11.8
Decibels	78	78	78	78
AHRI Reference #s	9967132	9967135	9952115	9952121
<b>HEATING CAPACITY</b>				
High Input / Output BTU/h	92 / 75	92 / 74	92 / 74	92 / 74
Low Input / Output BTU/h	69 / 56	69 / 55	69 / 55	69 / 55
Thermal Efficiency (T.E.)	----	80	80	80
Annual Fuel Utilization Efficiency (AFUE)	81	----	----	----
Temperature Rise Range (°F) Hi / Low	25-50/ 15-45	30-60 / 15-45	30-60 / 15-45	30-60 / 15-45
No. of Burners	4	4	4	4
<b>EVAPORATOR MOTOR / COIL</b>				
Motor Type	Direct Drive	Direct Drive	Belt Drive	Belt Drive
Indoor Nominal CFM	1,600	1,600	1,600	1,600
Motor Speed Tap (Cooling)	LOW	LOW	---	--
Indoor Motor FLA (Cooling)	2.80	2.80	3.4	1.7
Horsepower - RPM	¾ -1,025	¾ -1,025	1.0 / 1,725	1.0 / 1,725
Piston Size (Cooling)	0.076	0.076	0.074	0.074
Filter Size (Qty)	(4) 14" x 20" x 2"	(4) 14" x 20" x 2"	(4)14 x 20 x 2	(4)14" x 20" x 2"
Drain Size (NPT)	¾"	¾"	¾"	¾"
R-410A Refrigerant Charge Cir #1 (oz.)	110	110	111	111
Evaporator Coil Face Area (ft²)	7.8	7.8	7.8	7.8
Rows Deep / Fins per Inch	4 / 16	4 / 16	4 / 16	4 / 16
<b>BELT DRIVE EVAP FAN DATA</b>				
# of Wheels (D x W)	----	----	(1) 11 x 10	(1) 11 x 10
Motor Sheave	----	----	VL40 X ¾"	VL40 X ¾"
Blower Sheave / Belt	----	----	AK66 X 1/ AX52	AK66 X 1/ AX52
<b>CONDENSER FAN / COIL</b>				
Quantity of Condenser Fan Motors	1	1	1	1
Horsepower - RPM	¾ - 1,075	¾ - 1,075	¾ - 1,075	¾ - 1050
Fan Diameter / # Fan Blades	22 / 4	22 / 4	22 / 4	22 / 4
Outdoor Nominal CFM	3,800	3,800	3,800	3,800
Face Area (ft²)	12.5	12.5	12.5	12.5
Rows Deep/ Fins per Inch	2 / 27	2 / 27	2 / 27	2 / 27
<b>COMPRESSOR</b>				
Quantity / Type/ Stage	1 / Scroll / Single	1 / Scroll / Single	1 / Scroll / Single	1 / Scroll / Single
Compressor RLA / LRA	19.9 / 109	13.1 / 83.1	13.1 / 83.1	6.1 / 41
<b>ELECTRICAL DATA</b>				
Voltage-Phase-Frequency	208/230-1-60	208/230-3-60	208/230-3-60	460-3-60
Indoor Blower HP / FLA	¾ / 2.8	¾ / 2.8	1.0 / 3.4	1.0 / 1.7
Max. External Static	0.5"	0.5"	1.0"	1.0"
Outdoor Fan HP / FLA	1.40	1.40	1.40	0.70
Min. Circuit Ampacity <sup>1</sup>	29 / 29	20.6 / 20.6	21.2 / 21.2	10
Max. Overcurrent Protection (amps) <sup>2</sup>	45 / 45	30 / 30	30 / 30	15
Power Supply Conduit Hole	1.125"	1.125"	1.125"	1.125"
Low-Voltage Conduit Hole	½"	½"	½"	½"
<b>OPERATING WEIGHT (LBS)</b>				
	610	610	610	610
<b>SHIP WEIGHT (LBS)</b>				
	635	635	635	635

<sup>1</sup> Wire size should be determined in accordance with National Electrical Codes. Extensive wire runs will require larger wire sizes.

<sup>2</sup> May use fuses or HACR-type circuit breakers of the same size as noted.

**NOTES**

- Always check the S&R plate for electrical data on the unit being installed.



	DSG048 1151D***A*	DSG048 1153D***A*	DSG048 1153B***A*	DSG048 1154B***A*	DSG048 1157B***A*
<b>COOLING CAPACITY</b>					
Total BTU/h	48,000	48,000	47,000	47,000	47,000
Sensible BTU/h	35,520	35,520	35,000	35,000	35,000
SEER / EER	14 / 12	14 / 12	14 / 11.8	14 / 11.8	14 / 11.8
Decibels	78	78	78	78	78
AHRI Reference #s	9967132	9967135	9952115	9952121	9952127
<b>HEATING CAPACITY</b>					
High Input / Output BTU/h	115 / 93	115 / 92	115 / 92	115 / 92	115 / 92
Low Input / Output BTU/h	86 / 70	89 / 69	89 / 69	89 / 69	89 / 69
Thermal Efficiency (T.E.)	----	80	80	80	80
Annual Fuel Utilization Efficiency (AFUE)	81	----	----	----	----
Temperature Rise Range (°F) Hi / Low	40-70 / 25-55	40-70 / 25-55	40-70 / 25-55	40-70 / 25-55	40-70 / 25-55
No. of Burners	5	5	5	5	5
<b>EVAPORATOR MOTOR / COIL</b>					
Motor Type	Direct Drive	Direct Drive	Belt Drive	Belt Drive	Belt Drive
Indoor Nominal CFM	1,600	1,600	1,600	1,600	1,600
Motor Speed Tap (Cooling)	LOW	LOW	--	--	--
Indoor Motor FLA (Cooling)	2.80	2.80	3.4	1.7	2.3
Horsepower - RPM	¾ -1,025	¾ -1,025	1.0 / 1,725	1.0 / 1,725	1.5 / 1,725
Piston Size (Cooling)	0.076	0.076	0.074	0.074	0.074
Filter Size (Qty)	(4) 14" x 20" x 2"	(4) 14" x 20" x 2"	(4) 14" x 20" x 2"	(4) 14" x 20" x 2"	(4) 14" x 20" x 2"
Drain Size (NPT)	¾"	¾"	¾"	¾"	¾"
R-410A Refrigerant Charge Cir #1 (oz.)	110	110	111	111	111
Evaporator Coil Face Area (ft²)	7.8	7.8	7.8	7.8	7.8
Rows Deep / Fins per Inch	4 / 16	4 / 16	4 / 16	4 / 16	4 / 16
<b>BELT DRIVE EVAP FAN DATA</b>					
# of Wheels (D x W)	----	----	(1) 11 x 10	(1) 11 x 10	(1) 11 x 10
Motor Sheave	----	----	VL40 X ¾"	VL40 X ¾"	VL40 X ¾"
Blower Sheave / Belt	----	----	AK66 X 1/ AX52	AK66 X 1/ AX52	AK66 X 1/ AX52
<b>CONDENSER FAN / COIL</b>					
Quantity of Condenser Fan Motors	1	1	1	1	1
Horsepower - RPM	¼ - 1,075	¼ - 1,075	¼ - 1,075	¼ - 1050	¼ - 1050
Fan Diameter / # Fan Blades	22 / 4	22 / 4	22 / 4	22 / 4	22 / 4
Outdoor Nominal CFM	3,800	3,800	3,800	3,800	3,800
Face Area (ft²)	12.5	12.5	12.5	12.5	12.5
Rows Deep/ Fins per Inch	2 / 27	2 / 27	2 / 27	2 / 27	2 / 27
<b>COMPRESSOR</b>					
Quantity / Type/ Stage	1 / Scroll / Single	1 / Scroll / Single	1 / Scroll / Single	1 / Scroll / Single	1 / Scroll / Single
Compressor RLA / LRA	19.9 / 109	13.1 / 83.1	13.1 / 83.1	6.1 / 41.0	4.4 / 33.0
<b>ELECTRICAL DATA</b>					
Voltage-Phase-Frequency	208/230-1-60	208/230-3-60	208/230-3-60	460-3-60	575-3-60
Indoor Blower HP / FLA	¾ / 2.8	¾ / 2.8	1.0 / 3.4	1.0 / 1.7	1.5 / 2.3
Max. External Static	0.5"	0.5"	1.0"	1.0"	1.0"
Outdoor Fan HP / FLA	1.40	1.40	1.40	0.70	0.55
Min. Circuit Ampacity <sup>1</sup>	29 / 29	20.6 / 20.6	21.2 / 21.2	10	8.3
Max. Overcurrent Protection (amps) <sup>2</sup>	45 / 45	30 / 30	30 / 30	15	15
Power Supply Conduit Hole	1.125"	1.125"	1.125"	1.125"	1.125"
Low-Voltage Conduit Hole	½"	½"	½"	½"	½"
<b>OPERATING WEIGHT (LBS)</b>					
	615	615	615	615	615
<b>SHIP WEIGHT (LBS)</b>					
	640	640	640	640	640

<sup>1</sup> Wire size should be determined in accordance with National Electrical Codes. Extensive wire runs will require larger wire sizes.

<sup>2</sup> May use fuses or HACR-type circuit breakers of the same size as noted.

**NOTES**

- Always check the S&R plate for electrical data on the unit being installed.

	DSG060 0901D***A*	DSG060 0903D***A*	DSG060 0903B***A*	DSG060 0904B***A*
<b>COOLING CAPACITY</b>				
Total BTU/h	58,000	58,000	58,000	58,000
Sensible BTU/h	42,340	42,340	42,800	42,800
SEER / EER	14 / 11.6	14 / 11.6	14 / 11.6	14 / 11.6
Decibels	78	78	78	78
AHRI Reference #s	9967133	9967136	9952116	9952122
<b>HEATING CAPACITY</b>				
High Input / Output BTU/h	92 / 75	92 / 74	92 / 74	92 / 74
Low Input / Output BTU/h	69 / 56	69 / 55	69 / 55	69 / 55
Thermal Efficiency (T.E.)	----	80	80	80
Annual Fuel Utilization Efficiency (AFUE)	81	----	----	----
Temperature Rise Range (°F) Hi / Low	25-55/20-50	20-50/15-45	20-50 / 15-45	20-50 / 15-45
No. of Burners	4	4	4	4
<b>EVAPORATOR MOTOR / COIL</b>				
Motor Type	Direct Drive	Direct Drive	Belt Drive	Belt Drive
Indoor Nominal CFM	1,800	1,800	1,800	1,800
Motor Speed Tap (Cooling)	T3	T3	----	----
Indoor Motor FLA (Cooling)	6.90	6.90	3.2	1.5
Horsepower - RPM	1 - 1,050	1 - 1,050	1 - 1760	1 - 1760
Piston Size (Cooling)	0.086	0.086	0.086	0.086
Filter Size (Qty)	(4) 14" x 20" x 2"	(4) 14" x 20" x 2"	(4) 14" x 20" x 2"	(4) 14" x 20" x 2"
Drain Size (NPT)	¾"	¾"	¾"	¾"
R-410A Refrigerant Charge Cir #1 (oz.)	100	100	100	100
Evaporator Coil Face Area (ft²)	7.8	7.8	7.8	7.8
Rows Deep / Fins per Inch	4 / 16	4 / 16	4 / 16	4 / 16
<b>BELT DRIVE EVAP FAN DATA</b>				
# of Wheels (D x W)	----	----	1 (11" x 10")	1 (11" x 10")
Motor Sheave	----	----	VL40 x ¾"	VL40 x ¾"
Blower Sheave / Belt	----	----	AK61 x 1/ AX52	AK61 x 1/ AX52
<b>CONDENSER FAN / COIL</b>				
Quantity of Condenser Fan Motors	1	1	1	1
Horsepower - RPM	¼ - 1,075	¼ - 1,075	¼ - 1,075	¼ - 1,075
Fan Diameter / # Fan Blades	22 / 4	22 / 4	22 / 4	22 / 4
Outdoor Nominal CFM	3,800	3,800	3,800	3,800
Face Area (ft²)	13	13	13	13
Rows Deep/ Fins per Inch	2 / 27	2 / 27	2 / 27	2 / 27
<b>COMPRESSOR</b>				
Quantity / Type/ Stage	1 / Scroll / Single	1 / Scroll / Single	1 / Scroll / Single	1 / Scroll / Single
Compressor RLA / LRA	26.4 / 134.0	16.0 / 110.0	16.0 / 110.0	7.8 / 52
<b>ELECTRICAL DATA</b>				
Voltage-Phase-Frequency	208/230-1-60	208/230-3-60	208/230-3-60	460-3-60
Indoor Blower HP / FLA	1.0 / 6.9	1.0 / 6.9	1.0 / 3.2	1.0 / 1.5
Max. External Static	0.9"	0.9"	1.0"	1.0"
Outdoor Fan HP / FLA	¼ / 1.40	¼ / 1.40	¼ / 1.40	¼ / 0.7
Min. Circuit Ampacity <sup>1</sup>	41.3 / 41.3	28.3 / 28.3	24.6 / 24.6	11.9
Max. Overcurrent Protection (amps) <sup>2</sup>	60 / 60	40 / 40	40 / 40	15
Power Supply Conduit Hole	1.125"	1.125"	1.125"	1.125"
Low-Voltage Conduit Hole	½"	½"	½"	½"
<b>OPERATING WEIGHT (LBS)</b>				
	610	610	610	610
<b>SHIP WEIGHT (LBS)</b>				
	635	635	635	635

<sup>1</sup> Wire size should be determined in accordance with National Electrical Codes. Extensive wire runs will require larger wire sizes.

<sup>2</sup> May use fuses or HACR-type circuit breakers of the same size as noted.

**NOTES**

- Always check the S&R plate for electrical data on the unit being installed.

	DSG060 1153B***A*	DSG060 1154B***A*
<b>COOLING CAPACITY</b>		
Total BTU/h	58,000	58,000
Sensible BTU/h	43,200	43,200
SEER / EER	14 / 11.6	14 / 11.6
Decibels	78	78
AHRI Reference #s	9952116	9952122
<b>HEATING CAPACITY</b>		
High Input / Output BTU/h	115 / 92	115 / 92
Low Input / Output BTU/h	86 / 69	86 / 69
Thermal Efficiency (T.E.)	80	80
Annual Fuel Utilization Efficiency (AFUE)	----	----
Temperature Rise Range (°F) Hi / Low	35-65 / 25-55	35-65 / 25-55
No. of Burners	5	5
<b>EVAPORATOR MOTOR / COIL</b>		
Motor Type	Belt Drive	Belt Drive
Indoor Nominal CFM	1,800	1,800
Motor Speed Tap (Cooling)	----	----
Indoor Motor FLA (Cooling)	3.2 - 3.0	1.5
Horsepower - RPM	1.0 - 1760	1.0 - 1760
Piston Size (Cooling)	0.086	0.086
Filter Size (")	(4) 14" x 20" x 2"	(4) 14" x 20" x 2"
Drain Size (NPT)	¾"	¾"
R-410A Refrigerant Charge Cir #1 (oz.)	100	100
Evaporator Coil Face Area (ft <sup>2</sup> )	7.8	7.8
Rows Deep / Fins per Inch	4 / 16	4 / 16
<b>BELT DRIVE EVAP FAN DATA</b>		
# of Wheels (D x W)	1 (11" x 10")	1 (11" x 10")
Motor Sheave	VL40 x ¾"	VL40 x ¾"
Blower Sheave / Belt	AK61 X 1/ AX52	AK61 X 1/ AX52
<b>CONDENSER FAN / COIL</b>		
Quantity of Condenser Fan Motors	1	1
Horsepower - RPM	¼ - 1,075	¼ - 1,075
Fan Diameter / # Fan Blades	22 / 4	22 / 4
Outdoor Nominal CFM	3,800	3,800
Face Area (ft <sup>2</sup> )	13	13
Rows Deep/ Fins per Inch	2 / 27	2 / 27
<b>COMPRESSOR</b>		
Quantity / Type/ Stage	1 / Scroll/Single	1 / Scroll/Single
Compressor RLA / LRA	16.0 / 110.0	7.8 / 52.0
<b>ELECTRICAL DATA</b>		
Voltage-Phase-Frequency	208/230-3-60	460-3-60
Indoor Blower HP / FLA	1.0 / 3.2	1.0 / 1.5
Max. External Static	1.0"	1.0"
Outdoor Fan HP / FLA	¾ / 1.40	¾ / 0.7
Min. Circuit Ampacity <sup>1</sup>	24.6	12
Max. Overcurrent Protection (amps) <sup>2</sup>	40	15
Power Supply Conduit Hole	1.125"	1.125"
Low-Voltage Conduit Hole	½"	½"
<b>OPERATING WEIGHT (LBS)</b>		
	619	619
<b>SHIP WEIGHT (LBS)</b>		
	644	644

<sup>1</sup> Wire size should be determined in accordance with National Electrical Codes. Extensive wire runs will require larger wire sizes.

<sup>2</sup> May use fuses or HACR-type circuit breakers of the same size as noted.

**NOTES**

- Always check the S&R plate for electrical data on the unit being installed.

	DSG060 1401D***A*	DSG060 1403D***A*	DSG060 1403B***A*	DSG060 1404B***A*	DSG060 1407B***A*
<b>COOLING CAPACITY</b>					
Total BTU/h	58,000	58,000	58,000	58,000	58,000
Sensible BTU/h	42,340	42,340	43,200	43,200	42,500
SEER / EER	14 / 11.6	14 / 11.6	14 / 11.6	14 / 11.6	14 / 11.6
Decibels	78	78	78	78	78
AHRI Reference #s	9967133	9967136	9952116	9952122	9952128
<b>HEATING CAPACITY</b>					
High Input / Output BTU/h	138 / 112	138 / 110	138 / 110	138 / 110	138 / 110
Low Input / Output BTU/h	104 / 84	103 / 83	103 / 83	103 / 83	103 / 83
Thermal Efficiency (T.E.)	----	80	80	80	80
Annual Fuel Utilization Efficiency (AFUE)	81	----	----	----	----
Temperature Rise Range (°F) Hi / Low	35-65 / 25 -55	35-65 / 25 -55	35-65 / 25-55	35-65 / 25-55	35-65 / 25-55
No. of Burners	6	6	6	6	6
<b>EVAPORATOR MOTOR / COIL</b>					
Motor Type	Direct Drive	Direct Drive	Belt Drive	Belt Drive	Belt Drive
Indoor Nominal CFM	1,800	1,800	1,800	1,800	1,800
Motor Speed Tap (Cooling)	T3	T3	----	----	----
Indoor Motor FLA (Cooling)	6.90	6.90	3.2	1.5	1.2
Horsepower - RPM	1.0 - 1,050	1.0 - 1,050	1.0 - 1760	1.0 - 1760	1.0 - 1760
Piston Size (Cooling)	0.086	0.086	0.086	0.086	0.086
Filter Size (")	(4) 14" x 20" x 2"	(4) 14" x 20" x 2"	(4) 14" x 20" x 2"	(4) 14" x 20" x 2"	(4) 14" x 20" x 2"
Drain Size (NPT)	¾"	¾"	¾"	¾"	¾"
R-410A Refrigerant Charge Cir #1 (oz.)	100	100	100	100	100
Evaporator Coil Face Area (ft²)	7.8	7.8	7.8	7.8	7.8
Rows Deep / Fins per Inch	4 / 16	4 / 16	4 / 16	4 / 16	4 / 16
<b>BELT DRIVE EVAP FAN DATA</b>					
# of Wheels (D x W)	----	----	1 (11" x 10")	1 (11" x 10")	1 (11" x 10")
Motor Sheave	----	----	VL40 x ¾"	VL40 x ¾"	VL40 x ¾"
Blower Sheave / Belt	----	----	AK61 X 1/ AX52	AK61 X 1/ AX52	AK61 X 1/ AX52
<b>CONDENSER FAN / COIL</b>					
Quantity of Condenser Fan Motors	1	1	1	1	1
Horsepower - RPM	¼ - 1,075	¼ - 1,075	¼ - 1,075	¼ - 1,075	¼ - 1,075
Fan Diameter / # Fan Blades	22 / 4	22 / 4	22 / 4	22 / 4	22 / 4
Outdoor Nominal CFM	3,800	3,800	3,800	3,800	3,800
Face Area (ft²)	13	13	13	13	13
Rows Deep/ Fins per Inch	2 / 27	2 / 27	2 / 27	2 / 27	2 / 27
<b>COMPRESSOR</b>					
Quantity / Type/ Stage	1 / Scroll / Single	1 / Scroll / Single	1 / Scroll / Single	1 / Scroll / Single	1 / Scroll / Single
Compressor RLA / LRA	26.4 / 134.0	16.0 / 110.0	16.0 / 110.0	7.8 / 52.0	5.7 / 38.9
<b>ELECTRICAL DATA</b>					
Voltage-Phase-Frequency	208/230-1-60	208/230-3-60	208/230-3-60	460-3-60	575-3-60
Indoor Blower HP / FLA	1.0 / 6.9	1.0 / 6.9	1.0 / 3.2 - 3.0	1.0 / 1.5	1.0 / 1.2
Max. External Static	0.9"	0.9"	1.0"	1.0"	1.0"
Outdoor Fan HP / FLA	¼ / 1.40	¼ / 1.40	¼ / 1.40	¼ / 0.7	¼ / 0.55
Min. Circuit Ampacity <sup>1</sup>	41.3 / 41.3	28.3 / 28.3	24.6 / 24.6	11.9	8.9
Max. Overcurrent Protection (amps) <sup>2</sup>	60 / 60	40 / 40	40 / 40	15	15
Power Supply Conduit Hole	1.125"	1.125"	1.125"	1.125"	1.125"
Low-Voltage Conduit Hole	½"	½"	½"	½"	½"
<b>OPERATING WEIGHT (LBS)</b>					
	620	620	620	620	620
<b>SHIP WEIGHT (LBS)</b>					
	645	645	645	645	645

<sup>1</sup> Wire size should be determined in accordance with National Electrical Codes. Extensive wire runs will require larger wire sizes.

<sup>2</sup> May use fuses or HACR-type circuit breakers of the same size as noted.

**NOTES**

- Always check the S&R plate for electrical data on the unit being installed.

IDB		OUTDOOR AMBIENT TEMPERATURE																																				
		65						75						85						95						105						115						
		AIRFLOW			59			63			67			71			59			63			67			71			59			63			67			71
		ENTERING INDOOR WET BULB TEMPERATURE																																				
<b>70</b>	MBh	36.7	38.1	41.7	-	35.9	37.2	40.8	-	35.0	36.3	39.8	-	34.2	35.4	38.8	-	32.5	33.7	36.9	-	30.1	31.2	34.2	-													
	S/T	0.75	0.63	0.44	-	0.78	0.65	0.45	-	0.80	0.67	0.46	-	0.83	0.69	0.48	-	0.86	0.72	0.50	-	0.86	0.72	0.50	-													
	Delta T	19	16	12	-	19	17	13	-	19	17	13	-	19	17	13	-	19	16	12	-	18	15	12	-													
	KW	2.46	2.51	2.58	-	2.63	2.69	2.77	-	2.79	2.85	2.93	-	2.93	2.99	3.08	-	3.04	3.10	3.20	-	3.14	3.21	3.31	-													
	AMPS	7.3	7.5	7.7	-	7.9	8.0	8.3	-	8.5	8.7	8.9	-	9.0	9.2	9.5	-	9.6	9.8	10.1	-	10.1	10.3	10.6	-													
<b>1350</b>	HI PR	237	255	270	-	266	287	303	-	303	326	341	-	345	371	392	-	388	418	441	-	429	461	487	-													
	LO PR	112	119	130	-	118	125	137	-	123	130	142	-	129	137	149	-	135	143	157	-	139	148	162	-													
	MBh	35.7	37.0	40.5	-	34.8	36.1	39.6	-	34.0	35.3	38.6	-	33.2	34.4	37.7	-	31.5	32.7	35.8	-	29.2	30.3	33.2	-													
	S/T	0.72	0.60	0.42	-	0.74	0.62	0.43	-	0.76	0.64	0.44	-	0.79	0.66	0.46	-	0.82	0.68	0.47	-	0.82	0.68	0.47	-													
	Delta T	20	17	13	-	20	17	13	-	20	17	13	-	20	17	13	-	20	17	13	-	18	16	12	-													
<b>1200</b>	KW	2.44	2.49	2.56	-	2.61	2.67	2.75	-	2.77	2.82	2.91	-	2.90	2.96	3.05	-	3.02	3.08	3.18	-	3.12	3.18	3.28	-													
	AMPS	7.3	7.4	7.7	-	7.8	8.0	8.2	-	8.4	8.6	8.9	-	9.0	9.2	9.4	-	9.5	9.7	10.0	-	10.0	10.2	10.6	-													
	HI PR	235	253	267	-	264	284	300	-	300	323	341	-	342	368	388	-	384	413	437	-	424	457	482	-													
	LO PR	110	118	128	-	117	124	136	-	121	129	141	-	127	136	148	-	134	142	155	-	138	147	160	-													
	MBh	32.9	34.1	37.4	-	32.2	33.3	36.5	-	31.4	32.5	35.7	-	30.6	31.7	34.8	-	29.1	30.2	33.0	-	27.0	27.9	30.6	-													
<b>1050</b>	S/T	0.69	0.58	0.40	-	0.72	0.60	0.42	-	0.74	0.61	0.43	-	0.76	0.63	0.44	-	0.79	0.66	0.46	-	0.80	0.66	0.46	-													
	Delta T	20	17	13	-	20	17	13	-	20	18	13	-	20	18	13	-	20	17	13	-	19	16	12	-													
	KW	2.39	2.43	2.50	-	2.56	2.61	2.68	-	2.70	2.76	2.84	-	2.84	2.89	2.98	-	2.95	3.01	3.10	-	3.04	3.11	3.20	-													
	AMPS	7.1	7.3	7.5	-	7.6	7.8	8.0	-	8.2	8.4	8.6	-	8.7	8.9	9.2	-	9.2	9.4	9.7	-	9.7	10.0	10.3	-													
	HI PR	228	245	259	-	256	275	291	-	291	313	331	-	331	356	376	-	373	401	423	-	412	443	468	-													
LO PR	107	114	124	-	113	120	131	-	118	125	137	-	124	131	144	-	130	138	150	-	134	143	156	-														
<b>75</b>	MBh	37.4	38.5	41.6	44.7	36.5	37.6	40.7	43.7	35.6	36.7	39.7	42.6	34.8	35.8	38.7	41.6	33.0	34.0	36.8	39.5	30.6	31.5	34.1	36.6													
	S/T	0.86	0.77	0.58	0.37	0.89	0.79	0.60	0.39	0.91	0.81	0.62	0.40	0.94	0.84	0.64	0.41	0.97	0.87	0.66	0.42	0.98	0.88	0.67	0.43													
	Delta T	22	21	16	11	22	20	17	11	22	21	17	12	22	20	17	12	22	21	17	12	21	20	15	11													
	KW	2.48	2.53	2.60	2.68	2.65	2.71	2.79	2.87	2.81	2.87	2.96	3.05	2.95	3.01	3.10	3.20	3.07	3.13	3.23	3.33	3.17	3.23	3.34	3.44													
	AMPS	7.4	7.6	7.8	8.0	7.9	8.1	8.4	8.6	8.6	8.8	9.0	9.3	9.1	9.3	9.6	9.9	9.6	9.9	10.2	10.5	10.2	10.4	10.7	11.1													
<b>1350</b>	HI PR	240	258	272	284	269	289	306	319	306	329	348	363	348	375	396	413	392	422	445	465	433	466	492	513													
	LO PR	113	120	131	139	119	127	138	147	124	132	144	153	130	138	151	161	136	145	158	169	141	150	164	174													
	MBh	36.3	37.4	40.4	43.4	35.4	36.5	39.5	42.4	34.6	35.6	38.5	41.4	33.7	34.7	37.6	40.4	32.1	33.0	35.7	38.3	29.7	30.6	33.1	35.5													
	S/T	0.82	0.73	0.55	0.36	0.85	0.76	0.57	0.37	0.87	0.78	0.59	0.38	0.90	0.80	0.61	0.39	0.93	0.83	0.63	0.40	0.94	0.84	0.63	0.41													
	Delta T	23	21	17	12	23	21	17	12	23	21	17	12	23	21	17	12	23	21	17	12	21	20	16	11													
<b>1200</b>	KW	2.46	2.51	2.58	2.66	2.63	2.69	2.77	2.85	2.79	2.85	2.93	3.02	2.93	3.01	3.10	3.18	3.04	3.11	3.20	3.30	3.14	3.21	3.31	3.42													
	AMPS	7.3	7.5	7.7	8.0	7.9	8.1	8.3	8.6	8.5	8.7	8.9	9.3	9.0	9.2	9.5	9.9	9.6	9.8	10.1	10.4	10.1	10.3	10.6	11.0													
	HI PR	237	255	270	281	266	287	303	316	303	326	344	359	345	371	392	409	388	418	441	460	429	461	487	508													
	LO PR	112	119	130	138	118	125	137	146	123	130	142	152	129	137	149	159	135	144	157	167	140	148	162	173													
	MBh	33.5	34.5	37.3	40.0	32.7	33.7	36.4	39.1	31.9	32.9	35.6	38.2	31.1	32.1	34.7	37.3	29.6	30.5	33.0	35.4	27.4	28.2	30.5	32.8													
<b>1050</b>	S/T	0.79	0.70	0.53	0.34	0.82	0.73	0.55	0.36	0.84	0.75	0.57	0.36	0.86	0.77	0.58	0.38	0.90	0.80	0.61	0.39	0.90	0.81	0.61	0.39													
	Delta T	23	21	17	12	23	22	18	12	23	22	18	12	24	22	18	12	23	21	18	12	22	20	16	11													
	KW	2.41	2.45	2.52	2.60	2.58	2.63	2.70	2.79	2.73	2.78	2.86	2.95	2.86	2.92	3.01	3.10	2.97	3.03	3.13	3.22	3.07	3.13	3.23	3.33													
	AMPS	7.2	7.3	7.5	7.8	7.7	7.9	8.1	8.4	8.3	8.5	8.7	9.0	8.8	9.0	9.3	9.6	9.3	9.5	9.8	10.2	9.8	10.1	10.4	10.7													
	HI PR	230	248	262	273	258	278	294	306	294	316	334	348	335	360	380	397	376	405	428	446	416	448	473	493													
LO PR	108	115	126	134	114	122	133	141	119	126	138	147	125	133	145	154	131	139	152	162	135	144	157	167														

Shaded area reflects ACCA (TVA) Rating conditions  
 kW = Total system power  
 Amps = outdoor unit amps (comp.+fan)

IDB = Entering Indoor Dry Bulb Temperature  
 High and low pressures are measured at the liquid and suction service valves.

Shaded area reflects ACCA (TVA) Rating conditions  
 kW = Total system power  
 Amps = outdoor unit amps (comp.+fan)

IDB		OUTDOOR AMBIENT TEMPERATURE												ENTERING INDOOR WET BULB TEMPERATURE											
		65				75				85				95				105				115			
		59	63	67	71	59	63	67	71	59	63	67	71	59	63	67	71	59	63	67	71	59	63	67	71
<b>1350</b>	MBh	38.0	38.9	41.5	44.4	37.1	38.0	40.6	43.3	36.3	37.1	39.6	42.3	35.4	36.1	38.6	41.3	33.6	34.3	36.7	39.2	33.6	34.3	36.7	39.2
	S/T	0.94	0.88	0.72	0.54	1.00	0.91	0.74	0.56	1.00	0.94	0.76	0.57	1.00	0.97	0.79	0.59	1.00	1.00	0.82	0.61	1.00	1.00	0.82	0.61
	Delta T	24	23	20	16	25	24	21	16	25	24	21	16	24	24	21	17	23	23	20	16	23	23	20	16
	KW	2.50	2.55	2.62	2.70	2.67	2.73	2.81	2.90	2.83	2.89	2.98	3.07	2.97	3.03	3.13	3.23	3.09	3.15	3.25	3.36	3.09	3.15	3.25	3.36
	AMPS	7.5	7.6	7.9	8.1	8.0	8.2	8.4	8.7	8.6	8.8	9.1	9.4	9.2	9.4	9.7	10.0	9.7	10.0	10.3	10.6	9.7	10.0	10.3	10.6
	HI PR	242	261	275	287	272	292	309	322	309	333	351	366	352	379	400	417	396	426	450	469	396	426	450	469
LO PR	114	121	132	141	120	128	140	149	125	133	145	155	131	140	153	162	138	146	160	170	138	146	160	170	
<b>1200</b>	MBh	36.9	37.7	40.3	43.1	36.1	36.9	39.4	42.1	35.2	36.0	38.4	41.1	34.3	35.1	37.5	40.1	32.6	33.3	35.6	38.1	32.6	33.3	35.6	38.1
	S/T	0.90	0.84	0.68	0.51	0.93	0.87	0.71	0.53	0.95	0.89	0.73	0.54	0.98	0.92	0.75	0.56	1.00	0.96	0.78	0.58	1.00	0.96	0.78	0.58
	Delta T	25	24	21	17	26	25	21	17	26	25	21	17	26	25	22	18	25	24	21	17	25	24	21	17
	KW	2.48	2.53	2.60	2.68	2.65	2.71	2.79	2.87	2.81	2.87	2.96	3.05	2.95	3.01	3.10	3.20	3.07	3.13	3.23	3.33	3.07	3.13	3.23	3.33
	AMPS	7.4	7.6	7.8	8.0	7.9	8.1	8.4	8.6	8.6	8.8	9.0	9.3	9.1	9.3	9.6	9.9	9.6	9.9	10.2	10.5	9.6	9.9	10.2	10.5
	HI PR	240	258	272	284	269	290	306	319	306	329	348	363	348	375	396	413	392	422	446	465	392	422	446	465
LO PR	113	120	131	139	119	127	138	147	124	132	144	153	130	138	151	161	136	145	158	169	136	145	158	169	
<b>1050</b>	MBh	34.1	34.8	37.2	39.8	33.3	34.0	36.3	38.8	32.5	33.2	35.5	37.9	31.7	32.4	34.6	37.0	30.1	30.8	32.9	35.1	30.1	30.8	32.9	35.1
	S/T	0.86	0.81	0.66	0.49	0.90	0.84	0.68	0.51	0.92	0.86	0.70	0.52	0.95	0.89	0.72	0.54	0.98	0.92	0.75	0.56	0.98	0.92	0.75	0.56
	Delta T	26	25	21	17	26	25	22	17	26	25	22	17	26	25	22	18	26	25	22	17	26	25	22	17
	KW	2.42	2.47	2.54	2.62	2.59	2.65	2.73	2.81	2.75	2.80	2.89	2.98	2.88	2.94	3.03	3.12	2.99	3.06	3.15	3.25	2.99	3.06	3.15	3.25
	AMPS	7.2	7.4	7.6	7.9	7.7	7.9	8.2	8.4	8.4	8.5	8.8	9.1	8.9	9.1	9.4	9.7	9.4	9.6	9.9	10.3	9.4	9.6	9.9	10.3
	HI PR	233	250	264	276	261	281	297	309	297	319	337	352	338	364	384	401	380	409	432	451	380	409	432	451
LO PR	109	116	127	135	116	123	134	143	120	128	139	149	126	134	146	156	132	141	154	163	132	141	154	163	

<b>1350</b>	MBh	38.7	39.4	41.3	44.1	37.8	38.5	40.3	43.0	36.9	37.6	39.4	42.0	36.0	36.7	38.4	41.0	34.2	34.9	36.5	38.9	34.2	34.9	36.5	38.9
	S/T	0.98	0.95	0.86	0.70	1.00	0.98	0.89	0.72	1.00	1.00	0.91	0.74	1.00	1.00	0.94	0.76	1.00	1.00	0.98	0.79	1.00	1.00	0.98	0.79
	Delta T	26	26	24	21	26	26	24	21	25	26	24	21	25	25	25	21	23	24	24	21	23	24	24	21
	KW	2.51	2.56	2.64	2.72	2.69	2.75	2.83	2.92	2.85	2.91	3.00	3.10	2.99	3.06	3.15	3.25	3.11	3.18	3.28	3.38	3.11	3.18	3.28	3.38
	AMPS	7.5	7.7	7.9	8.2	8.1	8.3	8.5	8.8	8.7	8.9	9.2	9.5	9.3	9.5	9.8	10.1	9.8	10.0	10.4	10.7	9.8	10.0	10.4	10.7
	HI PR	245	263	278	290	274	295	312	325	312	336	355	370	355	383	404	421	400	430	454	474	400	430	454	474
LO PR	115	122	134	142	121	129	141	150	126	134	147	156	133	141	154	164	139	148	161	172	139	148	161	172	
<b>1200</b>	MBh	37.6	38.3	40.1	42.8	36.7	37.4	39.2	41.8	35.8	36.5	38.2	40.8	34.9	35.6	37.3	39.8	33.2	33.8	35.4	37.8	33.2	33.8	35.4	37.8
	S/T	0.94	0.91	0.82	0.66	0.97	0.94	0.85	0.69	1.00	0.96	0.87	0.71	1.00	0.99	0.90	0.73	1.00	1.00	0.93	0.76	1.00	1.00	0.93	0.76
	Delta T	27	27	25	22	27	27	25	22	27	27	25	22	27	27	26	22	25	26	25	22	25	26	25	22
	KW	2.50	2.55	2.62	2.70	2.67	2.73	2.81	2.90	2.83	2.89	2.98	3.07	2.97	3.03	3.13	3.23	3.09	3.15	3.25	3.36	3.09	3.15	3.25	3.36
	AMPS	7.5	7.6	7.9	8.1	8.0	8.2	8.4	8.7	8.6	8.8	9.1	9.4	9.2	9.4	9.7	10.0	9.7	10.0	10.3	10.6	9.7	10.0	10.3	10.6
	HI PR	242	261	275	287	272	292	309	322	309	333	351	366	352	379	400	417	396	426	450	469	396	426	450	469
LO PR	114	121	132	141	120	128	140	149	125	133	145	155	131	140	153	162	138	146	160	170	138	146	160	170	
<b>1050</b>	MBh	34.7	35.3	37.0	39.5	33.9	34.5	36.2	38.6	33.1	33.7	35.3	37.7	32.3	32.9	34.4	36.7	30.6	31.2	32.7	34.9	30.6	31.2	32.7	34.9
	S/T	0.91	0.87	0.79	0.64	0.94	0.91	0.82	0.66	0.96	0.93	0.84	0.68	0.99	0.96	0.86	0.70	1.00	0.99	0.90	0.73	1.00	0.99	0.90	0.73
	Delta T	27	27	26	22	28	27	26	22	28	27	26	22	28	28	26	23	27	27	26	22	27	27	26	22
	KW	2.44	2.49	2.56	2.64	2.61	2.67	2.75	2.83	2.77	2.82	2.91	3.00	2.90	2.96	3.05	3.15	3.02	3.08	3.18	3.28	3.02	3.08	3.18	3.28
	AMPS	7.3	7.4	7.7	7.9	7.8	8.0	8.2	8.5	8.4	8.6	8.9	9.2	9.0	9.2	9.4	9.8	9.5	9.7	10.0	10.3	9.5	9.7	10.0	10.3
	HI PR	235	253	267	278	264	284	300	312	300	323	341	355	341	367	388	405	384	413	436	455	384	413	436	455
LO PR	110	117	128	137	117	124	136	144	121	129	141	150	127	136	148	158	133	142	155	165	133	142	155	165	

IDB = Entering Indoor Dry Bulb Temperature  
 High and low pressures are measured at the liquid and suction service valves.  
 Shaded area reflects AHRI Rating conditions  
 kW = Total system power  
 Amps = outdoor unit amps (comp.+fan)

IDB		OUTDOOR AMBIENT TEMPERATURE												ENTERING INDOOR WET BULB TEMPERATURE											
		65				75				85				95				105				115			
		59	63	67	71	59	63	67	71	59	63	67	71	59	63	67	71	59	63	67	71	59	63	67	71
<b>70</b>	MBh	46.0	47.7	52.3	-	45.0	46.6	51.1	-	43.9	45.5	49.9	-	42.8	44.4	48.6	-	40.7	42.2	46.2	-	37.7	39.1	42.8	-
	S/T	0.77	0.64	0.45	-	0.80	0.67	0.46	-	0.82	0.68	0.47	-	0.84	0.70	0.49	-	0.88	0.73	0.51	-	0.88	0.74	0.51	-
	Delta T	18	16	12	-	18	16	12	-	18	16	12	-	18	16	12	-	18	16	12	-	17	15	11	-
	KW	3.10	3.17	3.26	-	3.33	3.40	3.50	-	3.53	3.60	3.72	-	3.71	3.78	3.90	-	3.86	3.94	4.06	-	3.99	4.07	4.20	-
	AMPS	8.1	8.3	8.6	-	8.7	8.9	9.2	-	9.4	9.7	10.0	-	10.1	10.3	10.6	-	10.7	10.9	11.2	-	11.3	11.5	11.9	-
	HI PR	240	259	273	-	270	290	306	-	307	330	348	-	349	376	397	-	393	423	447	-	434	467	493	-
	LO PR	112	119	130	-	118	126	138	-	123	131	143	-	129	138	150	-	135	144	157	-	140	149	163	-
	MBh	44.7	46.3	50.8	-	43.7	45.3	49.6	-	42.6	44.2	48.4	-	41.6	43.1	47.2	-	39.5	40.9	44.9	-	36.6	37.9	41.6	-
	S/T	0.73	0.61	0.42	-	0.76	0.64	0.44	-	0.78	0.65	0.45	-	0.80	0.67	0.47	-	0.84	0.70	0.48	-	0.84	0.70	0.49	-
	Delta T	19	16	12	-	19	17	13	-	19	17	13	-	19	17	13	-	19	16	12	-	18	15	12	-
KW	3.08	3.14	3.24	-	3.31	3.37	3.48	-	3.50	3.58	3.69	-	3.68	3.75	3.87	-	3.83	3.91	4.03	-	3.95	4.04	4.17	-	
AMPS	8.1	8.3	8.5	-	8.7	8.9	9.1	-	9.4	9.6	9.9	-	10.0	10.2	10.5	-	10.6	10.8	11.2	-	11.2	11.4	11.8	-	
HI PR	238	256	270	-	267	287	303	-	304	327	345	-	346	372	393	-	389	419	442	-	430	463	488	-	
LO PR	111	118	129	-	117	125	136	-	122	130	142	-	128	136	149	-	134	143	156	-	139	148	161	-	
MBh	41.3	42.8	46.9	-	40.3	41.8	45.8	-	39.3	40.8	44.7	-	38.4	39.8	43.6	-	36.5	37.8	41.4	-	33.8	35.0	38.4	-	
S/T	0.71	0.59	0.41	-	0.73	0.61	0.42	-	0.75	0.63	0.44	-	0.78	0.65	0.45	-	0.81	0.67	0.47	-	0.81	0.68	0.47	-	
Delta T	19	17	13	-	19	17	13	-	19	17	13	-	20	17	13	-	19	17	13	-	18	16	12	-	
KW	3.01	3.07	3.16	-	3.23	3.30	3.39	-	3.42	3.49	3.60	-	3.59	3.67	3.78	-	3.73	3.81	3.93	-	3.86	3.94	4.07	-	
AMPS	7.9	8.0	8.3	-	8.5	8.6	8.9	-	9.1	9.3	9.6	-	9.7	9.9	10.2	-	10.3	10.5	10.9	-	10.9	11.1	11.5	-	
HI PR	231	248	262	-	259	279	294	-	295	317	335	-	335	361	381	-	377	406	429	-	417	449	474	-	
LO PR	108	115	125	-	114	121	132	-	118	126	137	-	124	132	144	-	130	138	151	-	135	143	156	-	
<b>75</b>	MBh	46.8	48.2	52.2	56.0	45.7	47.1	51.0	54.7	44.6	46.0	49.8	53.4	43.6	44.8	48.5	52.1	41.4	42.6	46.1	49.5	38.3	39.5	42.7	45.8
	S/T	0.87	0.78	0.59	0.38	0.91	0.81	0.61	0.39	0.93	0.83	0.63	0.40	0.96	0.86	0.65	0.42	1.00	0.89	0.67	0.43	1.00	0.90	0.68	0.44
	Delta T	21	19	16	11	21	19	16	11	21	20	16	11	21	20	16	11	21	20	16	11	20	18	15	10
	KW	3.13	3.19	3.29	3.39	3.36	3.43	3.53	3.64	3.56	3.63	3.75	3.86	3.74	3.82	3.94	4.06	3.89	3.97	4.10	4.23	4.02	4.10	4.24	4.37
	AMPS	8.2	8.4	8.6	8.9	8.8	9.0	9.3	9.6	9.5	9.7	10.0	10.4	10.1	10.4	10.7	11.1	10.8	11.0	11.4	11.8	11.4	11.6	12.0	12.4
	HI PR	243	261	276	288	272	293	310	323	310	333	352	367	353	380	401	418	397	427	451	470	439	472	498	520
	LO PR	113	120	132	140	120	127	139	148	124	132	144	154	131	139	152	162	137	146	159	169	142	151	164	175
	MBh	45.5	46.8	50.7	54.4	44.4	45.7	49.5	53.1	43.3	44.6	48.3	51.8	42.3	43.5	47.1	50.6	40.2	41.4	44.8	48.1	37.2	38.3	41.5	44.5
	S/T	0.83	0.75	0.56	0.36	0.86	0.77	0.59	0.38	0.89	0.79	0.60	0.39	0.91	0.82	0.62	0.40	0.95	0.85	0.64	0.41	0.96	0.86	0.65	0.42
	Delta T	22	20	16	11	22	20	17	11	22	20	17	12	22	20	17	12	22	20	17	11	20	19	15	11
KW	3.11	3.17	3.26	3.36	3.33	3.40	3.50	3.61	3.53	3.60	3.72	3.83	3.71	3.79	3.90	4.03	3.86	3.94	4.06	4.20	3.99	4.07	4.20	4.34	
AMPS	8.1	8.3	8.6	8.9	8.7	8.9	9.2	9.5	9.4	9.7	10.0	10.3	10.1	10.3	10.6	11.0	10.7	10.9	11.3	11.7	11.3	11.5	11.9	12.3	
HI PR	240	259	273	285	270	290	306	320	307	330	349	364	349	376	397	414	393	423	447	466	434	467	493	515	
LO PR	112	119	130	139	118	126	138	147	123	131	143	152	129	138	150	160	136	144	157	168	140	149	163	173	
MBh	42.0	43.2	46.8	50.2	41.0	42.2	45.7	49.0	40.0	41.2	44.6	47.9	39.0	40.2	43.5	46.7	37.1	38.2	41.3	44.4	34.3	35.4	38.3	41.1	
S/T	0.80	0.72	0.54	0.35	0.83	0.75	0.56	0.36	0.85	0.76	0.58	0.37	0.88	0.79	0.60	0.38	0.92	0.82	0.62	0.40	0.92	0.83	0.63	0.40	
Delta T	22	20	17	12	22	21	17	12	22	21	17	12	23	21	17	12	23	21	17	12	21	19	16	11	
KW	3.04	3.10	3.19	3.28	3.25	3.32	3.42	3.53	3.45	3.52	3.63	3.74	3.62	3.69	3.81	3.93	3.76	3.84	3.97	4.09	3.89	3.97	4.10	4.23	
AMPS	7.9	8.1	8.4	8.6	8.5	8.7	9.0	9.3	9.2	9.4	9.7	10.0	9.8	10.0	10.3	10.7	10.4	10.6	11.0	11.3	11.0	11.2	11.6	12.0	
HI PR	233	251	265	276	262	282	297	310	298	320	338	353	339	365	385	402	381	410	433	452	421	453	479	499	
LO PR	109	116	126	135	115	122	133	142	119	127	139	148	125	133	146	155	131	140	153	163	136	145	158	168	

IDB = Entering Indoor Dry Bulb Temperature  
 High and low pressures are measured at the liquid and suction service valves.  
 Shaded area reflects ACCA (TVA) Rating conditions  
 kW = Total system power  
 Amps = outdoor unit amps (comp.+fan)

EXPANDED COOLING DATA — 4 TONS (CONT.)

IDB		OUTDOOR AMBIENT TEMPERATURE												ENTERING INDOOR WET BULB TEMPERATURE											
		65				75				85				95				105				115			
		59	63	67	71	59	63	67	71	59	63	67	71	59	63	67	71	59	63	67	71	59	63	67	71
<b>1800</b>	MBh	47.7	48.7	52.0	55.6	46.5	47.6	50.8	54.3	45.4	46.4	49.6	53.0	44.3	45.3	48.4	51.7	42.1	43.0	46.0	49.1	39.0	39.9	42.6	45.5
	S/T	0.96	0.90	0.73	0.55	1.00	0.93	0.76	0.57	1.00	0.96	0.78	0.58	1.00	1.00	0.80	0.60	1.00	1.00	0.83	0.62	1.00	1.00	0.84	0.63
	Delta T	23	22	19	16	24	23	20	16	23	23	20	16	23	23	20	16	22	22	20	16	20	20	18	15
	KW	3.15	3.22	3.31	3.41	3.38	3.45	3.56	3.67	3.59	3.66	3.78	3.90	3.77	3.85	3.97	4.10	3.92	4.00	4.13	4.26	4.05	4.14	4.27	4.41
	AMPS	8.3	8.5	8.7	9.0	8.9	9.1	9.4	9.7	9.6	9.8	10.1	10.5	10.2	10.5	10.8	11.2	10.8	11.1	11.5	11.9	11.5	11.7	12.1	12.5
	HI PR	245	264	279	291	275	296	313	326	313	337	356	371	356	384	405	422	401	431	456	475	443	477	503	525
LO PR	114	122	133	141	121	129	140	149	126	134	146	155	132	140	153	163	138	147	161	171	143	152	166	177	
<b>1600</b>	MBh	46.3	47.3	50.5	54.0	45.2	46.2	49.3	52.7	44.1	45.1	48.2	51.5	43.0	44.0	47.0	50.2	40.9	41.8	44.6	47.7	37.9	38.7	41.3	44.2
	S/T	0.91	0.86	0.70	0.52	0.95	0.89	0.72	0.54	0.97	0.91	0.74	0.55	1.00	0.94	0.77	0.57	1.00	0.98	0.80	0.59	1.00	0.98	0.80	0.60
	Delta T	24	23	20	16	25	24	21	16	25	24	21	16	25	24	21	17	23	23	20	16	22	22	19	15
	KW	3.13	3.19	3.29	3.39	3.36	3.43	3.53	3.64	3.56	3.63	3.75	3.87	3.74	3.82	3.94	4.06	3.89	3.97	4.10	4.23	4.02	4.10	4.24	4.38
	AMPS	8.2	8.4	8.6	8.9	8.8	9.0	9.3	9.6	9.5	9.7	10.0	10.4	10.1	10.4	10.7	11.1	10.8	11.0	11.4	11.8	11.4	11.6	12.0	12.4
	HI PR	243	261	276	288	272	293	310	323	310	333	352	367	353	380	401	418	397	427	451	471	439	472	498	520
LO PR	113	120	132	140	120	127	139	148	124	132	144	154	131	139	152	162	137	146	159	169	142	151	164	175	
<b>1400</b>	MBh	42.7	43.6	46.6	49.8	41.7	42.6	45.5	48.7	40.7	41.6	44.5	47.5	39.7	40.6	43.4	46.4	37.7	38.6	41.2	44.0	35.0	35.7	38.2	40.8
	S/T	0.88	0.83	0.67	0.50	0.91	0.86	0.70	0.52	0.94	0.88	0.72	0.53	0.97	0.91	0.74	0.55	1.00	0.94	0.77	0.57	1.01	0.95	0.77	0.58
	Delta T	25	24	21	16	25	24	21	17	25	24	21	17	25	24	21	17	25	24	21	17	23	22	19	15
	KW	3.06	3.12	3.21	3.31	3.28	3.35	3.45	3.56	3.48	3.55	3.66	3.77	3.65	3.72	3.84	3.96	3.79	3.88	4.00	4.13	3.92	4.00	4.13	4.27
	AMPS	8.0	8.2	8.4	8.7	8.6	8.8	9.1	9.4	9.3	9.5	9.8	10.1	9.9	10.1	10.4	10.8	10.5	10.7	11.1	11.4	11.1	11.3	11.7	12.1
	HI PR	235	253	268	279	264	284	300	313	301	323	342	356	342	368	389	406	385	414	438	456	425	458	483	504
LO PR	110	117	128	136	116	123	135	144	121	128	140	149	127	135	147	157	133	141	154	164	137	146	160	170	
<b>1800</b>	MBh	48.5	49.4	51.8	55.2	47.4	48.3	50.6	53.9	46.2	47.1	49.4	52.7	45.1	46.0	48.2	51.4	42.8	43.7	45.7	48.8	39.7	40.5	42.4	45.2
	S/T	1.00	0.97	0.88	0.71	1.00	1.00	0.91	0.74	1.00	1.00	0.93	0.76	1.00	1.00	0.96	0.78	1.00	1.00	1.00	0.81	1.00	1.00	1.00	0.82
	Delta T	25	24	23	20	24	25	23	20	24	24	23	20	23	23	24	20	22	22	23	20	20	21	22	19
	KW	3.18	3.24	3.34	3.44	3.41	3.48	3.59	3.70	3.61	3.69	3.81	3.93	3.80	3.88	4.00	4.13	3.95	4.04	4.16	4.30	4.08	4.17	4.31	4.45
	AMPS	8.3	8.5	8.8	9.1	9.0	9.2	9.5	9.8	9.7	9.9	10.2	10.6	10.3	10.6	10.9	11.3	10.9	11.2	11.6	12.0	11.6	11.8	12.2	12.6
	HI PR	248	267	281	294	278	299	316	329	316	340	359	375	360	387	409	427	405	436	460	480	447	482	508	530
LO PR	116	123	134	143	122	130	142	151	127	135	147	157	133	142	155	165	140	149	162	173	144	154	168	179	
<b>1600</b>	MBh	47.1	48.0	50.3	53.6	46.0	46.9	49.1	52.4	44.9	45.8	47.9	51.1	43.8	44.6	46.8	49.9	41.6	42.4	44.4	47.4	38.5	39.3	41.1	43.9
	S/T	0.96	0.93	0.84	0.68	0.99	0.96	0.87	0.70	1.00	0.98	0.89	0.72	1.00	1.00	0.92	0.74	1.00	1.00	0.95	0.77	1.00	1.00	0.96	0.78
	Delta T	26	26	24	21	26	26	24	21	26	26	24	21	25	26	25	21	24	24	24	21	22	23	23	20
	KW	3.15	3.22	3.31	3.41	3.38	3.45	3.56	3.67	3.59	3.66	3.78	3.90	3.77	3.85	3.97	4.10	3.92	4.00	4.13	4.26	4.05	4.14	4.27	4.41
	AMPS	8.3	8.5	8.7	9.0	8.9	9.1	9.4	9.7	9.6	9.8	10.1	10.5	10.2	10.5	10.8	11.2	10.8	11.1	11.5	11.9	11.5	11.7	12.1	12.5
	HI PR	245	264	279	291	275	296	313	326	313	337	356	371	356	384	405	422	401	431	456	475	443	477	503	525
LO PR	114	122	133	141	121	129	140	149	126	134	146	155	132	140	153	163	138	147	161	171	143	152	166	177	
<b>1400</b>	MBh	43.5	44.3	46.4	49.5	42.4	43.3	45.3	48.3	41.4	42.2	44.2	47.2	40.4	41.2	43.2	46.0	38.4	39.1	41.0	43.7	35.6	36.3	38.0	40.5
	S/T	0.92	0.89	0.81	0.65	0.96	0.92	0.83	0.68	0.98	0.95	0.86	0.69	1.00	0.98	0.88	0.72	1.00	1.00	0.92	0.74	1.00	1.00	0.92	0.75
	Delta T	26	26	25	21	27	26	25	21	27	26	25	22	27	26	25	22	25	26	25	21	23	24	23	20
	KW	3.08	3.14	3.24	3.33	3.30	3.37	3.48	3.58	3.50	3.58	3.69	3.80	3.68	3.75	3.87	4.00	3.82	3.91	4.03	4.16	3.95	4.04	4.17	4.30
	AMPS	8.1	8.2	8.5	8.8	8.7	8.9	9.1	9.5	9.4	9.6	9.9	10.2	10.0	10.2	10.5	10.9	10.6	10.8	11.1	11.5	11.2	11.4	11.8	12.2
	HI PR	238	256	270	282	267	287	303	316	304	327	345	360	346	372	393	410	389	419	442	461	430	462	488	509
LO PR	111	118	129	137	117	125	136	145	122	130	141	151	128	136	149	158	134	143	156	166	139	148	161	172	

Shaded area reflects AHRI Rating conditions  
 KW = Total system power  
 Amps = outdoor unit amps (comp.+fan)



IDB	AIRFLOW	OUTDOOR AMBIENT TEMPERATURE															59	63	67	71	75	79	83	87	91	95	105					115				
		ENTERING INDOOR WET BULB TEMPERATURE																																		
		59	63	67	71	75	79	83	87	91	95	99	103	107	111	115																				
70	MBh	57.6	59.7	65.4	-	54.9	56.9	62.4	-	53.6	55.6	60.9	-	50.9	52.8	57.8	-	47.2	48.9	53.6	-	50.9	52.8	57.8	-	47.2	48.9	53.6	-							
	S/T	0.74	0.62	0.43	-	0.78	0.66	0.45	-	0.81	0.68	0.47	-	0.84	0.70	0.49	-	0.85	0.71	0.49	-	0.84	0.70	0.49	-	0.85	0.71	0.49	-							
	Delta T	19	17	13	-	19	17	13	-	19	17	13	-	19	17	13	-	18	16	12	-	19	17	13	-	18	16	12	-							
	KW	3.95	4.04	4.17	-	4.26	4.35	4.49	-	4.77	4.87	5.04	-	4.97	5.08	5.25	-	5.15	5.26	5.44	-	4.97	5.08	5.25	-	5.15	5.26	5.44	-							
	AMPS	10.2	10.4	10.7	-	11.0	11.2	11.6	-	11.9	12.2	12.6	-	13.5	13.9	14.3	-	14.3	14.7	15.2	-	13.5	13.9	14.3	-	14.3	14.7	15.2	-							
	HI PR	257	277	292	-	289	311	328	-	328	353	373	-	421	453	478	-	465	500	528	-	421	453	478	-	465	500	528	-							
	LO PR	107	114	124	-	113	120	131	-	117	125	136	-	123	131	143	-	134	142	155	-	123	131	143	-	134	142	155	-							
	MBh	55.9	58.0	63.5	-	54.6	56.6	62.0	-	53.3	55.3	60.6	-	49.4	51.2	56.1	-	45.8	47.5	52.0	-	49.4	51.2	56.1	-	45.8	47.5	52.0	-							
	S/T	0.70	0.59	0.41	-	0.73	0.61	0.42	-	0.75	0.62	0.43	-	0.80	0.67	0.46	-	0.81	0.68	0.47	-	0.80	0.67	0.46	-	0.81	0.68	0.47	-							
	Delta T	20	17	13	-	20	18	13	-	20	18	13	-	21	18	13	-	19	16	12	-	20	18	13	-	19	16	12	-							
KW	3.92	4.00	4.13	-	4.22	4.32	4.46	-	4.49	4.59	4.74	-	4.73	4.83	4.99	-	5.10	5.22	5.39	-	4.73	4.83	4.99	-	5.10	5.22	5.39	-								
AMPS	10.1	10.3	10.6	-	10.9	11.1	11.5	-	11.8	12.1	12.5	-	12.6	12.9	13.4	-	14.2	14.6	15.1	-	12.6	12.9	13.4	-	14.2	14.6	15.1	-								
HI PR	255	274	290	-	286	308	325	-	325	350	370	-	417	448	474	-	460	495	523	-	417	448	474	-	460	495	523	-								
LO PR	106	113	123	-	112	119	130	-	116	124	135	-	122	130	142	-	132	141	154	-	122	130	142	-	132	141	154	-								
MBh	51.6	53.5	58.6	-	50.4	52.3	57.3	-	49.2	51.0	55.9	-	45.6	47.3	51.8	-	42.3	43.8	48.0	-	45.6	47.3	51.8	-	42.3	43.8	48.0	-								
S/T	0.68	0.57	0.39	-	0.70	0.59	0.41	-	0.72	0.60	0.42	-	0.77	0.65	0.45	-	0.78	0.65	0.45	-	0.77	0.65	0.45	-	0.78	0.65	0.45	-								
Delta T	21	18	14	-	21	18	14	-	21	18	14	-	21	18	14	-	20	17	13	-	21	18	14	-	20	17	13	-								
KW	3.83	3.91	4.03	-	4.12	4.21	4.35	-	4.38	4.48	4.62	-	4.61	4.71	4.87	-	4.97	5.09	5.26	-	4.61	4.71	4.87	-	4.97	5.09	5.26	-								
AMPS	9.8	10.0	10.4	-	10.6	10.8	11.2	-	11.5	11.8	12.2	-	12.3	12.6	13.0	-	13.8	14.2	14.6	-	12.3	12.6	13.0	-	13.8	14.2	14.6	-								
HI PR	247	266	281	-	277	298	315	-	315	339	358	-	359	387	408	-	447	481	507	-	359	387	408	-	447	481	507	-								
LO PR	103	109	119	-	108	115	126	-	113	120	131	-	118	126	137	-	124	136	149	-	118	126	137	-	124	136	149	-								
75	MBh	58.6	60.3	65.3	70.1	57.2	58.9	63.8	68.5	55.9	57.5	62.3	66.8	54.5	56.1	60.7	65.2	51.8	53.3	57.7	61.9	51.8	53.3	57.7	61.9	48.0	49.4	53.5	57.4							
	S/T	0.84	0.75	0.57	0.37	0.87	0.78	0.59	0.38	0.89	0.80	0.60	0.39	0.92	0.82	0.62	0.40	0.96	0.85	0.65	0.42	0.96	0.85	0.65	0.42	0.96	0.86	0.65	0.42							
	Delta T	22	20	17	11	22	21	17	12	22	21	17	12	23	21	17	12	22	20	17	12	21	22	20	17	12	21	19	16	11						
	KW	3.98	4.07	4.20	4.34	4.29	4.39	4.53	4.68	4.57	4.67	4.82	4.98	4.81	4.92	5.08	5.25	5.01	5.13	5.30	5.48	5.19	5.01	5.13	5.30	5.48	5.19	5.31	5.49	5.68						
	AMPS	10.3	10.5	10.8	11.2	11.1	11.3	11.7	12.1	12.0	12.3	12.7	13.2	12.8	13.2	13.6	14.1	13.7	14.0	14.5	15.0	14.5	13.7	14.0	14.5	15.0	14.5	14.8	15.3	15.9						
	HI PR	260	280	295	308	292	314	332	346	332	357	377	393	378	407	429	448	425	458	483	504	470	425	458	483	504	470	506	534	557						
	LO PR	108	115	125	134	114	121	132	141	119	126	138	147	124	132	145	154	130	139	152	161	135	139	139	152	161	135	144	157	167						
	MBh	56.9	58.6	63.4	68.0	55.6	57.2	61.9	66.5	54.2	55.8	60.5	64.9	52.9	54.5	59.0	63.3	50.3	51.8	56.0	60.1	46.6	50.3	51.8	56.0	60.1	46.6	47.9	51.9	55.7						
	S/T	0.80	0.72	0.54	0.35	0.83	0.74	0.56	0.36	0.85	0.76	0.58	0.37	0.88	0.79	0.59	0.38	0.91	0.82	0.62	0.40	0.92	0.82	0.62	0.40	0.92	0.82	0.62	0.40							
	Delta T	23	21	18	12	24	22	18	12	24	22	18	12	24	22	18	12	23	22	18	12	22	22	22	18	12	22	20	16	11						
KW	3.95	4.04	4.17	4.30	4.26	4.35	4.49	4.64	4.53	4.63	4.78	4.94	4.77	4.88	5.04	5.21	4.97	5.08	5.25	5.43	5.15	4.97	5.08	5.25	5.43	5.15	5.26	5.44	5.63							
AMPS	10.2	10.4	10.7	11.1	11.0	11.2	11.6	12.0	11.9	12.2	12.6	13.1	12.7	13.0	13.5	14.0	13.5	13.9	14.3	14.9	14.3	13.5	13.9	14.3	14.9	14.3	14.7	15.2	15.8							
HI PR	257	277	293	305	289	311	328	342	329	354	373	389	374	403	425	443	421	453	478	499	465	421	453	478	499	465	501	529	551							
LO PR	107	114	124	132	113	120	131	140	117	125	136	145	123	131	143	152	129	137	150	160	134	129	137	150	160	134	142	155	165							
MBh	52.5	54.1	58.5	62.8	51.3	52.8	57.2	61.3	65.5	50.1	51.5	55.8	59.9	48.8	50.3	54.4	46.4	47.8	51.7	55.5	43.0	46.4	47.8	51.7	55.5	43.0	44.3	47.9	51.4							
S/T	0.77	0.69	0.52	0.34	0.80	0.72	0.54	0.35	0.82	0.73	0.56	0.36	0.85	0.76	0.57	0.37	0.88	0.79	0.59	0.38	0.89	0.79	0.59	0.38	0.89	0.79	0.60	0.39								
Delta T	24	22	18	13	24	22	18	13	24	22	18	13	25	23	19	13	24	22	18	13	23	22	22	18	13	23	21	17	12							
KW	3.86	3.94	4.06	4.20	4.16	4.25	4.38	4.53	4.42	4.51	4.66	4.82	4.65	4.75	4.91	5.07	4.85	4.96	5.12	5.29	5.02	4.85	4.96	5.12	5.29	5.02	5.13	5.30	5.48							
AMPS	9.9	10.1	10.5	10.8	10.7	10.9	11.3	11.7	11.6	11.9	12.3	12.7	12.4	12.7	13.1	13.6	13.2	13.5	13.9	14.5	14.0	13.2	13.5	13.9	14.5	14.0	14.3	14.8	15.3							
HI PR	250	269	284	296	280	302	318	332	319	343	362	378	363	391	412	430	408	439	464	484	451	408	439	464	484	451	486	513	535							
LO PR	104	110	120	128	110	117	127	135	114	121	132	141	120	127	139	148	125	133	146	155	130	125	133	146	155	130	138	151	160							

IDB = Entering Indoor Dry Bulb Temperature  
 High and low pressures are measured at the liquid and suction service valves.  
 Shaded area reflects ACCA (TVA) Rating conditions  
 kW = Total system power  
 Amps = outdoor unit amps (comp.+fan)



**STANDARD BELT DRIVE — DOWN SHOT**

ESP (" H <sub>2</sub> O)	TURNS OPEN											
	0		1		2		3		4		5	
	CFM	BHP	CFM	BHP	CFM	BHP	CFM	BHP	CFM	BHP	CFM	BHP
0.1	---	---	---	---	---	---	---	---	1279	0.31	1071	0.26
0.2	---	---	---	---	---	---	1291	0.32	1124	0.28	916	0.23
0.3	---	---	---	---	---	---	1134	0.30	969	0.25	717	0.21
0.4	---	---	---	---	1213	0.32	977	0.29	770	0.23	---	---
0.5	---	---	1227	0.38	1029	0.30	773	0.26	---	---	---	---
0.6	1283	0.43	1076	0.35	867	0.29	---	---	---	---	---	---
0.7	1125	0.40	891	0.31	699	0.27	---	---	---	---	---	---
0.8	949	0.37	696	0.29	---	---	---	---	---	---	---	---
0.9	687	0.33	---	---	---	---	---	---	---	---	---	---
1.0	634	0.30	---	---	---	---	---	---	---	---	---	---

**HIGH-STATIC BELT DRIVE — DOWN SHOT**

ESP (" H <sub>2</sub> O)	TURNS OPEN											
	0		1		2		3		4		5	
	CFM	BHP	CFM	BHP	CFM	BHP	CFM	BHP	CFM	BHP	CFM	BHP
0.6	---	---	---	---	---	---	---	---	---	---	---	---
0.7	---	---	---	---	---	---	---	---	---	---	1222	0.40
0.8	---	---	---	---	---	---	---	---	---	---	1117	0.39
0.9	---	---	---	---	---	---	---	---	1221	0.46	1012	0.38
1.0	---	---	---	---	---	---	1246	0.52	1078	0.42	869	0.35
1.1	---	---	---	---	---	---	1126	0.49	935	0.39	725	0.33
1.2	---	---	---	---	1268	0.56	1006	0.46	763	0.36	---	---
1.3	---	---	1335	0.65	1141	0.53	847	0.42	---	---	---	---
1.4	---	---	1212	0.62	1014	0.50	690	0.38	---	---	---	---
1.5	1314	0.72	1090	0.58	887	0.47	---	---	---	---	---	---
1.6	1187	0.67	922	0.53	750	0.43	---	---	---	---	---	---
1.7	1060	0.63	753	0.49	---	---	---	---	---	---	---	---
1.8	978	0.61	---	---	---	---	---	---	---	---	---	---

Note: Tables represent dry coil without filter; to compensate for filter, add 0.08" to measured E.S.P. SCFM correction for wet coil = 4%.

**STANDARD BELT DRIVE — HORIZONTAL**

ESP (" H2O)	TURNS OPEN											
	0		1		2		3		4		5	
	CFM	BHP	CFM	BHP	CFM	BHP	CFM	BHP	CFM	BHP	CFM	BHP
0.1	---	---	---	---	---	---	---	---	---	---	1190	0.29
0.2	---	---	---	---	---	---	---	---	1249	0.31	1018	0.26
0.3	---	---	---	---	---	---	1260	0.34	1077	0.28	797	0.24
0.4	---	---	---	---	1318	0.35	1085	0.33	856	0.26	---	---
0.5	---	---	1334	0.41	1119	0.33	859	0.30	---	---	---	---
0.6	1395	0.46	1170	0.38	942	0.31	---	---	---	---	---	---
0.7	1223	0.43	968	0.34	760	0.30	---	---	---	---	---	---
0.8	1032	0.40	756	0.31	---	---	---	---	---	---	---	---
0.9	747	0.36	---	---	---	---	---	---	---	---	---	---
1.0	688	0.33	---	---	---	---	---	---	---	---	---	---

**HIGH-STATIC BELT DRIVE — HORIZONTAL**

ESP (" H2O)	TURNS OPEN											
	0		1		2		3		4		5	
	CFM	BHP	CFM	BHP	CFM	BHP	CFM	BHP	CFM	BHP	CFM	BHP
0.6	---	---	---	---	---	---	---	---	---	---	---	---
0.7	---	---	---	---	---	---	---	---	---	---	---	---
0.8	---	---	---	---	---	---	---	---	---	---	1269	0.45
0.9	---	---	---	---	---	---	---	---	---	---	1150	0.44
1.0	---	---	---	---	---	---	---	---	1225	0.48	988	0.40
1.1	---	---	---	---	---	---	1280	0.55	1063	0.44	824	0.37
1.2	---	---	---	---	---	---	1143	0.52	867	0.40	---	---
1.3	---	---	---	---	1268	0.59	963	0.48	651	0.36	---	---
1.4	---	---	1332	0.68	1127	0.55	766	0.43	---	---	---	---
1.5	---	---	1198	0.64	986	0.52	---	---	---	---	---	---
1.6	1304	0.74	1013	0.59	833	0.48	---	---	---	---	---	---
1.7	1165	0.69	828	0.54	---	---	---	---	---	---	---	---
1.8	1075	0.67	---	---	---	---	---	---	---	---	---	---

Note: Tables represent dry coil without filter; to compensate for filter, add 0.08" to measured E.S.P. SCFM correction for wet coil = 4%.

STANDARD DIRECT DRIVE — HORIZONTAL

CFM	STATIC	AMPS	WATTS	RPM	SPEED TAP
1280	0.1	1.54	360	755	Low
1215	0.2	1.5	345	800	
1145	0.3	1.46	335	830	
1080	0.4	1.42	325	870	
1005	0.5	1.37	310	895	
1485	0.1	1.98	460	840	Med
1410	0.2	1.92	440	870	
1335	0.3	1.86	425	900	
1255	0.4	1.8	410	930	
1170	0.5	1.75	400	950	
1075	0.6	1.68	380	980	
945	0.7	1.6	360	1005	
1445	0.3	2.2	505	940	Med
1365	0.4	2.14	490	960	
1270	0.5	2.08	470	985	
1180	0.6	2.02	460	1000	
1050	0.7	1.92	435	1030	
825	0.8	1.78	400	1055	

STANDARD DIRECT DRIVE — DOWN SHOT

CFM	STATIC	AMPS	WATTS	RPM	SPEED TAP
1270	0.1	1.53	355	760	Low
1205	0.2	1.53	350	810	
1145	0.3	1.49	340	840	
1085	0.4	1.45	330	875	
1035	0.5	1.42	320	900	
1460	0.1	1.96	450	850	Med
1380	0.2	1.89	430	885	
1275	0.3	1.8	405	915	
1175	0.4	1.73	400	950	
1075	0.5	1.68	380	965	
1005	0.6	1.63	370	1000	
915	0.7	1.59	360	1015	
1445	0.3	2.2	500	950	High
1340	0.4	2.13	480	975	
1275	0.5	2.07	465	1000	
1175	0.6	2.02	455	1020	
1040	0.7	1.92	430	1045	
830	0.8	1.78	395	1070	

NOTE: Assumes dry coil with filter in place; SCFM correction for wet coil = 4%

AIRFLOW DATA — 4 TONS

STANDARD DIRECT DRIVE — HORIZONTAL

CFM	STATIC	AMPS	WATTS	RPM	SPEED TAP
1570	0.1	2.09	490	905	Low
1520	0.2	2.06	480	920	
1445	0.3	1.95	460	945	
1375	0.4	1.89	440	970	
1295	0.5	1.81	425	995	
1715	0.1	2.39	560	975	Med
1655	0.2	2.32	545	985	
1580	0.3	2.24	525	1005	
1500	0.4	2.16	505	1020	
1405	0.5	2.09	490	1035	
1305	0.6	2.00	465	1050	
1200	0.7	1.92	440	1065	
1839	0.1	2.77	650	1030	High
1770	0.2	2.70	630	1040	
1696	0.3	2.62	610	1050	
1611	0.4	2.53	590	1060	
1510	0.5	2.44	560	1070	
1418	0.6	2.36	540	1085	

STANDARD DIRECT DRIVE — DOWN SHOT

CFM	STATIC	AMPS	WATTS	RPM	SPEED TAP
1548	0.1	2.03	480	930	Low
1500	0.2	2	470	945	
1425	0.3	1.89	450	970	
1353	0.4	1.83	430	995	
1273	0.5	1.75	415	1020	
1660	0.1	2.31	540	1020	Med
1625	0.2	2.25	530	1035	
1565	0.3	2.19	515	1040	
1485	0.4	2.12	505	1050	
1405	0.5	2.12	500	1055	
1285	0.6	1.98	465	1060	
1200	0.7	1.93	440	1070	
1825	0.1	2.65	620	1045	High
1745	0.2	2.55	600	1060	
1670	0.3	2.53	590	1065	
1585	0.4	2.46	575	1070	
1480	0.5	2.37	550	1080	
1405	0.6	2.31	535	1090	

Note: Assumes dry coil with filter in place; SCFM correction for wet coil = 4%

**STANDARD BELT DRIVE — DOWN SHOT**

ESP (" H <sub>2</sub> O)	TURNS OPEN											
	0		1		2		3		4		5	
	CFM	BHP	CFM	BHP	CFM	BHP	CFM	BHP	CFM	BHP	CFM	BHP
0.1	---	---	---	---	---	---	---	---	1690	0.42	1553	0.33
0.2	---	---	---	---	---	---	1719	0.47	1548	0.39	1417	0.32
0.3	---	---	---	---	1699	0.50	1570	0.44	1406	0.37	1258	0.30
0.4	---	---	1742	0.53	1566	0.47	1421	0.41	1258	0.34	1095	0.27
0.5	1770	0.60	1617	0.50	1427	0.44	1278	0.38	1094	0.32	---	---
0.6	1664	0.57	1492	0.47	1286	0.41	1127	0.36	---	---	---	---
0.7	1558	0.54	1376	0.45	1139	0.38	935	0.32	---	---	---	---
0.8	1415	0.50	1220	0.41	961	0.35	---	---	---	---	---	---
0.9	1288	0.47	1054	0.38	---	---	---	---	---	---	---	---
1.0	1121	0.43	---	---	---	---	---	---	---	---	---	---
1.1	953	0.39	---	---	---	---	---	---	---	---	---	---

**HIGH-STATIC BELT DRIVE — DOWN SHOT**

ESP (" H <sub>2</sub> O)	TURNS OPEN											
	0		1		2		3		4		5	
	CFM	BHP	CFM	BHP	CFM	BHP	CFM	BHP	CFM	BHP	CFM	BHP
0.6	---	---	---	---	---	---	---	---	1688	0.58	1503	0.48
0.7	---	---	---	---	---	---	1716	0.62	1569	0.55	1398	0.46
0.8	---	---	---	---	---	---	1613	0.59	1450	0.51	1268	0.43
0.9	---	---	---	---	1702	0.67	1510	0.56	1331	0.48	1138	0.40
1.0	---	---	---	---	1589	0.64	1412	0.53	1190	0.45	984	0.37
1.1	---	---	1751	0.75	1477	0.60	1281	0.50	1052	0.42	---	---
1.2	1755	0.85	1605	0.70	1364	0.57	1133	0.46	---	---	---	---
1.3	1640	0.80	1459	0.66	1224	0.53	983	0.43	---	---	---	---
1.4	1525	0.76	1313	0.61	1083	0.49	---	---	---	---	---	---
1.5	1410	0.72	1192	0.57	---	---	---	---	---	---	---	---
1.6	1276	0.67	1033	0.53	---	---	---	---	---	---	---	---
1.7	1137	0.63	---	---	---	---	---	---	---	---	---	---
1.8	1008	0.59	---	---	---	---	---	---	---	---	---	---

Note: Tables represent dry coil without filter; to compensate for filter, add 0.08" to measured E.S.P. SCFM correction for wet coil = 4%.

**STANDARD BELT DRIVE — HORIZONTAL**

ESP (" H <sub>2</sub> O)	TURNS OPEN											
	0		1		2		3		4		5	
	CFM	BHP	CFM	BHP	CFM	BHP	CFM	BHP	CFM	BHP	CFM	BHP
0.1	---	---	---	---	---	---	---	---	---	---	1726	0.37
0.2	---	---	---	---	---	---	---	---	1720	0.43	1575	0.36
0.3	---	---	---	---	1888	0.57	1744	0.48	1562	0.41	1398	0.34
0.4	---	---	---	---	1740	0.54	1579	0.45	1398	0.38	1217	0.31
0.5	---	---	1797	0.56	1586	0.51	1420	0.42	1216	0.36	1004	0.28
0.6	1849	0.62	1658	0.53	1429	0.48	1252	0.40	997	0.32	---	---
0.7	1731	0.59	1528	0.51	1266	0.45	1039	0.36	---	---	---	---
0.8	1572	0.55	1355	0.47	1068	0.41	---	---	---	---	---	---
0.9	1431	0.52	1171	0.43	---	---	---	---	---	---	---	---
1.0	1245	0.48	987	0.39	---	---	---	---	---	---	---	---
1.1	1059	0.44	---	---	---	---	---	---	---	---	---	---

**HIGH-STATIC BELT DRIVE — HORIZONTAL**

ESP (" H <sub>2</sub> O)	TURNS OPEN											
	0		1		2		3		4		5	
	CFM	BHP	CFM	BHP	CFM	BHP	CFM	BHP	CFM	BHP	CFM	BHP
0.6	---	---	---	---	---	---	---	---	---	---	1669	0.53
0.7	---	---	---	---	---	---	---	---	1741	0.61	1553	0.51
0.8	---	---	---	---	---	---	1792	0.66	1610	0.57	1408	0.48
0.9	---	---	---	---	---	---	1680	0.63	1479	0.53	1264	0.44
1.0	---	---	---	---	1765	0.71	1568	0.59	1323	0.50	1093	0.41
1.1	---	---	---	---	1640	0.67	1422	0.55	1168	0.46	---	---
1.2	---	---	1784	0.78	1515	0.64	1259	0.51	995	0.43	---	---
1.3	1821	0.89	1621	0.73	1360	0.59	1091	0.47	---	---	---	---
1.4	1694	0.84	1458	0.68	1202	0.55	---	---	---	---	---	---
1.5	1567	0.80	1324	0.63	1042	0.51	---	---	---	---	---	---
1.6	1417	0.75	1148	0.59	---	---	---	---	---	---	---	---
1.7	1262	0.70	---	---	---	---	---	---	---	---	---	---
1.8	1120	0.66	---	---	---	---	---	---	---	---	---	---

Note: Tables represent dry coil without filter; to compensate for filter, add 0.08" to measured E.S.P. SCFM correction for wet coil = 4%.

STANDARD DIRECT-DRIVE — HORIZONTAL

CFM	STATIC	AMPS	WATTS	RPM	SPEED TAP
1215	0.1	1.4	165	610	T1
1150	0.2	1.46	175	645	
1085	0.3	1.54	180	690	
1010	0.4	1.64	195	725	
900	0.5	1.74	205	780	
840	0.6	1.77	215	810	
1395	0.1	1.86	230	670	T2
1325	0.2	1.95	240	705	
1260	0.3	2.01	250	735	
1210	0.4	2.10	260	770	
1135	0.5	2.16	265	810	
1040	0.6	2.28	280	860	
970	0.7	2.38	290	885	
910	0.8	2.46	300	925	
840	0.9	2.52	310	955	
1790	0.1	3.24	425	810	T3
1735	0.2	3.37	435	830	
1670	0.3	3.45	450	865	
1610	0.4	3.55	465	890	
1560	0.5	3.60	475	920	
1520	0.6	3.70	490	945	
1470	0.7	3.80	500	970	
1410	0.8	3.94	510	995	
1345	0.9	3.98	530	1035	
2005	0.1	4.30	575	880	T4
1965	0.2	4.41	590	900	
1895	0.3	4.52	610	930	
1835	0.4	4.63	620	955	
1790	0.5	4.75	635	980	
1745	0.6	4.84	650	1005	
1695	0.7	4.91	660	1030	
1650	0.8	5.03	675	1055	
1600	0.9	5.10	675	1080	
2120	0.1	5.10	690	930	T5
2075	0.2	5.15	710	950	
2025	0.3	5.23	720	975	
1975	0.4	5.35	735	995	
1930	0.5	5.46	750	1020	
1875	0.6	5.59	770	1040	
1835	0.7	5.64	780	1065	
1795	0.8	5.73	790	1090	
1735	0.9	5.82	805	1110	

STANDARD DIRECT-DRIVE — DOWN SHOT

CFM	STATIC	AMPS	WATTS	RPM	SPEED TAP
1205	0.1	1.47	180	635	T1
1150	0.2	1.54	185	675	
1065	0.3	1.59	185	730	
980	0.4	1.68	195	760	
860	0.5	1.79	200	810	
800	0.6	1.82	220	840	
1375	0.1	1.94	235	690	T2
1300	0.2	2.01	245	720	
1230	0.3	2.05	255	750	
1180	0.4	2.15	265	790	
1100	0.5	2.22	275	830	
1005	0.6	2.33	285	890	
970	0.7	2.43	295	900	
915	0.8	2.51	310	940	
845	0.9	2.57	315	980	
1755	0.1	3.34	385	850	T3
1700	0.2	3.47	395	865	
1665	0.3	3.56	410	895	
1580	0.4	3.68	425	930	
1545	0.5	3.72	435	955	
1505	0.6	3.80	520	990	
1430	0.7	3.93	530	1020	
1370	0.8	4.08	535	1040	
1300	0.9	4.12	570	1070	
1945	0.1	4.46	600	920	T4
1910	0.2	4.57	620	940	
1850	0.3	4.66	635	965	
1795	0.4	4.78	655	990	
1760	0.5	4.84	670	1020	
1710	0.6	4.96	685	1045	
1640	0.7	5.06	675	1065	
1610	0.8	5.19	690	1090	
1560	0.9	5.22	700	1125	
2090	0.1	5.35	720	970	T5
2040	0.2	5.38	740	990	
1985	0.3	5.70	755	1025	
1935	0.4	5.44	760	1035	
1900	0.5	5.82	780	1050	
1855	0.6	5.73	800	1075	
1810	0.7	5.69	810	1090	
1750	0.8	5.82	825	1120	
1680	0.9	5.94	840	1145	

NOTES

- Assumes dry coil with filter in place; SCFM correction for wet coil = 4%
- Five-ton models are shipped from the factory with speed tap set on T4.



**STANDARD BELT DRIVE — DOWN SHOT**

ESP (" H <sub>2</sub> O)	TURNS OPEN											
	0		1		2		3		4		5	
	CFM	BHP	CFM	BHP	CFM	BHP	CFM	BHP	CFM	BHP	CFM	BHP
0.1	---	---	---	---	2071	0.62	1972	0.54	1816	0.41	1668	0.34
0.2	---	---	2180	0.70	1977	0.59	1846	0.51	1699	0.39	1533	0.33
0.3	2110	0.79	2066	0.66	1873	0.56	1721	0.47	1572	0.35	1387	0.30
0.4	2024	0.76	1950	0.63	1769	0.53	1596	0.44	1443	0.33	1247	0.27
0.5	1937	0.73	1833	0.60	1643	0.50	1554	0.41	1302	0.30	---	---
0.6	1851	0.69	1716	0.56	1523	0.46	1330	0.38	---	---	---	---
0.7	1764	0.65	1601	0.53	1393	0.42	1186	0.34	---	---	---	---
0.8	1653	0.61	1477	0.49	1256	0.39	---	---	---	---	---	---
0.9	1534	0.57	1350	0.45	---	---	---	---	---	---	---	---
1.0	1411	0.53	1180	0.40	---	---	---	---	---	---	---	---
1.1	1270	0.49	---	---	---	---	---	---	---	---	---	---

**HIGH-STATIC BELT DRIVE — DOWN SHOT**

ESP (" H <sub>2</sub> O)	TURNS OPEN											
	0		1		2		3		4		5	
	CFM	BHP	CFM	BHP	CFM	BHP	CFM	BHP	CFM	BHP	CFM	BHP
0.6	---	---	---	---	---	---	---	---	2227	0.86	2050	0.73
0.7	---	---	---	---	---	---	---	---	2102	0.82	1932	0.69
0.8	---	---	---	---	---	---	2274	0.93	1999	0.79	1820	0.67
0.9	---	---	---	---	2304	1.03	2130	0.88	1859	0.76	1630	0.63
1.0	---	---	---	---	2162	0.98	2010	0.86	1694	0.72	1487	0.59
1.1	---	---	2325	1.15	2027	0.94	1820	0.79	1543	0.68	1267	0.55
1.2	2355	1.26	2247	1.11	1902	0.90	1721	0.77	1331	0.63	---	---
1.3	2247	1.22	2062	1.05	1768	0.87	1557	0.71	---	---	---	---
1.4	2151	1.19	1932	1.01	1579	0.82	1374	0.66	---	---	---	---
1.5	2004	1.14	1768	0.95	1339	0.74	---	---	---	---	---	---
1.6	1895	1.10	1637	0.91	---	---	---	---	---	---	---	---
1.7	1727	1.04	1331	0.80	---	---	---	---	---	---	---	---
1.8	1391	0.92	---	---	---	---	---	---	---	---	---	---

Note: Tables represent dry coil without filter; to compensate for filter, add 0.08" to measured E.S.P. SCFM correction for wet coil = 4%.

**STANDARD BELT DRIVE — HORIZONTAL**

ESP (" H <sub>2</sub> O)	TURNS OPEN											
	0		1		2		3		4		5	
	CFM	BHP	CFM	BHP	CFM	BHP	CFM	BHP	CFM	BHP	CFM	BHP
0.1	---	---	---	---	---	---	---	---	2105	0.49	1940	0.40
0.2	---	---	---	---	---	---	2147	0.57	1975	0.47	1782	0.39
0.3	---	---	---	---	2178	0.63	2001	0.53	1828	0.43	1613	0.36
0.4	---	---	---	---	2057	0.60	1855	0.50	1678	0.41	1450	0.33
0.5	---	---	2131	0.68	1910	0.57	1691	0.47	1515	0.38	1252	0.29
0.6	2152	0.78	1995	0.64	1771	0.53	1546	0.44	1320	0.34	---	---
0.7	2051	0.74	1862	0.61	1620	0.49	1379	0.40	---	---	---	---
0.8	1922	0.70	1718	0.57	1461	0.46	1202	0.37	---	---	---	---
0.9	1784	0.66	1570	0.53	1296	0.43	---	---	---	---	---	---
1.0	1641	0.62	1371	0.48	---	---	---	---	---	---	---	---
1.1	1477	0.58	1200	0.44	---	---	---	---	---	---	---	---
1.2	1292	0.53	---	---	---	---	---	---	---	---	---	---

**HIGH-STATIC BELT DRIVE — HORIZONTAL**

ESP (" H <sub>2</sub> O)	TURNS OPEN											
	0		1		2		3		4		5	
	CFM	BHP	CFM	BHP	CFM	BHP	CFM	BHP	CFM	BHP	CFM	BHP
0.6	---	---	---	---	---	---	---	---	2164	0.89	1985	0.76
0.7	---	---	---	---	---	---	2232	0.99	2047	0.85	1858	0.72
0.8	---	---	---	---	---	---	2104	0.95	1943	0.82	1735	0.70
0.9	---	---	---	---	2200	1.09	1995	0.92	1819	0.79	1603	0.67
1.0	---	---	2297	1.22	2086	1.06	1900	0.89	1687	0.75	1410	0.62
1.1	---	---	2204	1.19	1995	1.02	1774	0.86	1543	0.71	---	---
1.2	2249	1.32	2101	1.15	1875	0.99	1624	0.81	1352	0.66	---	---
1.3	2175	1.28	1958	1.11	1740	0.94	1482	0.77	---	---	---	---
1.4	2072	1.25	1836	1.06	1587	0.89	1308	0.72	---	---	---	---
1.5	1945	1.20	1685	1.00	1402	0.83	---	---	---	---	---	---
1.6	1841	1.15	1519	0.94	---	---	---	---	---	---	---	---
1.7	1684	1.09	---	---	---	---	---	---	---	---	---	---
1.8	1541	1.03	---	---	---	---	---	---	---	---	---	---

**AIR FLOW PRESSURE DROP OF DOWN FLOW ECONOMIZER**

AIRFLOW PRESSURE DROP OF DOWNFLOW ECONOMIZER FOR 3 TO 6 TON ROFTOP UNITS (100% RETURN AIR)											
SCF,	800	1000	1200	1400	1600	1800	2000	2200	2400	2600	2800
in WG	0.02	0.04	0.05	0.07	0.09	0.12	0.14	0.17	0.21	0.24	0.28

HIGH EFFICIENCY MERV 13 AIR FILTER OPTION

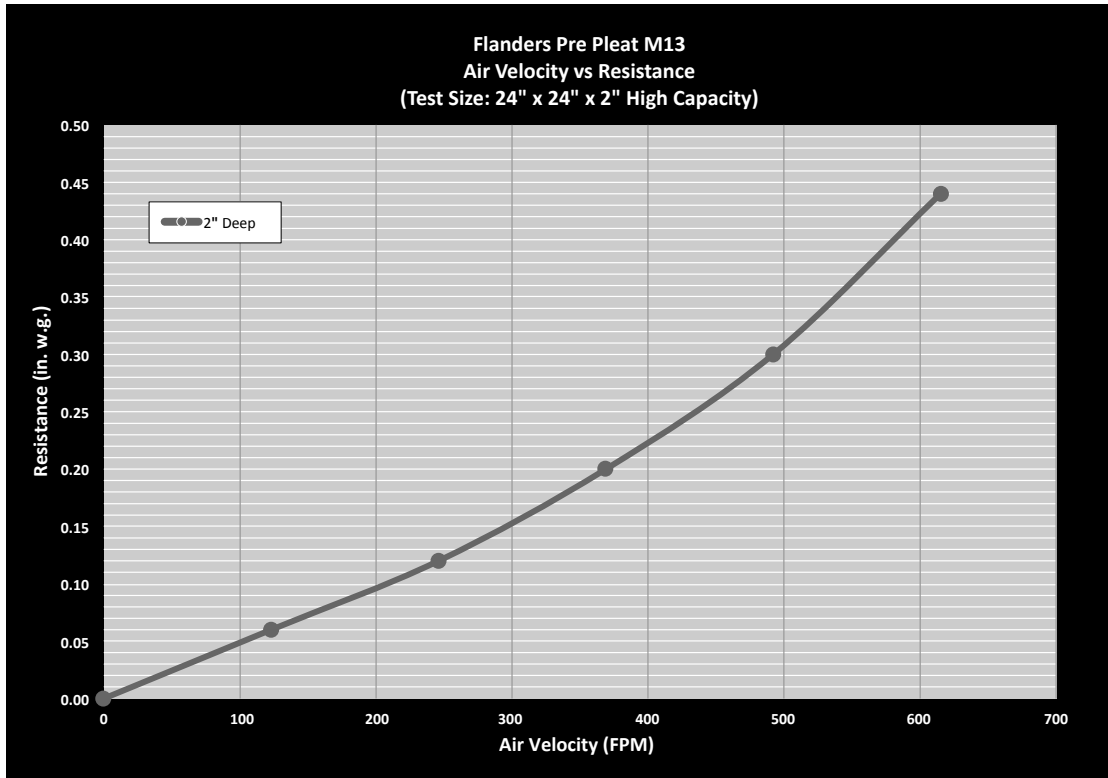

TONNAGE:	FILTER NOMINAL SIZE:	PART NUMBER:	ORDER QTY:
3	24 x 24 x 2	0160L00203	1
4	14 x 20 x 2	0160L00204	4
5	16 x 20 x 2	0160L00205	4

CRANKCASE HEATER SELECTION TABLE

ZP/ZPS...	COMPRESSOR DIAMETER	COMPRESSOR VOLTAGE			CRANKCASE HEATER WATTS
		230V	460V	575V	
16-31	5.5"	0163R00002S	0163R00031S	0163R00032S	40
39-83	6.58/7.3"	0130L00017S	0130L00018S	0130L00019S	70
103-137	9.14"	0130L00020S	0130L00021S	0130L00022S	90

DC*,DT* & DS* TONNAGE	COMPRESSOR VOLTAGE			CRANKCASE HEATER WATTS
	230V	460V	575V	
3 Ton	0163R00002S	0163R00031S	0163R00032S	40
4 Ton-5 Ton	0130L00017S	0130L00018S	0130L00019S	70

\*Includes C,G&H models.

## 3 TONS

MODEL NUMBER	ELECTRICAL RATING	COMPRESSOR CIRCUIT 1		COMPRESSOR CIRCUIT 2		OUTDOOR FAN MOTOR			INDOOR FAN MOTOR			OPTIONAL POWERED CONVENIENCE OUTLET	POWER SUPPLY	
		RLA	LRA	RLA	LRA	QTY	HP	FLA	TYPE	HP	FLA	FLA	MCA	MOP
DSG036XXX1D	208/230-1-60	16.7	79.0			1	0.25	1.40	Standard - Direct Drive	0.33	2.46	- 7.2 / 6.5	24.7 / 24.7 31.9 / 31.2	40 / 40 45 / 45
DSG036XXX3B	208/230-3-60	10.4	73.0			1	0.25	1.40	Standard - Direct Drive	1.50	3.40	- 7.2 / 6.5	16.9 / 16.9 24.1 / 23.4	25 / 25 30 / 30
DSG036XXX3D	208/230-3-60	10.4	73.0			1	0.25	1.40	Standard - Belt Drive	0.33	2.46	- 7.2 / 6.5	17.9 / 17.9 25.1 / 24.4	25 / 25 35 / 30
DSG036XXX3H	208/230-3-60	10.4	73.0			1	0.25	1.40	High Static - Belt Drive	1.50	4.60	- 7.2 / 6.5	19.1 / 19.1 26.3 / 25.6	25 / 25 35 / 35
DSG036XXX4B	460-3-60	5.8	38.0			1	0.25	0.70	Standard - Belt Drive	1.00	1.70	- 3.3	9.6 12.9	15 15
DSG036XXX4H	460-3-60	5.8	38.0			1	0.25	0.70	High Static - Belt Drive	1.50	2.10	- 3.3	10.0 13.3	15 15
DSG036XXX7B	575-3-60	3.8	36.5			1	0.25	0.55	Standard - Belt Drive	1.50	2.30	- 2.6	7.6 10.2	15 15

## 4 TONS

MODEL NUMBER	ELECTRICAL RATING	COMPRESSOR CIRCUIT 1		COMPRESSOR CIRCUIT 2		OUTDOOR FAN MOTOR			INDOOR FAN MOTOR			OPTIONAL POWERED CONVENIENCE OUTLET	POWER SUPPLY	
		RLA	LRA	RLA	LRA	QTY	HP	FLA	TYPE	HP	FLA	FLA	MCA	MOP
DSG048XXX1D	208/230-1-60	19.9	109.0			1	0.25	1.40	Standard - Direct Drive	0.75	2.80	- 7.2 / 6.5	29.0 / 29.0 36.2 / 35.5	45 / 45 50 / 50
DSG048XXX3D	208/230-3-60	13.1	83.0			1	0.25	1.40	Standard - Direct Drive	0.75	2.80	- 7.2 / 6.5	20.6 / 20.6 27.8 / 27.1	30 / 30 40 / 40
DSG048XXX3B	208/230-3-60	13.1	83.1			1	0.25	1.40	Standard - Belt Drive	1.00	3.40	- 7.2 / 6.5	21.2 / 21.2 28.4 / 27.7	30 / 30 40 / 40
DSG048XXX3H	208/230-3-60	13.1	83.1			1	0.25	1.40	High Static - Belt Drive	1.50	4.60	- 7.2 / 6.5	22.4 / 22.4 29.6 / 28.9	35 / 35 40 / 40
DSG048XXX4B	460-3-60	6.1	41.0			1	0.25	0.70	Standard - Belt Drive	1.00	1.70	- 3.3	10.0 13.3	15 15
DSG048XXX4H	460-3-60	6.1	41.0			1	0.25	0.70	High Static - Belt Drive	1.50	2.10	- 3.3	10.4 13.7	15 15
DSG048XXX7B	575-3-60	4.4	33.0			1	0.25	0.55	Standard - Belt Drive	1.50	2.30	- 2.6	8.3 10.9	15 15

## 5 TONS

MODEL NUMBER	ELECTRICAL RATING	COMPRESSOR CIRCUIT 1		COMPRESSOR CIRCUIT 2		OUTDOOR FAN MOTOR			INDOOR FAN MOTOR			OPTIONAL POWERED CONVENIENCE OUTLET	POWER SUPPLY	
		RLA	LRA	RLA	LRA	QTY	HP	FLA	TYPE	HP	FLA	FLA	MCA	MOP
DSG060XXX1D	208/230-1-60	26.4	134.0			1	0.25	1.40	Standard - Direct Drive	1.00	6.90	- 7.2 / 6.5	41.3 / 41.3 48.5 / 47.8	60 / 60 70 / 70
DSG060XXX3D	208/230-3-60	16.0	110.0			1	0.25	1.40	Standard - Direct Drive	1.00	6.90	- 7.2 / 6.5	28.3 / 28.3 35.5 / 34.8	40 / 40 50 / 50
DSG060XXX3B	208/230-3-60	16.0	110.0			1	0.25	1.40	Standard - Belt Drive	1.00	3.20	- 7.2 / 6.5	24.6 / 24.6 31.8 / 31.1	40 / 40 45 / 45
DSG060XXX3H	208/230-3-60	16.0	110.0			1	0.25	1.40	High Static - Belt Drive	1.50	4.80	- 7.2 / 6.5	26.2 / 26.2 33.4 / 32.7	40 / 40 45 / 45
DSG060XXX4B	460-3-60	7.8	52.0			1	0.25	0.70	Standard - Belt Drive	1.00	1.50	- 3.3	11.9 15.2	15 20
DSG060XXX4H	460-3-60	7.8	52.0			1	0.25	0.70	High Static - Belt Drive	1.50	2.40	- 3.3	12.8 16.1	20 20
DSG060XXX7B	575-3-60	5.7	38.9			1	0.25	0.55	Standard - Belt Drive	1.00	1.20	- 2.6	8.9 11.5	15 15

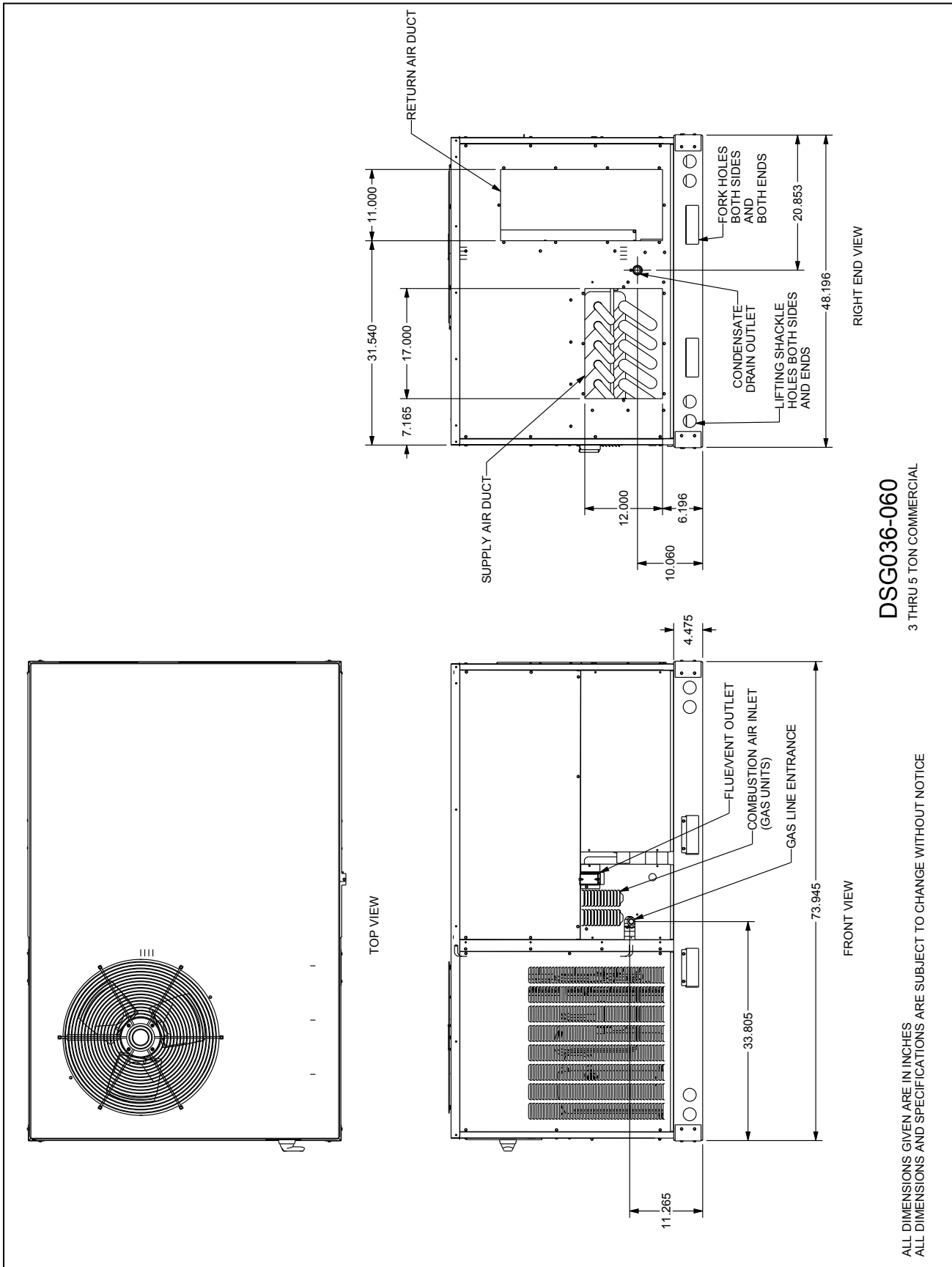

**DSG036-060**  
3 THRU 5 TON COMMERCIAL

ALL DIMENSIONS GIVEN ARE IN INCHES  
ALL DIMENSIONS AND SPECIFICATIONS ARE SUBJECT TO CHANGE WITHOUT NOTICE

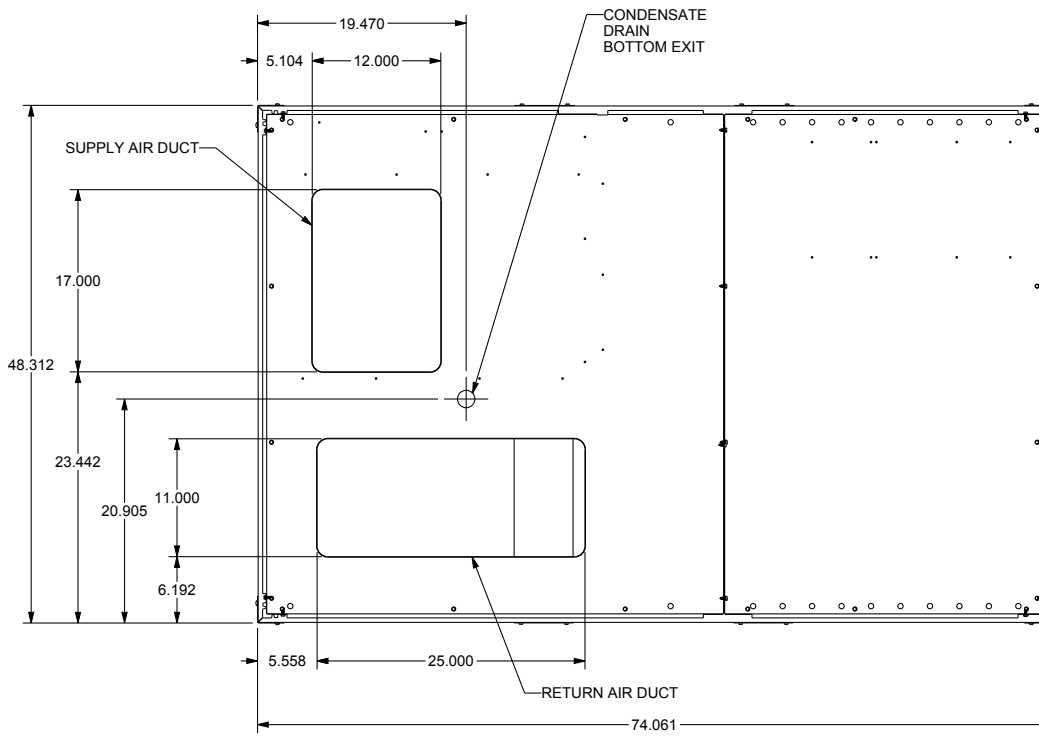

BASE PAN VIEW  
(VIEWED FROM TOP)

MODEL TONNAGES	"A"	"B"	"C"
3 TON COMMERCIAL GAS, HT PUMP, AIR CONDITIONER	38.840	16.555	26.055
4 TON COMMERCIAL GAS, HT PUMP, AIR CONDITIONER	38.840	16.555	26.055
5 TON COMMERCIAL GAS, AIR CONDITIONER	38.840	16.555	26.055
5 TON COMMERCIAL HT PUMP	42.840	20.555	30.055

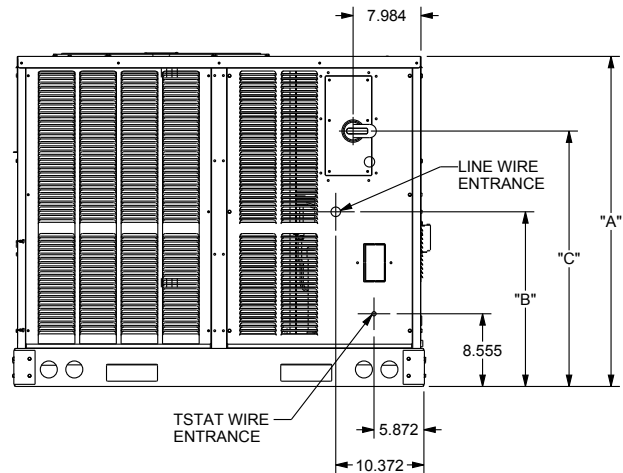

LEFT END VIEW

Maintain an adequate clearance around the unit for safety, service, maintenance, and proper unit operation. Leave a clearance of 48" on all sides of the unit for possible compressor removal or service access, and to ensure proper ventilation and condenser airflow. Do not install the unit beneath any obstruction. Install the unit away from all building exhausts to inhibit ingestion of exhaust air into the unit's fresh-air intake.

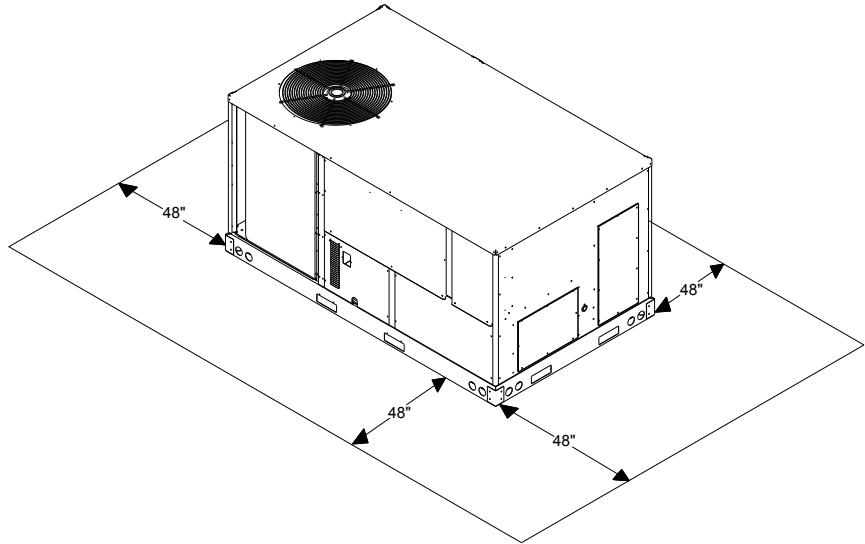

**ELECTRICAL ENTRANCE LOCATIONS**

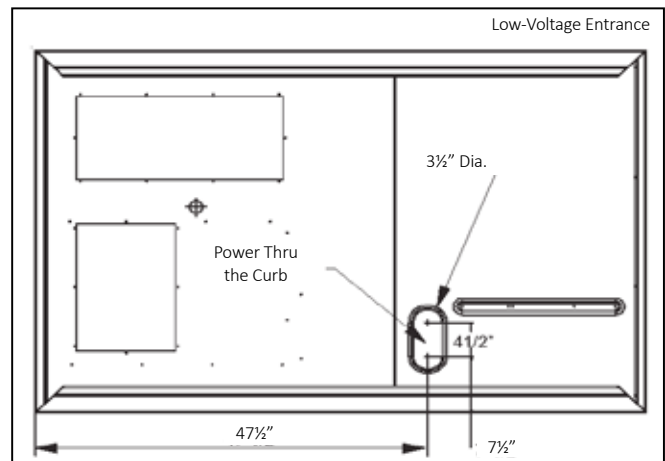
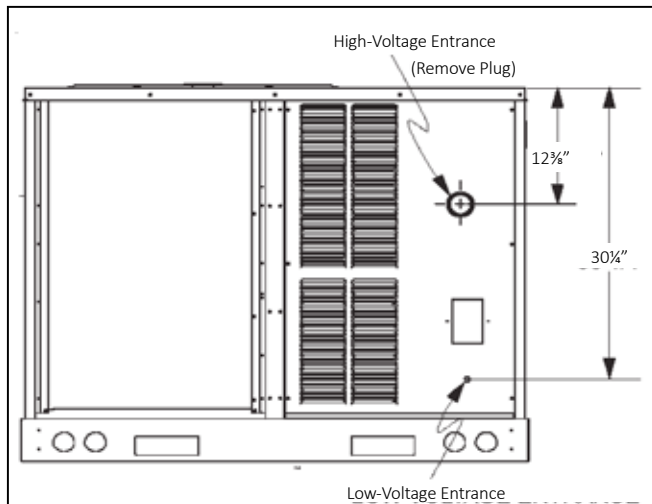

**CORNER & CENTER-OF-GRAVITY LOCATIONS**

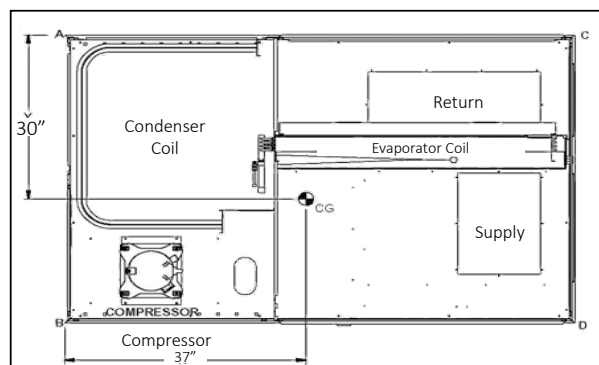

UNIT WEIGHTS	3-TON WEIGHTS	4-TON WEIGHTS	5-TON WEIGHTS
Corner Weight (A)	109	113	113
Corner Weight (B)	178	192	194
Corner Weight (C)	109	118	119
Corner Weight (D)	179	192	194
Unit Shipping Weight	600	615	620
Unit Operating Weight	575	640	645

**Note:** Weights are calculated without accessories installed.

Provisions for forks have been included in the unit base frame. No other fork locations are approved.

- Unit must be lifted by the four lifting holes located at the base frame corners.
- Lifting cables should be attached to the unit with shackles.
- The distance between the crane hook and the top of the unit must not be less than 60".
- Two spreader bars must span over the unit to prevent damage to the cabinet by the lift cables. Spreader bars must be of sufficient length so that cables do not come in contact with the unit during transport. Remove wood struts mounted beneath unit base frame before setting unit on roof curb. These struts are intended to protect unit base frame from fork lift damage. To remove the struts, extract the sheet metal retainers and pull the struts through the base of the unit. Refer to rigging label on the unit.

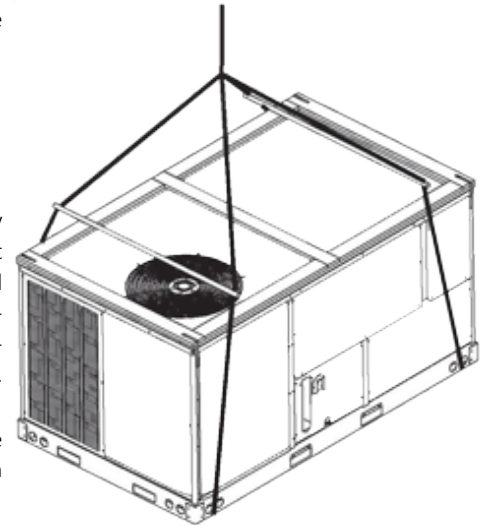

**Important:** If using bottom discharge with roof curb, duct-work should be attached to the curb prior to installing the unit. Duct-work dimensions are shown in Roof Curb Installation Instructions Manual.

Refer to the Roof Curb Installation Instructions for proper curb installation. Curbing must be installed in compliance with the National Roofing Contractors Association Manual.

Lower unit carefully onto roof mounting curb. While rigging the unit, the center of gravity will cause the condenser end to be lower than the supply air end.

Bring condenser end of unit into alignment with the curb. With condenser end of the unit resting on curb member and using curb as a fulcrum, lower opposite end of the unit until entire unit is seated on the curb. When a rectangular cantilever curb is used, take care to center the unit. Check for proper alignment and orientation of supply and return openings with duct.

To assist in determining rigging requirements, unit weights are shown below.

Curb installations must comply with local codes and should follow the established guidelines of the National Roofing Contractors Association.

Proper unit installation requires that the roof curb be firmly and permanently attached to the roof structure. Check for adequate fastening method prior to setting the unit on the curb.

Full perimeter roof curbs are available from the factory and are shipped unassembled. The installing contractor is responsible for field assembly, squaring, leveling, and mounting on the roof structure. All required hardware necessary for the assembly of the sheet metal curb is included in the curb accessory package.

- Determine sufficient structural support before locating and mounting the curb and package unit.
- Duct-work must be constructed using industry guidelines. The duct-work must be placed into the roof curb before mounting the package unit. Our full perimeter curbs include duct connection frames to be assembled with the curb. Cantilevered-type curbs are not available from the factory.
- Contractor furnishes curb insulation, cant strips, flashing, and general roofing material.
- Support curbs on parallel sides with roof members. To prevent damage to the unit, the roof members cannot penetrate supply and return duct openings.

**Note:** The unit and curb accessories are designed to allow vertical duct installation before unit placement. Duct installation after unit placement is not recommended.

See the manual shipped with the roof curb for assembly and installation instructions.

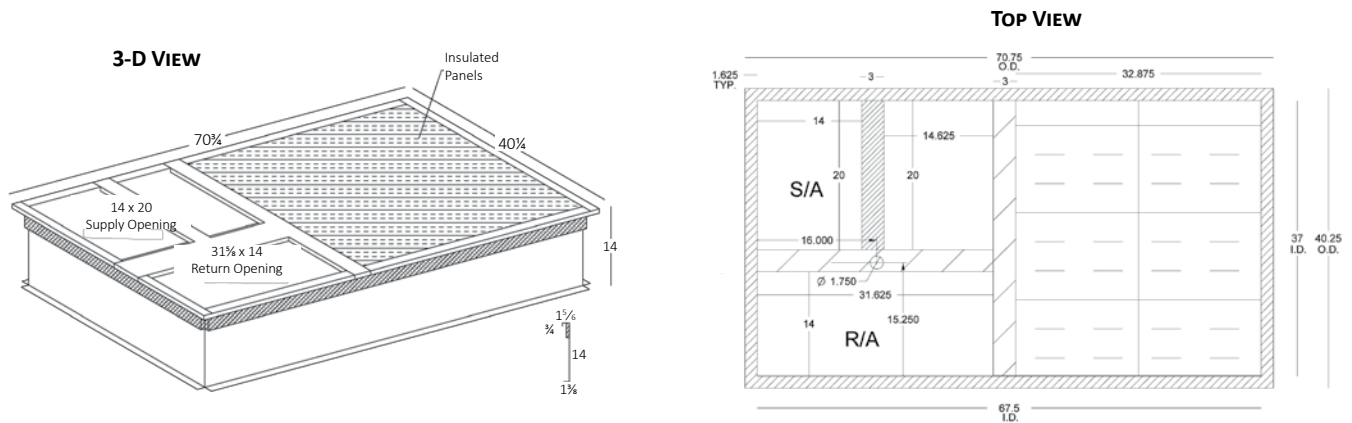



0140L02898-B

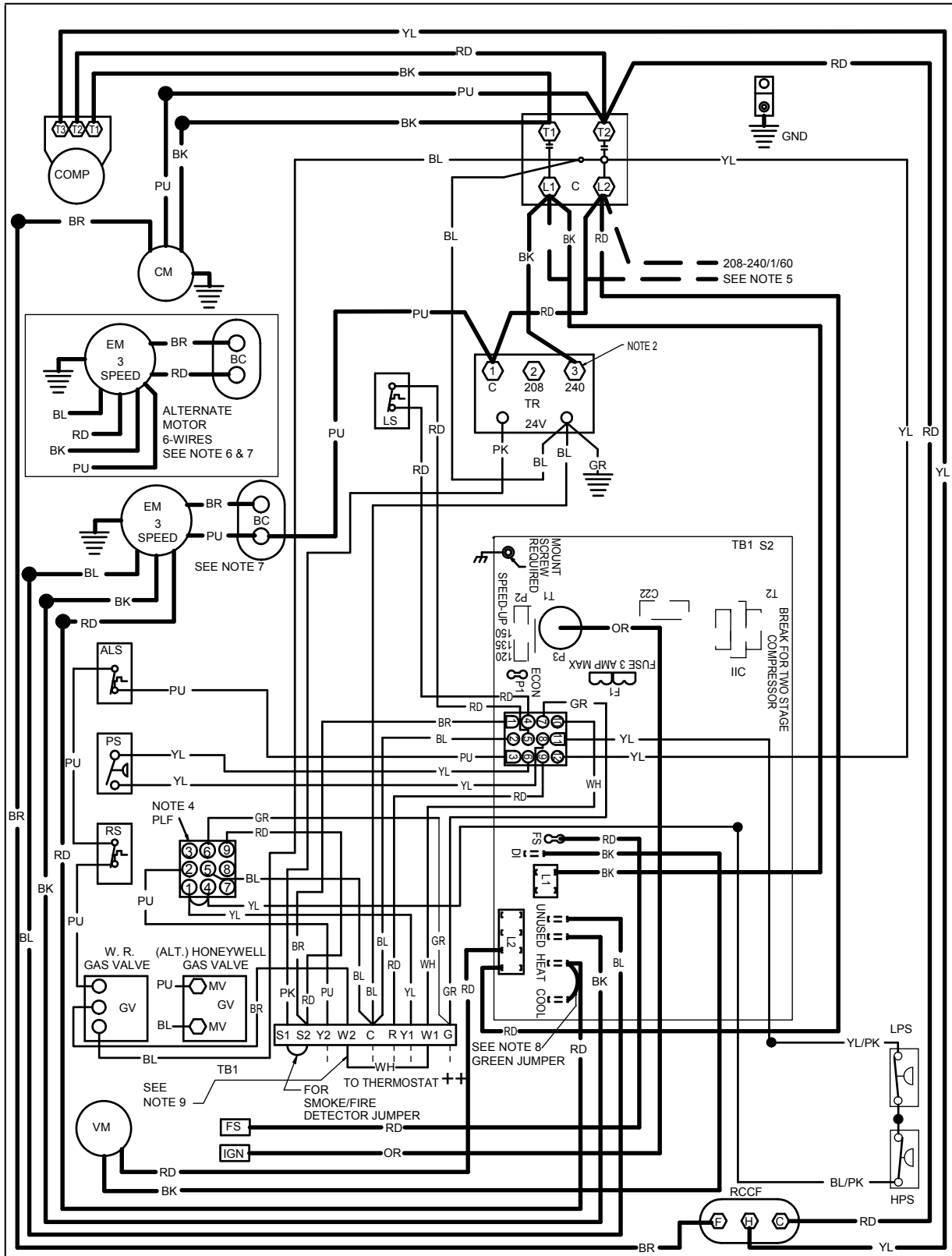

**High Voltage:** Disconnect all power before servicing or installing this unit. Multiple power sources may be present. Failure to do so may cause property damage, personal injury, or death.

**WARNING**

Wiring is subject to change. Always refer to the wiring diagram on the unit for the most up-to-date wiring.

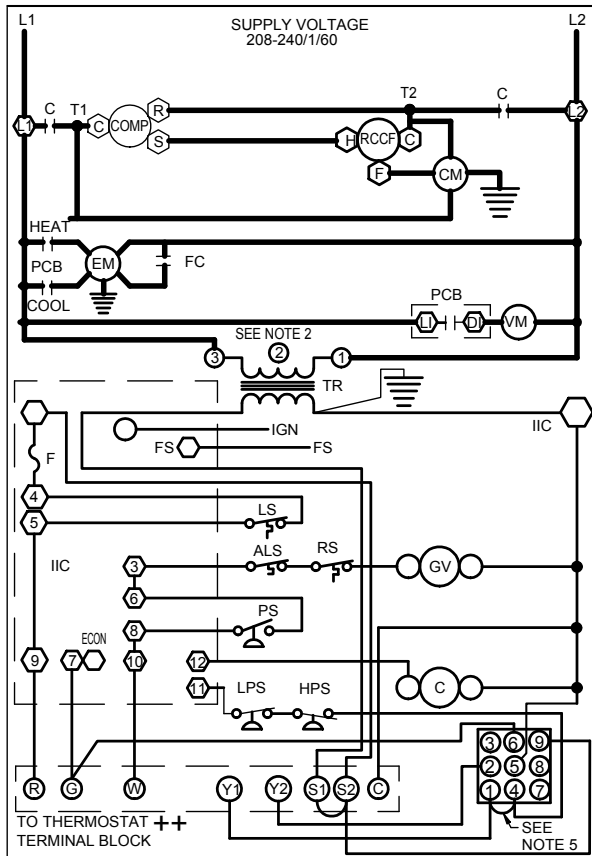

- COMPONENT LEGEND**
- ALS AUXILIARY LIMIT SWITCH
  - COMP COMPRESSOR
  - CM CONDENSER MOTOR
  - C CONTACTOR
  - EM EVAPORATOR MOTOR
  - F FUSE
  - FS FLAME SENSOR
  - GND EQUIPMENT GROUND
  - GV GAS VALVE
  - HPS HIGH PRESSURE SWITCH
  - IIC INTEGRATED IGNITION CONTROL
  - IGN IGNITOR
  - LS LIMIT SWITCH
  - LPS LOW PRESSURE SWITCH
  - PLF FEMALE PLUG/CONNECTOR
  - RCCF RUN CAPACITOR FOR CONDENSER FAN
  - PS PRESSURE SWITCH
  - RS ROLLOUT SWITCH
  - TB1 TERMINAL BLOCK (24V SIGNAL)
  - TR TRANSFORMER
  - VM VENT MOTOR
  - VMR VENT MOTOR RELAY
  - BC BLOWER CAPACITOR

- NOTES**
1. REPLACEMENT WIRE MUST BE THE SAME SIZE AND TYPE OF INSULATION AS ORIGINAL. (USE COPPER CONDUCTOR ONLY).
  2. FOR 208 VOLT TRANSFORMER OPERATION MOVE BLACK WIRE FROM TERMINAL 3 TO TERMINAL 2 ON TRANSFORMER.
  3. FOR DIFFERENT THAN FACTORY SPEED TAP. CHANGE COOLING SPEED AT COOL TERMINAL. CHANGE HEATING SPEED AT HEAT TERMINAL ON CONTROL BOARD 3 SPEED MOTOR
  - RD - LOW SPEED  
BK - HIGH SPEED  
BL - MED. SPEED
  4. ACCESSORY ECONOMIZER PLUG ADJACENT TO BLOWER HOUSING IN RETURN AIR COMPARTMENT. REMOVE MALE PLUG AND ATTACH FEMALE PLUG TO ECONOMIZER ACCESSORY.
  5. USE COPPER CONDUCTORS ONLY.  
++ USE NEC CLASS 2 WIRE.
  6. PURPLE WIRE CONNECTS TO TRANSFORMER (PIN 1).
  7. SPEED TAP TERMINATIONS SHOWN ON DIAGRAM ARE REPRESENTATIVE, BUT ACTUAL FACTORY SETTING MAY BE DIFFERENT BASED ON HEATING VALUE AND CAPACITY OF UNIT.
  8. TO RUN DIFFERENT SPEED FOR HEATING AND COOLING. DISCONNECT GREEN JUMPER FROM "COOL" TERMINAL AND REPLACE WITH APPROPRIATE SPEED TAP. THEN PLACE DISCONNECTED END OF JUMPER ON "UNUSED" TERMINAL LEFT OPEN BY MOVING THE SPEED TAP.
  9. FOR LOW STAGE OPERATION ONLY. REMOVE WHITE JUMPER. FOR 2 STAGE OPERATION, REMOVE JUMPER AND CONNECT W2 TO W1 ON THERMOSTAT. SEE UNIT RATING PLATE FOR TYPE AND SIZE OF OVERCURRENT PROTECTION.

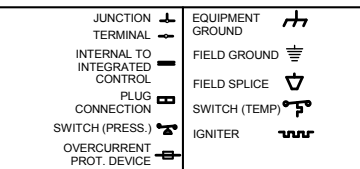

- FACTORY WIRING**
- Solid line: LINE VOLTAGE
  - Thin solid line: LOW VOLTAGE
  - Dashed line: OPTIONAL
  - Thick dashed line: HIGH VOLTAGE
  - Thin dashed line: OPTIONAL
  - Thin solid line: LOW VOLTAGE
- FIELD WIRING**
- Thick dashed line: HIGH VOLTAGE
  - Thin dashed line: LOW VOLTAGE
- WIRE CODE**
- BK BLACK
  - BL BLUE
  - BR BROWN
  - GR GREEN
  - OR ORANGE
  - PK PINK
  - PU PURPLE
  - RD RED
  - WH WHITE
  - YL YELLOW
  - BL/PK BLUE WITH PINK STRIP
  - YL/PK YELLOW WITH PINK STRIP

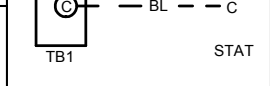
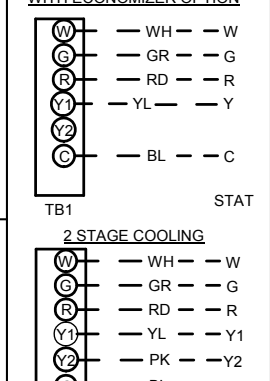
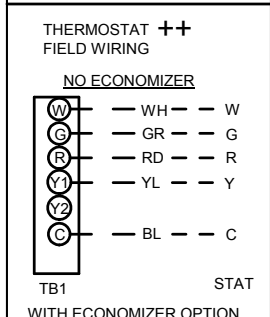

**INSTALLER/SERVICEMAN**  
THE STATUS LIGHT ON THE FURNACE CONTROL MAY BE USED AS A GUIDE TO TROUBLESHOOTING THIS APPLIANCE. STATUS LIGHT CODES ARE AS FOLLOWS:

STATUS LIGHT	EQUIP. STATUS	CHECK
ON	NORMAL OPERATION	-
OFF	NO POWER OR INTERNAL CONTROL	CHECK INPUT POWER CHECK FUSE ON CONTROL REPLACE CONTROL
1 BLINK	IGNITION FAILURE OR OPEN ROLLOUT SWITCH OR OPEN AUX. LIMIT SWITCH	GAS FLOW GAS PRESSURE GAS VALVE FLAME SENSOR FLAME ROLLOUT BAD SWITCH AUX. LIMIT OPEN
2 BLINKS	PRESSURE SWITCH OPEN	CHECK PRESSURE SWITCH
3 BLINKS	PRESSURE SWITCH CLOSED WITHOUT INDUCER ON	CHECK PRESSURE SWITCH
4 BLINKS	OPEN LIMIT SWITCH	MAIN LIMIT OPEN BAD SWITCH
5 BLINKS	FALSE FLAME SENSED	STICKING GAS VALVE
6 BLINKS	COMPRESSOR OUTPUT DELAY	3 MIN. COMP. ANTI-CYCLE TIMER

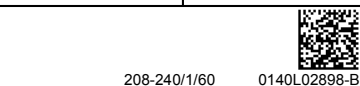

**High Voltage:** Disconnect all power before servicing or installing this unit. Multiple power sources may be present. Failure to do so may cause property damage, personal injury, or death.

**WARNING**

Wiring is subject to change. Always refer to the wiring diagram on the unit for the most up-to-date wiring.

0140L02900-B

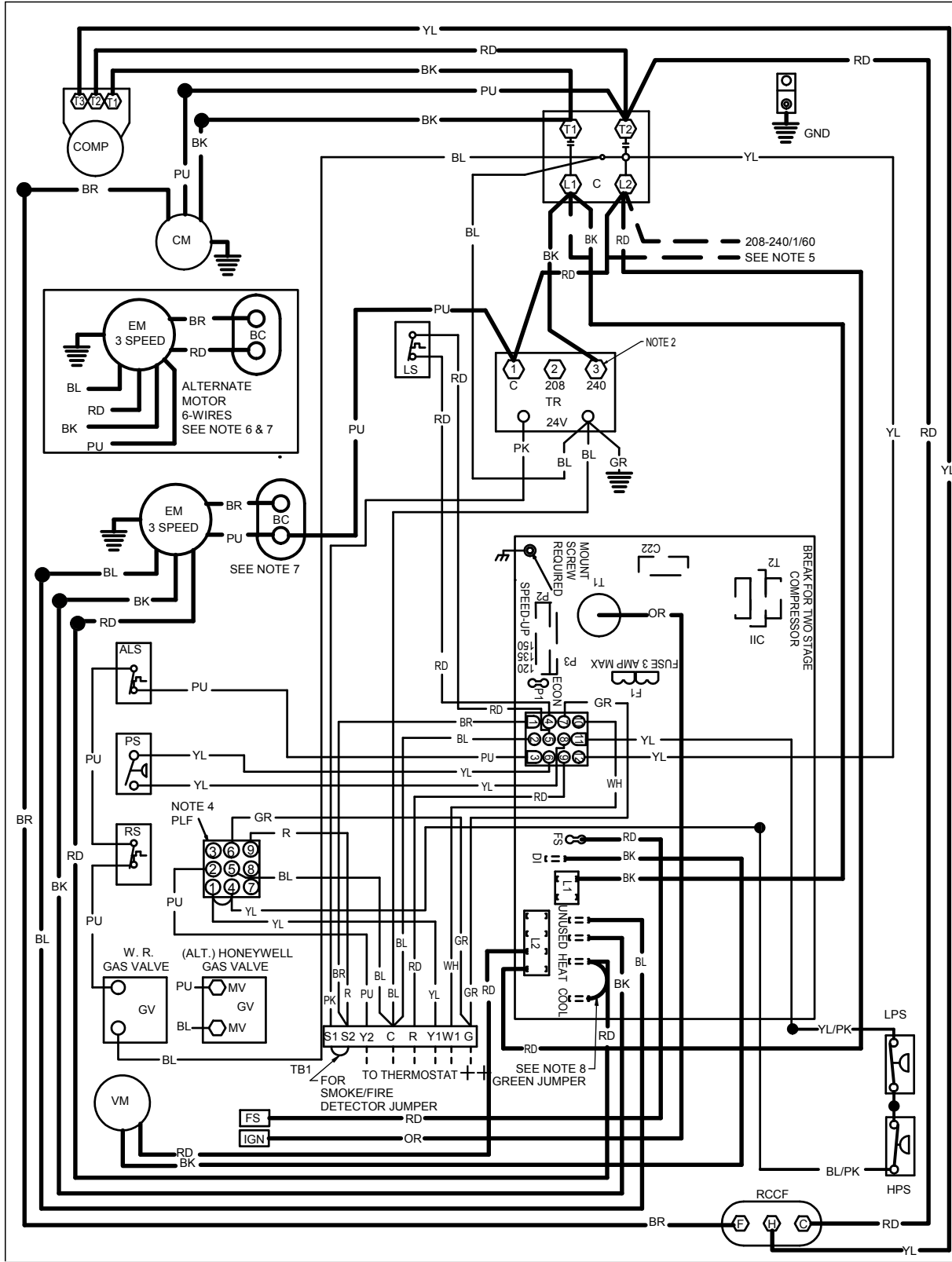

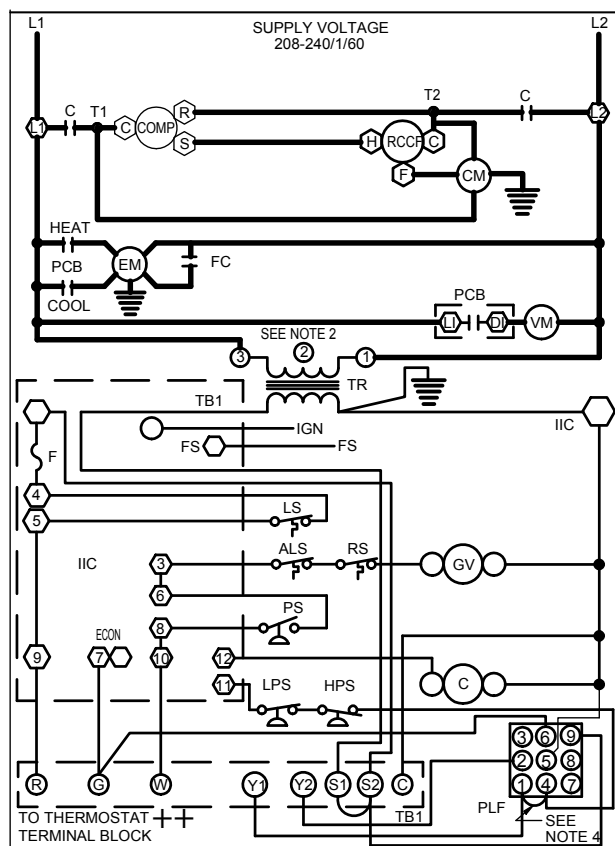

**COMPONENT LEGEND**

- ALS AUXILIARY LIMIT SWITCH
- COMP COMPRESSOR
- CM CONDENSER MOTOR
- C CONTACTOR
- EM EVAPORATOR MOTOR
- F FUSE
- FS FLAME SENSOR
- GND EQUIPMENT GROUND
- GV GAS VALVE
- HPS HIGH PRESSURE SWITCH
- IIC INTEGRATED IGNITION CONTROL
- IGN IGNITOR
- LS LIMIT SWITCH
- LPS LOW PRESSURE SWITCH
- PLF FEMALE PLUG/CONNECTOR
- PS PRESSURE SWITCH
- RCCF RUN CAPACITOR FOR CONDENSER FAN
- RS ROLLOUT SWITCH
- TB1 TERMINAL BLOCK (24V SIGNAL)
- TR TRANSFORMER
- VM VENT MOTOR
- VMR RELAY
- BC BLOWER CAPACITOR

**NOTES**

1. REPLACEMENT WIRE MUST BE THE SAME SIZE AND TYPE OF INSULATION AS ORIGINAL. (USE COPPER CONDUCTOR ONLY).
2. FOR 208 VOLT TRANSFORMER OPERATION MOVE BLACK WIRE FROM TERMINAL 3 TO TERMINAL 2 ON TRANSFORMER.
3. FOR DIFFERENT THAN FACTORY SPEED TAP. CHANGE COOLING SPEED AT COOL TERMINAL. CHANGE HEATING SPEED AT HEAT TERMINAL ON CONTROL BOARD
- 3 SPEED MOTOR  
RD - LOW SPEED  
BL - MED. SPEED  
BK - HIGH SPEED
4. ACCESSORY ECONOMIZER PLUG ADJACENT TO BLOWER HOUSING IN RETURN AIR COMPARTMENT. REMOVE MALE PLUG AND ATTACH FEMALE PLUG TO ECONOMIZER ACCESSORY.
5. USE COPPER CONDUCTORS ONLY.  
++ USE NEC CLASS 2 WIRE.
6. PURPLE WIRE CONNECTS TO TRANSFORMER (PIN 1).
7. SPEED TAP TERMINATIONS SHOWN ON DIAGRAM ARE REPRESENTATIVE, BUT ACTUAL FACTORY SETTING MAY BE DIFFERENT BASED ON HEATING VALUE AND CAPACITY OF UNIT.
8. TO RUN DIFFERENT SPEED FOR HEATING AND COOLING, DISCONNECT GREEN JUMPER FROM "COOL" TERMINAL AND REPLACE WITH APPROPRIATE SPEED TAP. THEN PLACE DISCONNECTED END OF JUMPER ON "UNUSED" TERMINAL LEFT OPEN BY MOVING THE SPEED TAP. SEE UNIT RATING PLATE FOR TYPE AND SIZE OF OVERCURRENT PROTECTION.

- JUNCTION TERMINAL
- INTERNAL TO INTEGRATED CONTROL
- PLUG CONNECTION
- SWITCH (PRESS.)
- OVERCURRENT PROT. DEVICE
- EQUIPMENT GROUND
- FIELD GROUND
- FIELD SPlice
- SWITCH (TEMP)
- IGNITER

**FACTORY WIRING**

- LINE VOLTAGE
- LOW VOLTAGE
- OPTIONAL
- HIGH VOLTAGE
- OPTIONAL
- LOW VOLTAGE
- FIELD WIRING
- HIGH VOLTAGE
- LOW VOLTAGE

**WIRE CODE**

- BK BLACK
- BL BLUE
- BR BROWN
- GR GREEN
- OR ORANGE
- PK PINK
- PU PURPLE
- RD RED
- WH WHITE
- YL YELLOW
- BL/PK BLUE WITH PINK STRIP
- YL/PK YELLOW WITH PINK STRIP

**THERMOSTAT ++ FIELD WIRING**

**NO ECONOMIZER**

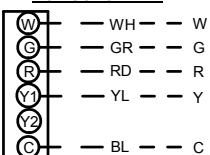

**WITH ECONOMIZER OPTION**

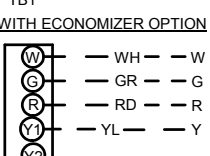

**2 STAGE COOLING**

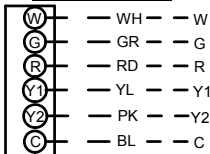

**INSTALLER/SERVICEMAN**

THE STATUS LIGHT ON THE FURNACE CONTROL MAY BE USED AS A GUIDE TO TROUBLESHOOTING THIS APPLIANCE. STATUS LIGHT CODES ARE AS FOLLOWS:

STATUS LIGHT	EQUIP. STATUS	CHECK
ON	NORMAL OPERATION	-
OFF	NO POWER OR INTERNAL CONTROL FAULT	CHECK INPUT POWER CHECK FUSE ON CONTROL REPLACE CONTROL
1 BLINK	IGNITION FAILURE OR OPEN ROLLOUT SWITCH OR OPEN AUX. LIMIT SWITCH	GAS FLOW GAS PRESSURE GAS VALVE FLAME SENSOR FLAME ROLLOUT BAD SWITCH AUX. LIMIT OPEN
2 BLINKS	PRESSURE SWITCH OPEN	CHECK PRESSURE SWITCH
3 BLINKS	PRESSURE SWITCH CLOSED WITHOUT INDUCER ON	CHECK PRESSURE SWITCH
4 BLINKS	OPEN LIMIT SWITCH	MAIN LIMIT OPEN BAD SWITCH
5 BLINKS	FALSE FLAME SENSED	STICKING GAS VALVE
6 BLINKS	COMPRESSOR OUTPUT DELAY	3 MIN. COMP. ANTI-CYCLE TIMER

**High Voltage:** Disconnect all power before servicing or installing this unit. Multiple power sources may be present. Failure to do so may cause property damage, personal injury, or death.

**WARNING**

0140L02912-B

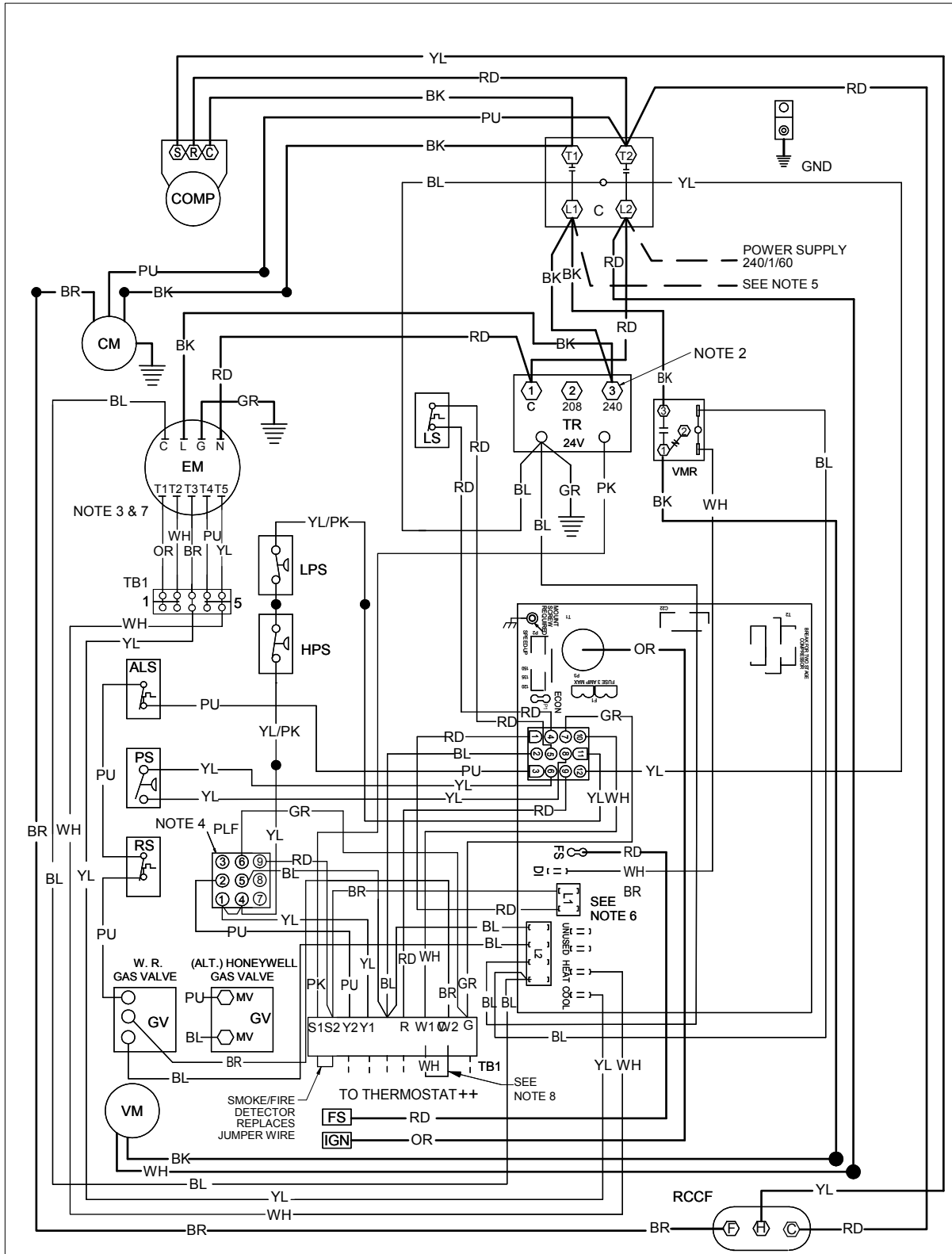

**High Voltage:** Disconnect all power before servicing or installing this unit. Multiple power sources may be present. Failure to do so may cause property damage, personal injury, or death.

**WARNING**

Wiring is subject to change. Always refer to the wiring diagram on the unit for the most up-to-date wiring.

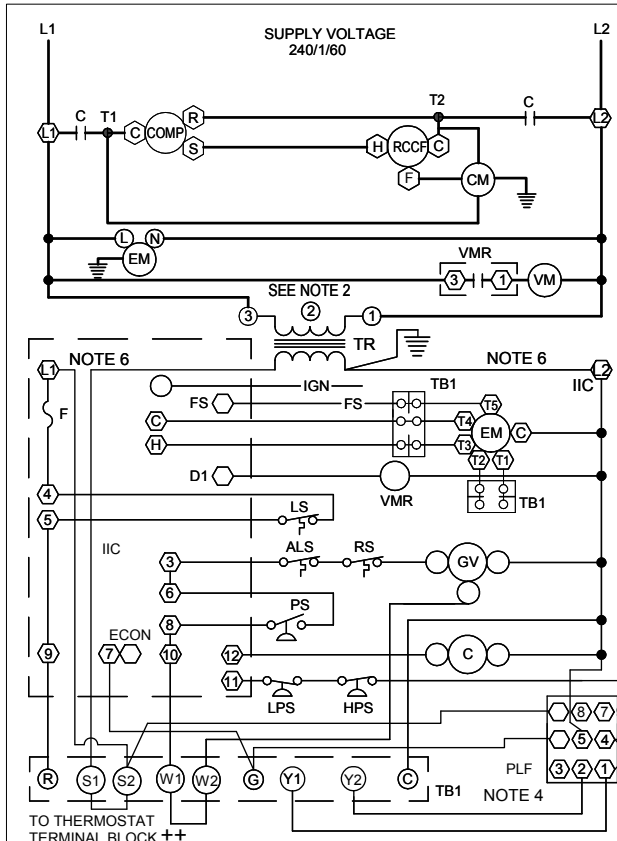

**INSTALLER/SERVICEMAN**

THE STATUS LIGHT ON THE FURNACE CONTROL MAY BE USED AS A GUIDE TO TROUBLESHOOTING THIS APPLIANCE. STATUS LIGHT CODES ARE AS FOLLOWS:

STATUS LIGHT	EQUIP. STATUS	CHECK
ON	NORMAL OPERATION	-
OFF	NO POWER OR INTERNAL CONTROL FAULT	CHECK INPUT POWER CHECK FUSE ON CONTROL REPLACE CONTROL
1 BLINK	IGNITION FAILURE OR OPEN ROLLOUT SWITCH OR OPEN AUX. LIMIT SWITCH	GAS FLOW GAS PRESSURE GAS VALVE FLAME SENSOR FLAME ROLLOUT BAD SWITCH AUX. LIMIT OPEN
2 BLINKS	PRESSURE SWITCH OPEN	CHECK PRESSURE SWITCH
3 BLINKS	PRESSURE SWITCH CLOSED WITHOUT INDUCER ON	CHECK PRESSURE SWITCH
4 BLINKS	OPEN LIMIT SWITCH	MAIN LIMIT OPEN BAD SWITCH
5 BLINKS	FALSE FLAME SENSED	STICKING GAS VALVE
6 BLINKS	COMPRESSOR OUTPUT DELAY	3 MIN. COMP. ANTI-CYCLE TIMER

**COMPONENT LEGEND**

- ALS AUXILIARY LIMIT SWITCH
- COMP COMPRESSOR
- CM CONDENSER MOTOR
- C CONTACTOR
- EM EVAPORATOR MOTOR
- F FUSE
- FS FLAME SENSOR
- GND EQUIPMENT GROUND
- GV GAS VALVE
- HPS HIGH PRESSURE SWITCH
- IIC INTEGRATED IGNITION CONTROL
- IGN IGNITOR
- LPS LOW PRESSURE SWITCH
- LS LIMIT SWITCH
- PLF FEMALE PLUG/CONNECTOR
- PS PRESSURE SWITCH
- RCCCF RUN CAPACITOR FOR COMPRESSOR/FAN
- RS ROLLOUT SWITCH
- TB1 TERMINAL BLOCK (24V SIGNAL)
- TR TRANSFORMER
- VM VENT MOTOR
- VMR VENT MOTOR RELAY

**NOTES**

1. REPLACEMENT WIRE MUST BE THE SAME SIZE AND TYPE OF INSULATION AS ORIGINAL. (USE COPPER CONDUCTOR ONLY).
  2. FOR 208 VOLT TRANSFORMER OPERATION MOVE BLACK WIRE FROM TERMINAL 3 TO TERMINAL 2 ON TRANSFORMER.
  3. FOR DIFFERENT THAN FACTORY SPEED TAP. CHANGE COOLING SPEED AT MOTOR T4 AND T5 TERMINALS. CHANGE HEATING SPEED AT MOTOR T1, T2, AND T3 TERMINALS  
COOLING SPEED (YELLOW WIRE)  
T3 - LOW SPEED  
T4 - HIGH SPEED  
HEATING SPEED (WHITE WIRE)  
T1 - LOW SPEED (070)  
T2 - MED. SPEED  
T5 - HIGH SPEED (140)
  4. ACCESSORY ECONOMIZER PLUG ADJACENT TO BLOWER HOUSING IN RETURN AIR COMPARTMENT. REMOVE MALE PLUG AND ATTACH FEMALE PLUG TO ECONOMIZER ACCESSORY.
  5. USE COPPER CONDUCTORS ONLY.  
++ USE NEC CLASS 2 WIRE.
  6. L1 AND L2 ON ICC CONTROL IS 24V INPUT.
  7. SPEED TAP TERMINATIONS SHOWN ON DIAGRAM ARE REPRESENTATIVE, BUT ACTUAL FACTORY SETTINGS MAY BE DIFFERENT BASED ON THE HEATING VALUE OF THE UNIT.
  8. FOR LOW STAGE OPERATION ONLY. REMOVE WHITE JUMPER. FOR 2 STAGE OPERATION, REMOVE JUMPER AND CONNECT W2 TO W2 ON THERMOSTAT.
- SEE UNIT RATING PLATE FOR TYPE AND SIZE OF OVER CURRENT PROTECTION .

- JUNCTION TERMINAL
- INTERNAL TO INTEGRATED CONTROL
- PLUG CONNECTION
- SWITCH (PRESS.)
- OVERCURRENT PROT. DEVICE
- EQUIPMENT GROUND
- FIELD GROUND
- FIELD SPLICE
- SWITCH (TEMP)
- IGNITER

**FACTORY WIRING**

- LINE VOLTAGE
- LOW VOLTAGE
- OPTIONAL HIGH VOLTAGE
- OPTIONAL LOW VOLTAGE

**FIELD WIRING**

- HIGH VOLTAGE
- LOW VOLTAGE

**WIRE CODE**

- BK BLACK
- BL BLUE
- BR BROWN
- GR GREEN
- OR ORANGE
- PK PINK
- PU PURPLE
- RD RED
- WH WHITE
- YL YELLOW
- BL/PK BLUE WITH PINK STRIP
- YL/PK YELLOW WITH PINK STRIP

**THERMOSTAT FIELD WIRING ++**

**NO ECONOMIZER**

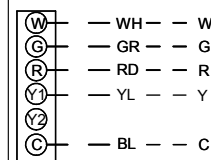

**WITH ECONOMIZER OPTION**

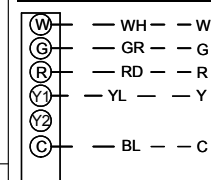

**2 STAGE COOLING**

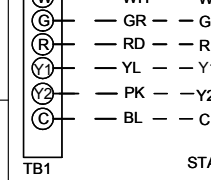

**High Voltage:** Disconnect all power before servicing or installing this unit. Multiple power sources may be present. Failure to do so may cause property damage, personal injury, or death.

**WARNING**

240/1/60 0140L02912-B

Wiring is subject to change. Always refer to the wiring diagram on the unit for the most up-to-date wiring.

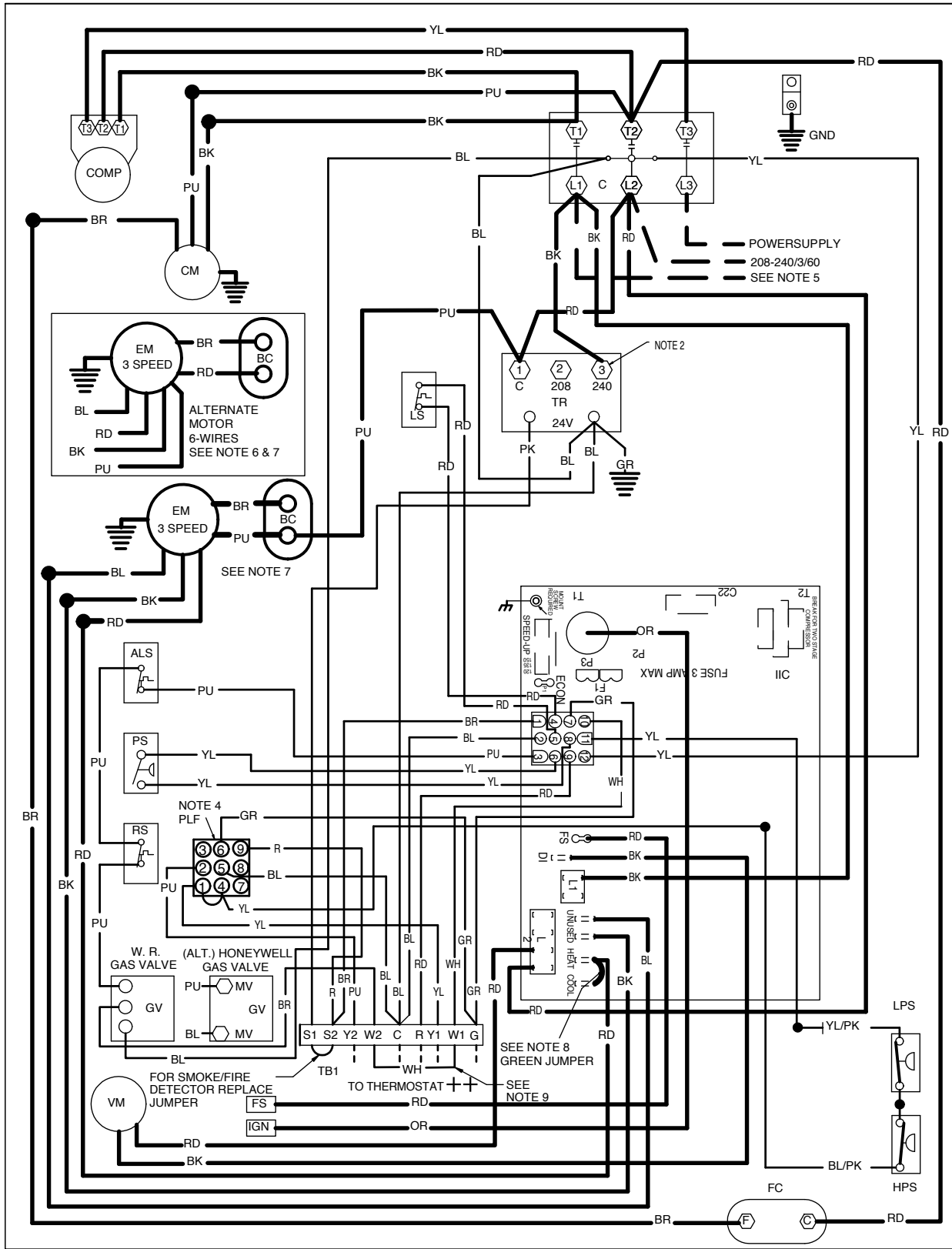

0140L05404-A

**High Voltage:** Disconnect all power before servicing or installing this unit. Multiple power sources may be present. Failure to do so may cause property damage, personal injury, or death.

**WARNING**

Wiring is subject to change. Always refer to the wiring diagram on the unit for the most up-to-date wiring.

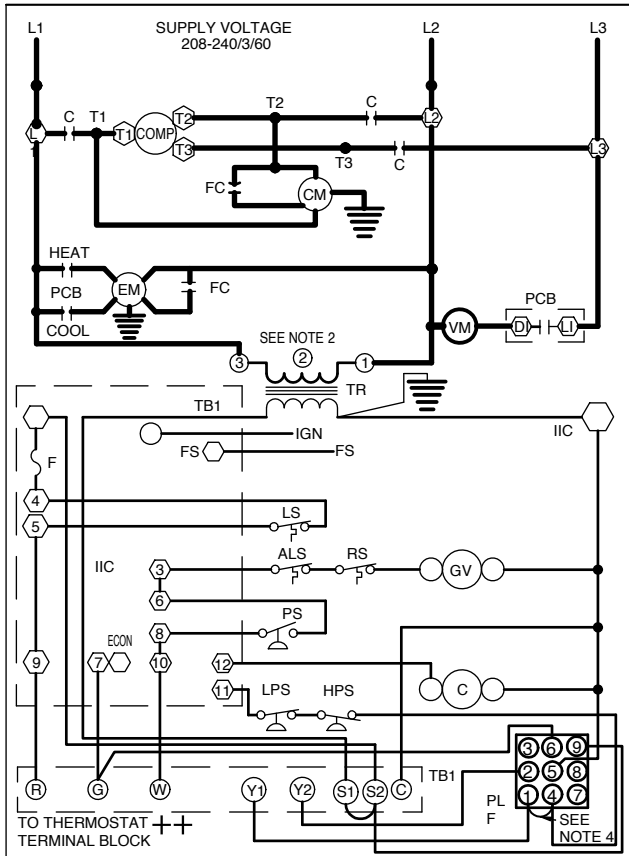

- COMPONENT LEGEND**
- ALS - AUXILIARY LIMIT SWITCH
  - COMP - COMPRESSOR
  - CM - CONDENSER MOTOR
  - C - CONTACTOR
  - EM - EVAPORATOR MOTOR
  - F - FUSE
  - FC - FAN CAPACITOR
  - FS - FLAME SENSOR
  - GND - EQUIPMENT GROUND
  - GV - GAS VALVE
  - HPS - HIGH PRESSURE SWITCH
  - IIC - INTEGRATED IGNITION CONTROL
  - IGN - IGNITOR
  - LS - LIMIT SWITCH
  - LPS - LOW PRESSURE SWITCH
  - PLF - FEMALE PLUG/CONNECTOR
  - PS - PRESSURE SWITCH
  - RS - ROLLOUT SWITCH
  - TB1 - TERMINAL BLOCK (24V SIGNAL)
  - TR - TRANSFORMER
  - VM - VENT MOTOR
  - VMR - VENT MOTOR RELAY
  - BC - BLOWER CAPACITOR

- NOTES**
1. REPLACEMENT WIRE MUST BE THE SAME SIZE AND TYPE OF INSULATION AS ORIGINAL. (USE COPPER CONDUCTOR ONLY).
  2. FOR 208 VOLT TRANSFORMER OPERATION MOVE BLACK WIRE FROM TERMINAL 3 TO TERMINAL 2 ON TRANSFORMER.
  3. FOR DIFFERENT THAN FACTORY SPEED TAP. CHANGE COOLING SPEED AT COOL TERMINAL. CHANGE HEATING SPEED AT HEAT TERMINAL ON CONTROL BOARD.
  4. ACCESSORY ECONOMIZER PLUG ADJACENT TO BLOWER HOUSING IN RETURN AIR COMPARTMENT. REMOVE MALE PLUG AND ATTACH FEMALE PLUG TO ECONOMIZER ACCESSORY.
  5. USE COPPER CONDUCTORS ONLY.
  6. PURPLE WIRE CONNECTS TO TRANSFORMER (PIN 1).
  7. SPEED TAP TERMINATIONS SHOWN ON DIAGRAM ARE REPRESENTATIVE, BUT ACTUAL FACTORY SETTING MAY BE DIFFERENT BASED ON HEATING VALUE AND CAPACITY OF UNIT.
  8. TO RUN DIFFERENT SPEED FOR HEATING AND COOLING. DISCONNECT GREEN JUMPER FROM "COOL" TERMINAL AND REPLACE WITH APPROPRIATE SPEED TAP. THEN PLACE DISCONNECTED END OF JUMPER ON "UNUSED" TERMINAL LEFT OPEN BY MOVING THE SPEED TAP.
  9. FOR LOW STAGE OPERATION ONLY, REMOVE WHITE JUMPER. FOR 2 STAGE OPERATION, REMOVE JUMPER AND CONNECT W2 TO W1 ON THERMOSTAT.
- SEE UNIT RATING PLATE FOR TYPE AND SIZE OF OVERCURRENT PROTECTION.

- FACTORY WIRING**
- LINE VOLTAGE
  - LOW VOLTAGE
  - - - OPTIONAL HIGH VOLTAGE
- FIELD WIRING**
- - - HIGH VOLTAGE
  - - - LOW VOLTAGE
- WIRE CODE**
- BK BLACK
  - BL BLUE
  - BR BROWN
  - GR GREEN
  - OR ORANGE
  - PK PINK
  - PU PURPLE
  - RD RED
  - WH WHITE
  - YL YELLOW
  - BL/PK BLUE WITH PINK STRIP
  - YL/PK YELLOW WITH PINK STRIP

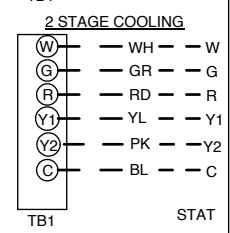
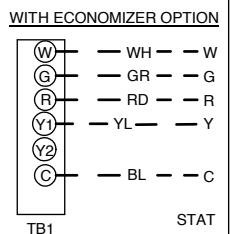
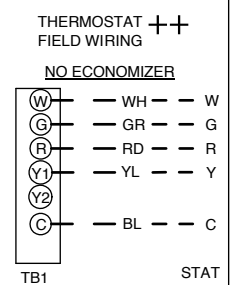

**INSTALLER/SERVICEMAN**

THE STATUS LIGHT ON THE FURNACE CONTROL MAY BE USED AS A GUIDE TO TROUBLESHOOTING THIS APPLIANCE. STATUS LIGHT CODES ARE AS FOLLOWS:

STATUS LIGHT	EQUIP. STATUS	CHECK
ON	NORMAL OPERATION	-
OFF	NO POWER OR INTERNAL CONTROL FAULT	CHECK INPUT POWER CHECK FUSE ON CONTROL REPLACE CONTROL
1 BLINK	IGNITION FAILURE OR OPEN ROLLOUT SWITCH OR OPEN AUX. LIMIT SWITCH	GAS FLOW GAS PRESSURE GAS VALVE FLAME SENSOR FLAME ROLLOUT BAD SWITCH AUX. LIMIT OPEN
2 BLINKS	PRESSURE SWITCH OPEN	CHECK PRESSURE SWITCH
3 BLINKS	PRESSURE SWITCH CLOSED WITHOUT INDUCER ON	CHECK PRESSURE SWITCH
4 BLINKS	OPEN LIMIT SWITCH	MAIN LIMIT OPEN BAD SWITCH
5 BLINKS	FALSE FLAME SENSED	STICKING GAS VALVE
6 BLINKS	COMPRESSOR OUTPUT DELAY	3 MIN. COMP. ANTI-CYCLE TIMER

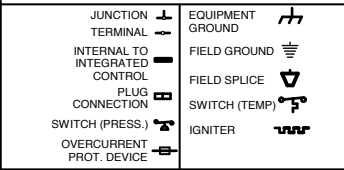

208-240/3/60 0140L05404-A

**High Voltage:** Disconnect all power before servicing or installing this unit. Multiple power sources may be present. Failure to do so may cause property damage, personal injury, or death.

**WARNING**

Wiring is subject to change. Always refer to the wiring diagram on the unit for the most up-to-date wiring.



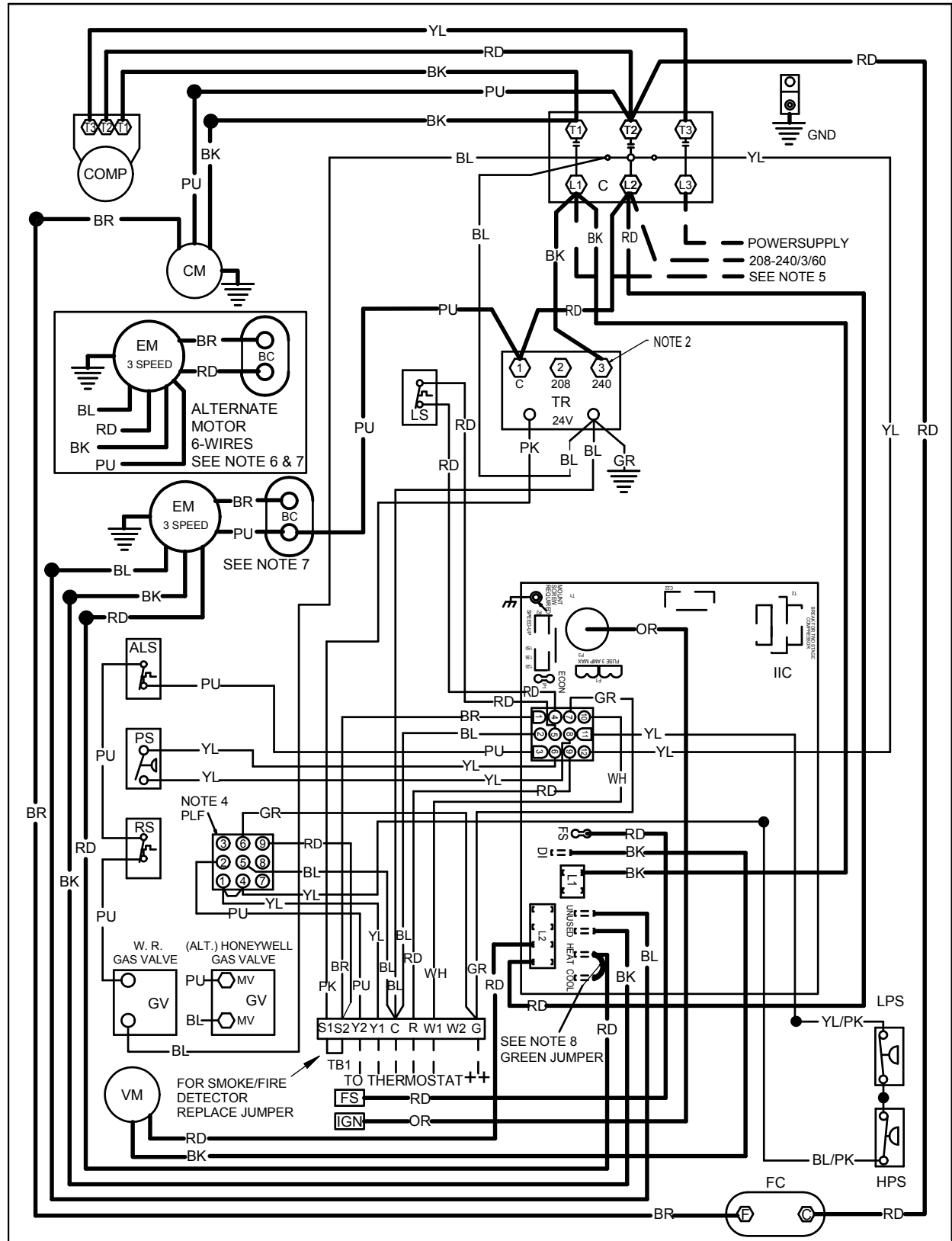

0140L05406-A

**High Voltage:** Disconnect all power before servicing or installing this unit. Multiple power sources may be present. Failure to do so may cause property damage, personal injury, or death.

**WARNING**

Wiring is subject to change. Always refer to the wiring diagram on the unit for the most up-to-date wiring.

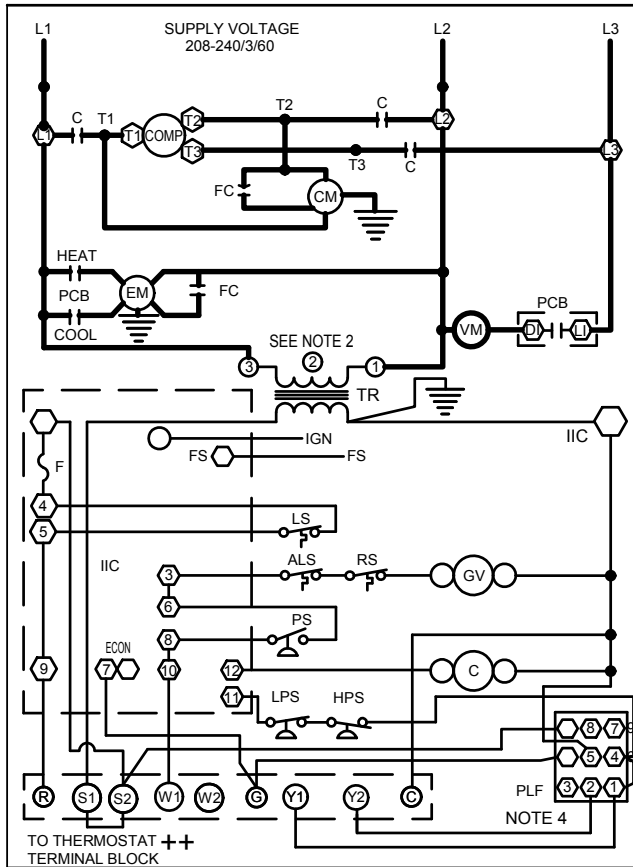

- COMPONENT LEGEND**
- ALS AUXILIARY LIMIT SWITCH
  - COMP COMPRESSOR
  - CM CONDENSER MOTOR
  - C CONTACTOR
  - EM EVAPORATOR MOTOR
  - F FUSE
  - FC FAN CAPACITOR
  - FS FLAME SENSOR
  - GND EQUIPMENT GROUND
  - GV GAS VALVE
  - HPS HIGH PRESSURE SWITCH
  - IIC INTEGRATED IGNITION CONTROL
  - IGN IGNITOR
  - LS LIMIT SWITCH
  - LPS LOW PRESSURE SWITCH
  - PLF FEMALE PLUG/CONNECTOR
  - PS PRESSURE SWITCH
  - RS ROLLOUT SWITCH
  - TB1 TERMINAL BLOCK (24V SIGNAL)
  - TR TRANSFORMER
  - VM VENT MOTOR
  - VMR VENT MOTOR RELAY
  - BC BLOWER CAPACITOR

- NOTES**
1. REPLACEMENT WIRE MUST BE THE SAME SIZE AND TYPE OF INSULATION AS ORIGINAL. (USE COPPER CONDUCTOR ONLY).
  2. FOR 208 VOLT TRANSFORMER OPERATION MOVE BLACK WIRE FROM TERMINAL 3 TO TERMINAL 2 ON TRANSFORMER.
  3. FOR DIFFERENT THAN FACTORY SPEED TAP. CHANGE COOLING SPEED AT COOL TERMINAL. CHANGE HEATING SPEED AT HEAT TERMINAL ON CONTROL BOARD.
  4. ACCESSORY ECONOMIZER PLUG ADJACENT TO BLOWER HOUSING IN RETURN AIR COMPARTMENT. REMOVE MALE PLUG AND ATTACH FEMALE PLUG TO ECONOMIZER ACCESSORY.
  5. USE COPPER CONDUCTORS ONLY. ++ USE NEC CLASS 2 WIRE.
  6. PURPLE WIRE CONNECTS TO TRANSFORMER (PIN 1).
  7. SPEED TAP TERMINATIONS SHOWN ON DIAGRAM ARE REPRESENTATIVE. BUT ACTUAL FACTORY SETTING MAY BE DIFFERENT BASED ON HEATING VALUE AND CAPACITY OF UNIT.
  8. TO RUN DIFFERENT SPEED FOR HEATING AND COOLING. DISCONNECT GREEN JUMPER FROM "COOL" TERMINAL AND REPLACE WITH APPROPRIATE SPEED TAP. THEN PLACE DISCONNECTED END OF JUMPER ON "UNUSED" TERMINAL LEFT OPEN BY MOVING THE SPEED TAP.

SEE UNIT RATING PLATE FOR TYPE AND SIZE OF OVERCURRENT PROTECTION.

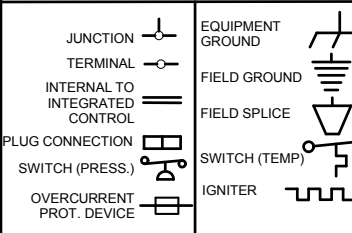

- FACTORY WIRING**
- LINE VOLTAGE
  - LOW VOLTAGE
  - OPTIONAL HIGH VOLTAGE
  - OPTIONAL LOW VOLTAGE
- FIELD WIRING**
- HIGH VOLTAGE
  - LOW VOLTAGE
- WIRE CODE**
- BK BLACK
  - BL BLUE
  - BR BROWN
  - GR GREEN
  - OR ORANGE
  - PK PINK
  - PU PURPLE
  - RD RED
  - WH WHITE
  - YL YELLOW
  - BL/PK BLUE WITH PINK STRIP
  - YL/PK YELLOW WITH PINK STRIP

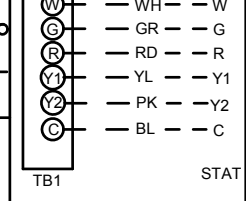
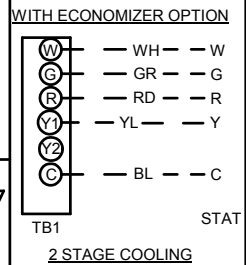
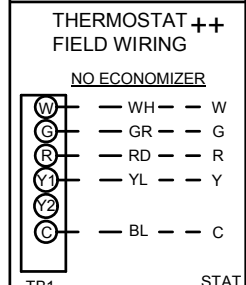

**INSTALLER/SERVICEMAN**  
THE STATUS LIGHT ON THE FURNACE CONTROL MAY BE USED AS A GUIDE TO TROUBLESHOOTING THIS APPLIANCE. STATUS LIGHT CODES ARE AS FOLLOWS:

STATUS LIGHT	EQUIP. STATUS	CHECK
ON	NORMAL OPERATION	-
OFF	NO POWER OR INTERNAL CONTROL FAULT	CHECK INPUT POWER CHECK FUSE ON CONTROL REPLACE CONTROL
1 BLINK	IGNITION FAILURE OR OPEN ROLLOUT SWITCH OR OPEN AUX. LIMIT SWITCH	GAS FLOW GAS PRESSURE GAS VALVE FLAME SENSOR FLAME ROLLOUT BAD SWITCH AUX. LIMIT OPEN
2 BLINKS	PRESSURE SWITCH OPEN	CHECK PRESSURE SWITCH
3 BLINKS	PRESSURE SWITCH CLOSED WITHOUT INDUCER ON	CHECK PRESSURE SWITCH
4 BLINKS	OPEN LIMIT SWITCH	MAIN LIMIT OPEN BAD SWITCH
5 BLINKS	FALSE FLAME SENSED	STICKING GAS VALVE
6 BLINKS	COMPRESSOR OUTPUT DELAY	3 MIN. COMP. ANTI-CYCLE TIMER

208-240/3/60 0140L05406-A

**High Voltage:** Disconnect all power before servicing or installing this unit. Multiple power sources may be present. Failure to do so may cause property damage, personal injury, or death.

**WARNING**

Wiring is subject to change. Always refer to the wiring diagram on the unit for the most up-to-date wiring.

0140L05415-A

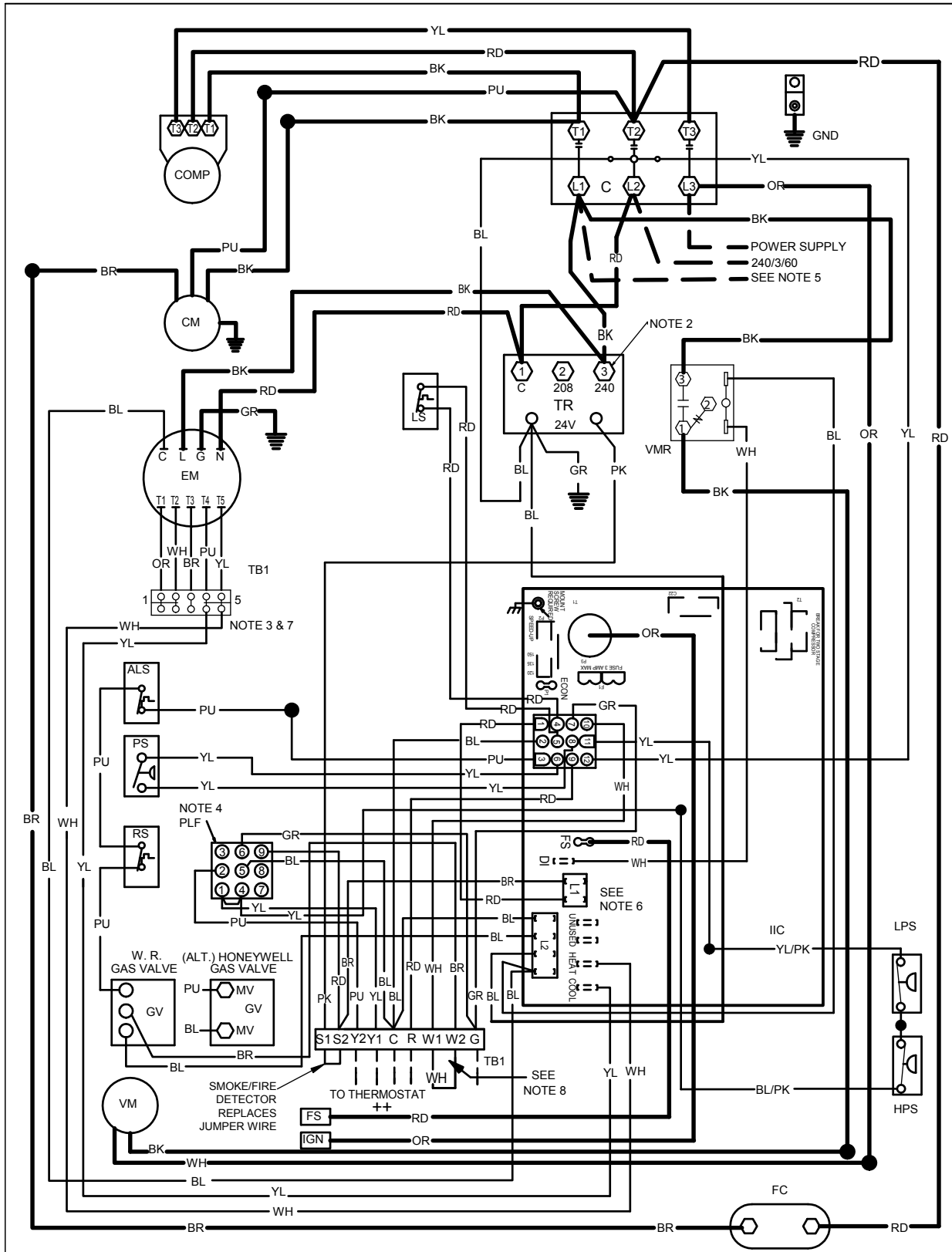

**High Voltage:** Disconnect all power before servicing or installing this unit. Multiple power sources may be present. Failure to do so may cause property damage, personal injury, or death.

**WARNING**

Wiring is subject to change. Always refer to the wiring diagram on the unit for the most up-to-date wiring.

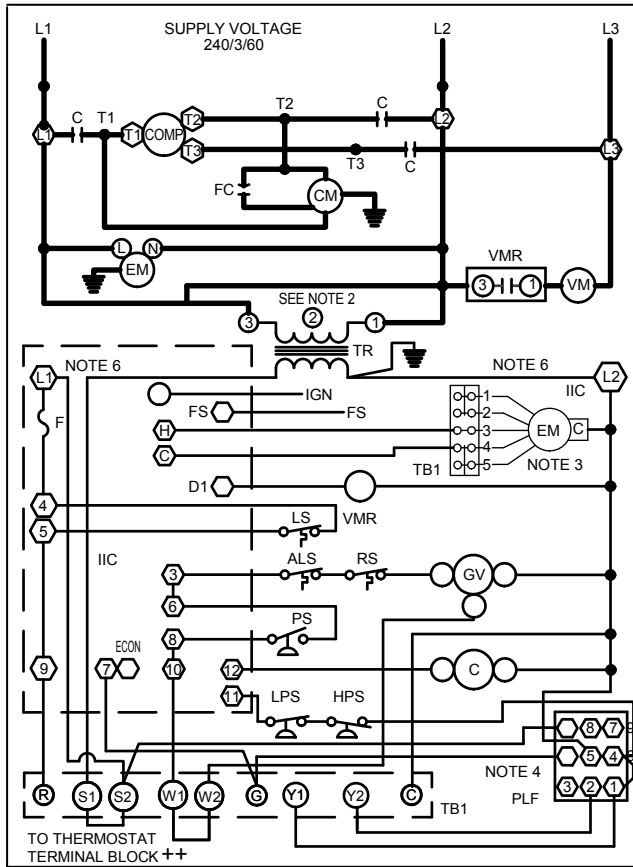

- COMPONENT LEGEND**
- ALS AUXILIARY LIMIT SWITCH
  - COMP COMPRESSOR
  - CM CONDENSER MOTOR
  - C CONTACTOR
  - EM EVAPORATOR MOTOR
  - F FUSE
  - FC FAN CAPACITOR
  - FS FLAME SENSOR
  - GND EQUIPMENT GROUND
  - GV GAS VALVE
  - HPS HIGH PRESSURE SWITCH
  - IIC INTEGRATED IGNITION CONTROL
  - IGN IGNITOR
  - LS LIMIT SWITCH
  - LPS LOW PRESSURE SWITCH
  - PLF FEMALE PLUG/CONNECTOR
  - PS PRESSURE SWITCH
  - RS ROLLOUT SWITCH
  - TB1 TERMINAL BLOCK (24V SIGNAL)
  - TR TRANSFORMER
  - VM VENT MOTOR
  - VMR VENT MOTOR RELAY

- NOTES**
1. REPLACEMENT WIRE MUST BE THE SAME SIZE AND TYPE OF INSULATION AS ORIGINAL. (USE COPPER CONDUCTOR ONLY).
  2. FOR 208 VOLT TRANSFORMER OPERATION MOVE BLACK WIRES FROM TERMINAL 3 TO TERMINAL 2 ON TRANSFORMER.
  3. FOR DIFFERENT THAN FACTORY SPEED TAP. CHANGE COOLING SPEED AT MOTOR T3 AND T4 TERMINALS. CHANGE HEATING SPEED AT MOTOR T1, T2, AND T5 TERMINALS

- COOLING SPEED (YELLOW WIRE)**
- T3 - LOW SPEED
  - T4 - HIGH SPEED
- HEATING SPEED (WHITE WIRE)**
- T1 - LOW SPEED (070)
  - T2 - MED. SPEED
  - T5 - HIGH SPEED (140)

4. ACCESSORY ECONOMIZER PLUG ADJACENT TO BLOWER HOUSING IN RETURN AIR COMPARTMENT. REMOVE MALE PLUG AND ATTACH FEMALE PLUG TO ECONOMIZER ACCESSORY.
  5. USE COPPER CONDUCTORS ONLY. ++ USE NEC CLASS 2 WIRE.
  6. L1 AND L2 ON ICC CONTROL IS 24V INPUT.
  7. SPEED TAP TERMINATIONS SHOWN ON DIAGRAM ARE REPRESENTATIVE, BUT ACTUAL FACTORY SETTINGS MAY BE DIFFERENT BASED ON THE HEATING VALUE OF THE UNIT.
  8. FOR LOW STAGE OPERATION ONLY, REMOVE WHITE JUMPER. FOR 2 STAGE OPERATION, REMOVE JUMPER AND CONNECT W2 TO W2 ON THERMOSTAT.
- SEE UNIT RATING PLATE FOR TYPE AND SIZE OF OVER CURRENT PROTECTION

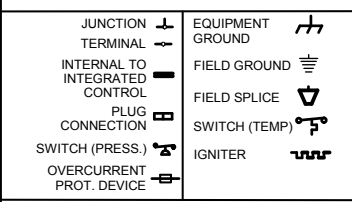

- FACTORY WIRING**
- LINE VOLTAGE
  - LOW VOLTAGE
  - OPTIONAL HIGH VOLTAGE
  - OPTIONAL LOW VOLTAGE
- FIELD WIRING**
- HIGH VOLTAGE
  - LOW VOLTAGE
- WIRE CODE**
- BK BLACK
  - BL BLUE
  - BR BROWN
  - GR GREEN
  - OR ORANGE
  - PK PINK
  - PU PURPLE
  - RD RED
  - WH WHITE
  - YL YELLOW
  - BL/PK BLUE WITH PINK STRIP
  - YL/PK YELLOW WITH PINK STRIP

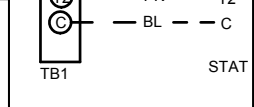
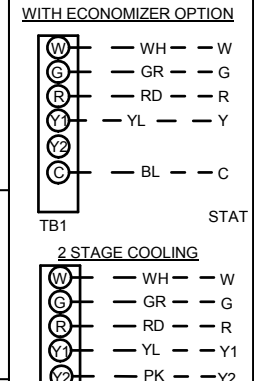
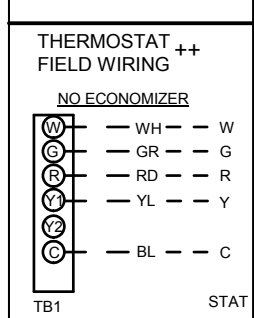

**INSTALLER/SERVICEMAN**

THE STATUS LIGHT ON THE FURNACE CONTROL MAY BE USED AS A GUIDE TO TROUBLESHOOTING THIS APPLIANCE. STATUS LIGHT CODES ARE AS FOLLOWS:

STATUS LIGHT	EQUIP. STATUS	CHECK
ON	NORMAL OPERATION	-
OFF	NO POWER OR INTERNAL CONTROL FAULT	CHECK INPUT POWER CHECK FUSE ON CONTROL REPLACE CONTROL
1 BLINK	IGNITION FAILURE OR OPEN ROLLOUT SWITCH OR OPEN AUX. LIMIT SWITCH	GAS FLOW GAS PRESSURE GAS VALVE FLAME SENSOR FLAME ROLLOUT BAD SWITCH AUX. LIMIT OPEN
2 BLINKS	PRESSURE SWITCH OPEN	CHECK PRESSURE SWITCH
3 BLINKS	PRESSURE SWITCH CLOSED WITHOUT INDUCER ON	CHECK PRESSURE SWITCH
4 BLINKS	OPEN LIMIT SWITCH	MAIN LIMIT OPEN BAD SWITCH
5 BLINKS	FALSE FLAME SENSED	STICKING GAS VALVE
6 BLINKS	COMPRESSOR OUTPUT DELAY	3 MIN. COMP. ANTI-CYCLE TIMER

**High Voltage:** Disconnect all power before servicing or installing this unit. Multiple power sources may be present. Failure to do so may cause property damage, personal injury, or death.

**WARNING**

Wiring is subject to change. Always refer to the wiring diagram on the unit for the most up-to-date wiring.

230/3/60 0140L05415-A

0140L05405-A

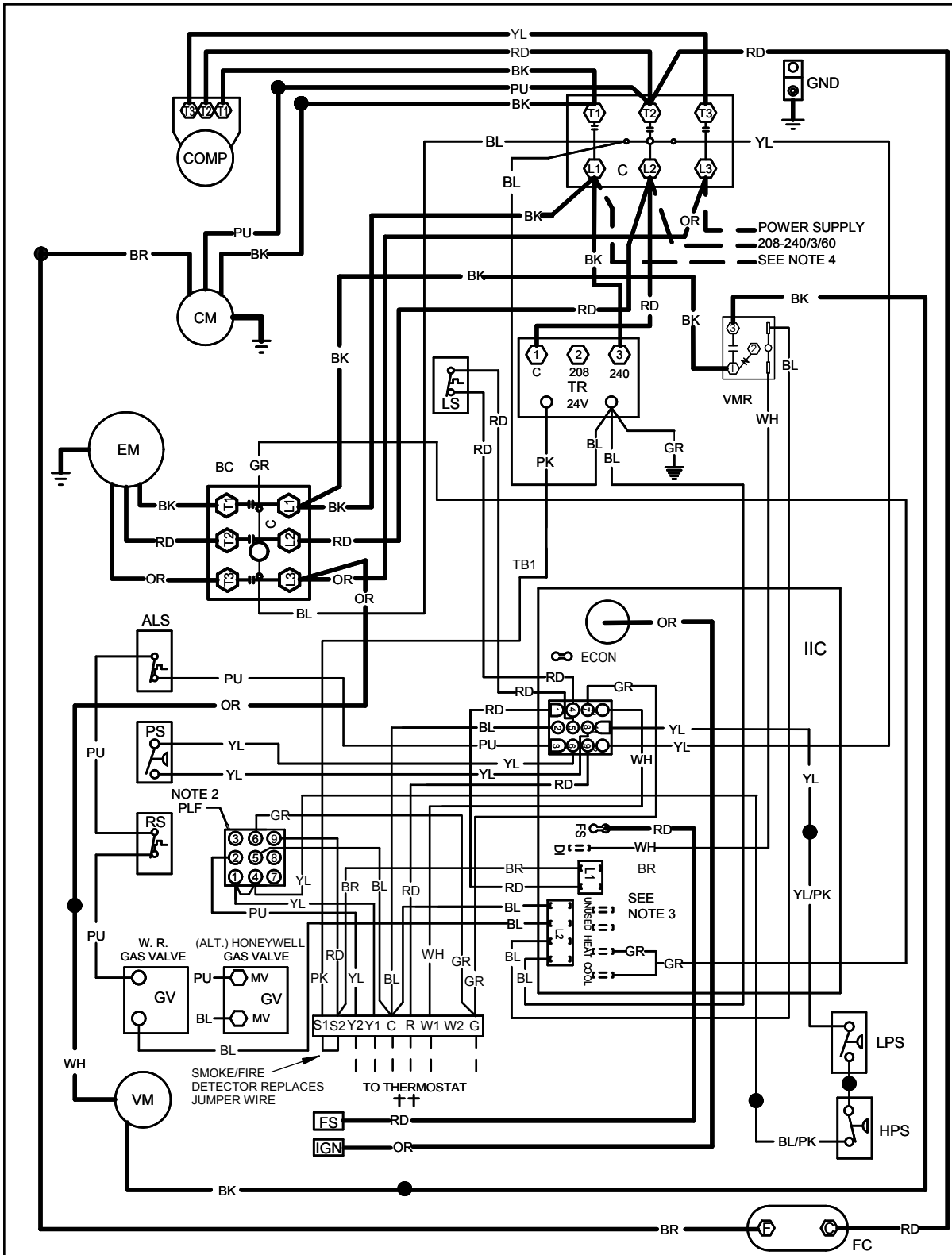

**High Voltage:** Disconnect all power before servicing or installing this unit. Multiple power sources may be present. Failure to do so may cause property damage, personal injury, or death.

**WARNING**

Wiring is subject to change. Always refer to the wiring diagram on the unit for the most up-to-date wiring.

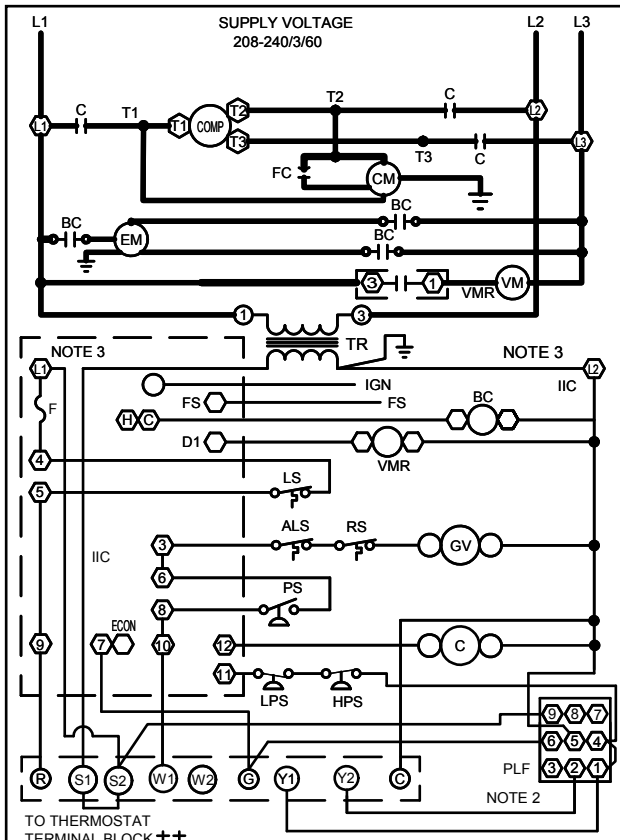

- COMPONENT LEGEND**
- ALS AUXILIARY LIMIT SWITCH
  - BC BLOWER CONTACTOR
  - COMP COMPRESSOR
  - CM CONDENSER MOTOR
  - C CONTACTOR
  - EM EVAPORATOR MOTOR
  - F FUSE
  - FC FAN CAPACITOR
  - FS FLAME SENSOR
  - GND EQUIPMENT GROUND
  - GV GAS VALVE
  - HPS HIGH PRESSURE SWITCH
  - IBR INDOOR BLOWER RELAY
  - IIC INTEGRATED IGNITION CONTROL
  - IGN IGNITOR
  - LPS LOW PRESSURE SWITCH
  - LS LIMIT SWITCH
  - PLF FEMALE PLUG/CONNECTOR
  - PS PRESSURE SWITCH
  - RS ROLLOUT SWITCH
  - TB1 TERMINAL BLOCK (24V SIGNAL)
  - TR TRANSFORMER
  - VM VENT MOTOR
  - VMR VENT MOTOR RELAY

- FACTORY WIRING**
- LINE VOLTAGE
  - LOW VOLTAGE
  - OPTIONAL HIGH VOLTAGE
- FIELD WIRING**
- HIGH VOLTAGE
  - LOW VOLTAGE
- WIRE CODE**
- BK BLACK
  - BL BLUE
  - BR BROWN
  - GR GREEN
  - OR ORANGE
  - PK PINK
  - PU PURPLE
  - RD RED
  - WH WHITE
  - YL YELLOW
  - BL/PK BLUE WITH PINK STRIP
  - YL/PK YELLOW WITH PINK STRIP

- NOTES**
1. REPLACEMENT WIRE MUST BE THE SAME SIZE AND TYPE OF INSULATION AS ORIGINAL (USE COPPER CONDUCTOR ONLY).
  2. ACCESSORY ECONOMIZER PLUG ADJACENT TO BLOWER HOUSING IN RETURN AIR COMPARTMENT. REMOVE MALE PLUG AND ATTACH FEMALE PLUG TO THE ECONOMIZER ACCESSORY.
  3. L1 AND L2 ON IIC CONTROL IS 24V INPUT.
  4. USE COPPER CONDUCTORS ONLY.
  5. FOR 208 VOLT TRANSFORMER OPERATION, MOVE BLACK WIRE FROM TERMINAL 3 TO TERMINAL 2 ON TRANSFORMER.

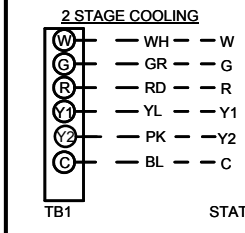
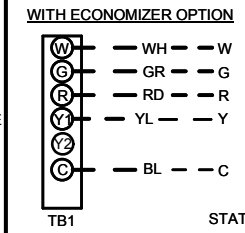
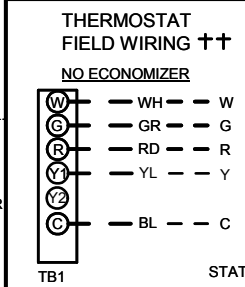

**INSTALLER/SERVICEMAN**

THE STATUS LIGHT ON THE FURNACE CONTROL MAY BE USED AS A GUIDE TO TROUBLESHOOTING THIS APPLIANCE. STATUS LIGHT CODES ARE AS FOLLOWS:

STATUS LIGHT	EQUIP. STATUS	CHECK
ON	NORMAL OPERATION	-
OFF	NO POWER OR INTERNAL CONTROL	CHECK INPUT POWER CHECK FUSE ON CONTROL REPLACE CONTROL
1 BLINK	IGNITION FAILURE OPEN ROLLOUT SWITCH OPEN AUX. LIMIT SWITCH	GAS FLOW GAS PRESSURE GAS VALVE FLAME SENSOR FLAME ROLLOUT BAD SWITCH AUX. LIMIT OPEN
2 BLINKS	PRESSURE SWITCH OPEN	CHECK PRESSURE SWITCH
3 BLINKS	PRESSURE SWITCH CLOSED WITHOUT INDUCER ON	CHECK PRESSURE SWITCH
4 BLINKS	OPEN LIMIT SWITCH	MAIN LIMIT OPEN BAD SWITCH
5 BLINKS	FALSE FLAME SENSED	STICKING GAS VALVE
6 BLINKS	COMPRESSOR OUTPUT DELAY	3 MIN. COMP. ANTI-CYCLE TIMER

SEE UNIT RATING PLATE FOR TYPE AND SIZE OF OVER CURRENT PROTECTION



208-240/3/60 0140L05405-A

**High Voltage:** Disconnect all power before servicing or installing this unit. Multiple power sources may be present. Failure to do so may cause property damage, personal injury, or death.

**WARNING**

Wiring is subject to change. Always refer to the wiring diagram on the unit for the most up-to-date wiring.

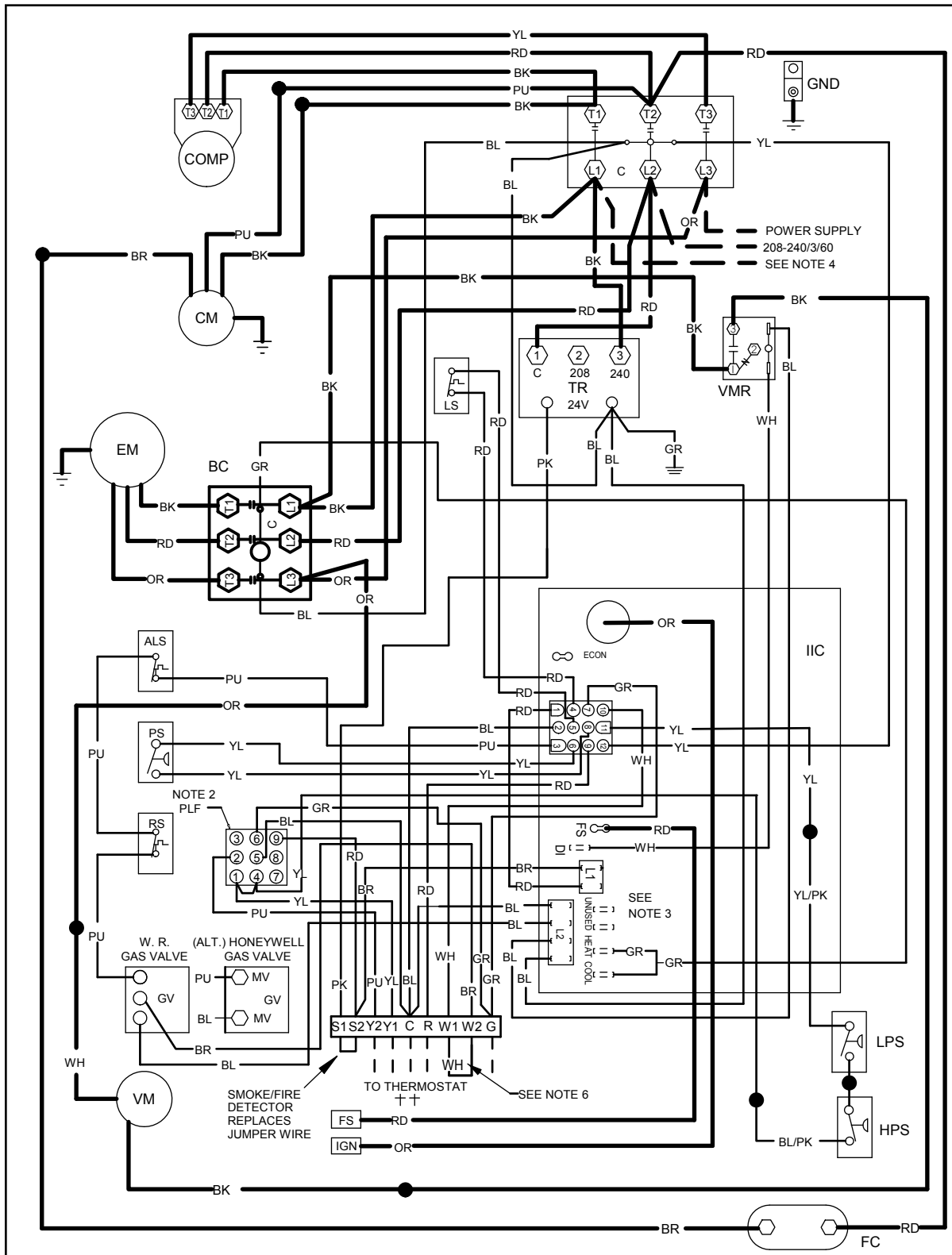

0140L05401-A

**High Voltage:** Disconnect all power before servicing or installing this unit. Multiple power sources may be present. Failure to do so may cause property damage, personal injury, or death.

**WARNING**

Wiring is subject to change. Always refer to the wiring diagram on the unit for the most up-to-date wiring.

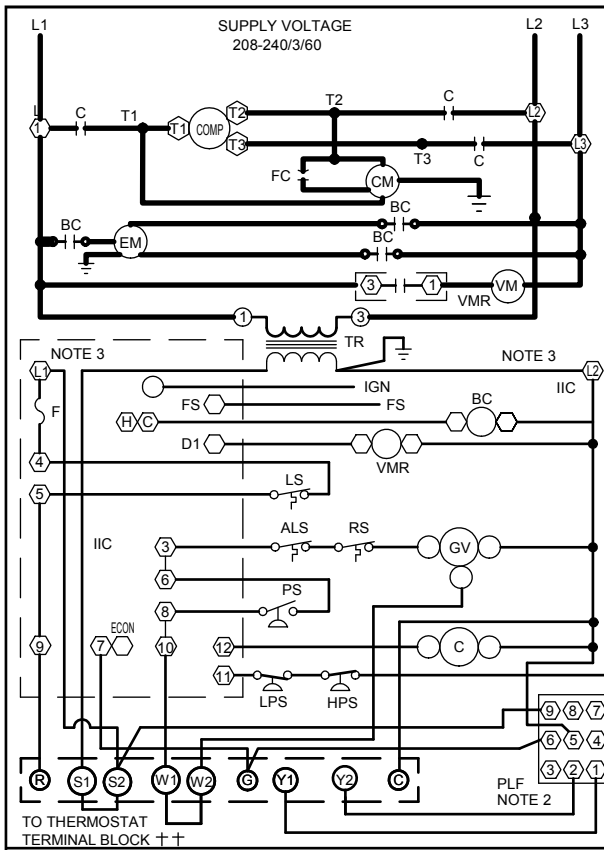

- COMPONENT LEGEND**
- ALS AUXILIARY LIMIT SWITCH
  - BC BLOWER CONTACTOR
  - COMP COMPRESSOR
  - CM CONDENSER MOTOR
  - C CONTACTOR
  - EM EVAPORATOR MOTOR
  - F FUSE
  - FC FAN CAPACITOR
  - FS FLAME SENSOR
  - GND EQUIPMENT GROUND
  - GV GAS VALVE
  - HPS HIGH PRESSURE SWITCH
  - IBR INDOOR BLOWER RELAY
  - IIC INTEGRATED IGNITION CONTROL
  - IGN IGNITOR
  - LPS LOW PRESSURE SWITCH
  - LS LIMIT SWITCH
  - PLF FEMALE PLUG/CONNECTOR
  - PS PRESSURE SWITCH
  - RS ROLLOUT SWITCH
  - TB1 TERMINAL BLOCK (24V SIGNAL)
  - TR TRANSFORMER
  - VM VENT MOTOR
  - VMR VENT MOTOR RELAY

- NOTES**
1. REPLACEMENT WIRE MUST BE THE SAME SIZE AND TYPE OF INSULATION AS ORIGINAL. (USE COPPER CONDUCTOR ONLY).
  2. ACCESSORY ECONOMIZER PLUG ADJACENT TO BLOWER HOUSING IN RETURN AIR COMPARTMENT. REMOVE MALE PLUG AND ATTACH FEMALE PLUG TO THE ECONOMIZER ACCESSORY.
  3. L1 AND L2 ON IIC CONTROL IS 24V INPUT.
  4. USE COPPER CONDUCTORS ONLY. ++ USE NEC CLASS 2 WIRE.
  5. FOR 208 VOLT TRANSFORMER OPERATION, MOVE BLACK WIRE FROM TERMINAL (3) TO TERMINAL (2) ON TRANSFORMER.
  6. FOR LOW STAGE OPERATION ONLY, REMOVE WHITE JUMPER. FOR 2 STAGE OPERATION, REMOVE JUMPER AND CONNECT W2 TO W2 ON THERMOSTAT.

SEE UNIT RATING PLATE FOR TYPE AND SIZE OF OVER CURRENT PROTECTION



208-240/3/60 0140L05401-A

- FACTORY WIRING**
- LINE VOLTAGE
  - LOW VOLTAGE
  - OPTIONAL HIGH VOLTAGE
- FIELD WIRING**
- HIGH VOLTAGE
  - LOW VOLTAGE
- WIRE CODE**
- BK BLACK
  - BL BLUE
  - BR BROWN
  - GR GREEN
  - OR ORANGE
  - PK PINK
  - PU PURPLE
  - RD RED
  - WH WHITE
  - YL YELLOW
  - BL/PK BLUE WITH PINK STRIP
  - YL/PK YELLOW WITH PINK STRIP

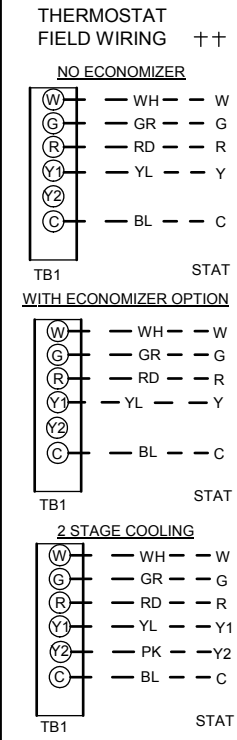

**INSTALLER/SERVICEMAN**

THE STATUS LIGHT ON THE FURNACE CONTROL MAY BE USED AS A GUIDE TO TROUBLESHOOTING THIS APPLIANCE. STATUS LIGHT CODES ARE AS FOLLOWS:

STATUS LIGHT	EQUIP. STATUS	CHECK
ON	NORMAL OPERATION	-
OFF	NO POWER OR INTERNAL CONTROL	CHECK INPUT POWER CHECK FUSE ON CONTROL REPLACE CONTROL
1 BLINK	IGNITION FAILURE	GAS FLOW GAS PRESSURE GAS VALVE
	OPEN ROLLOUT SWITCH	FLAME SENSOR FLAME ROLLOUT BAD SWITCH
2 BLINKS	OPEN AUX. LIMIT SWITCH	AUX. LIMIT OPEN
	PRESSURE SWITCH OPEN	CHECK PRESSURE SWITCH
3 BLINKS	PRESSURE SWITCH CLOSED WITHOUT INDUCER ON	CHECK PRESSURE SWITCH
4 BLINKS	OPEN LIMIT SWITCH	MAIN LIMIT OPEN BAD SWITCH
5 BLINKS	FALSE FLAME SENSED	STICKING GAS VALVE
6 BLINKS	COMPRESSOR OUTPUT DELAY	3 MIN. COMP. ANTI-CYCLE TIMER

**High Voltage:** Disconnect all power before servicing or installing this unit. Multiple power sources may be present. Failure to do so may cause property damage, personal injury, or death.

**WARNING**

Wiring is subject to change. Always refer to the wiring diagram on the unit for the most up-to-date wiring.



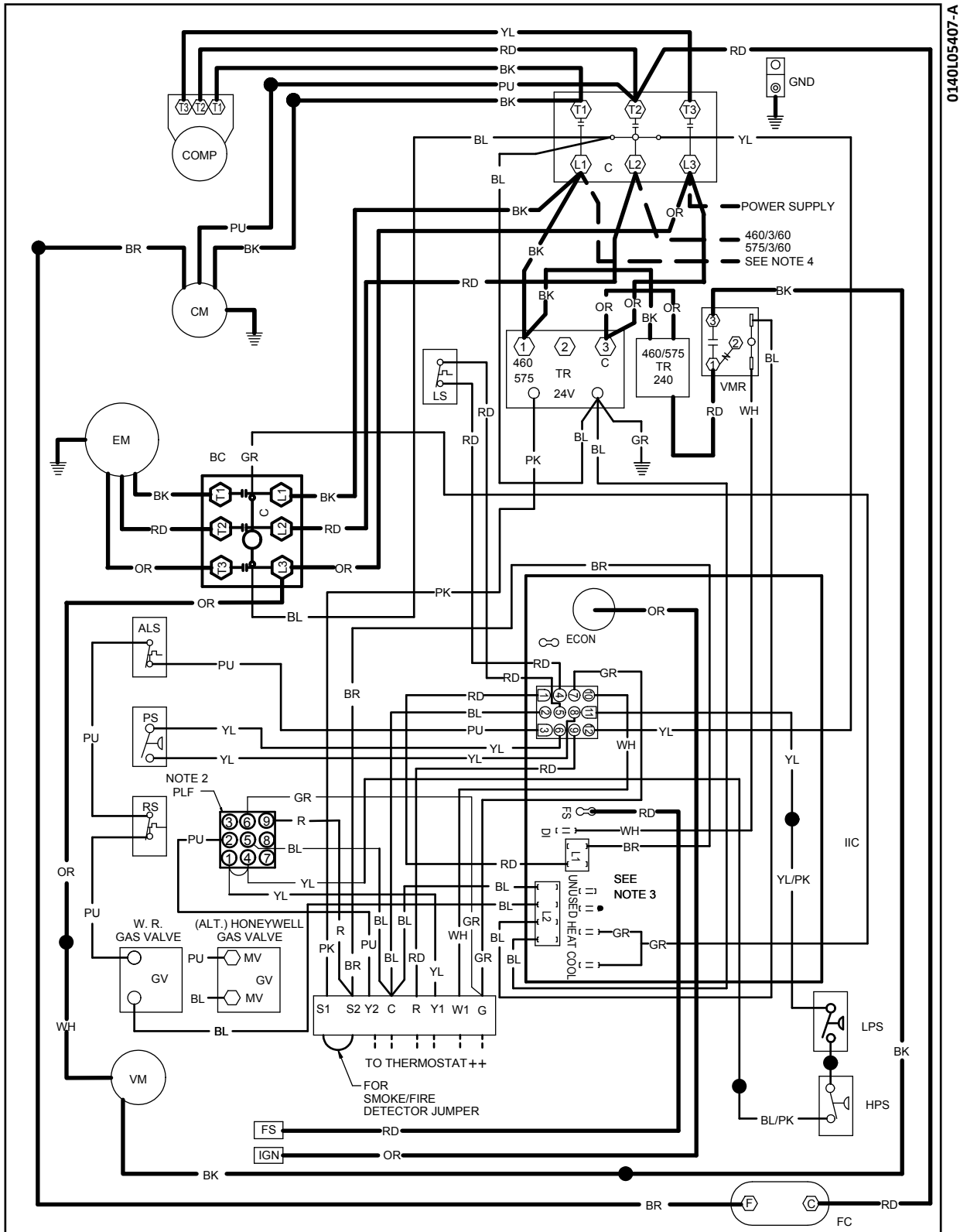

0140L05407-A

**High Voltage:** Disconnect all power before servicing or installing this unit. Multiple power sources may be present. Failure to do so may cause property damage, personal injury, or death.

**WARNING**

Wiring is subject to change. Always refer to the wiring diagram on the unit for the most up-to-date wiring.

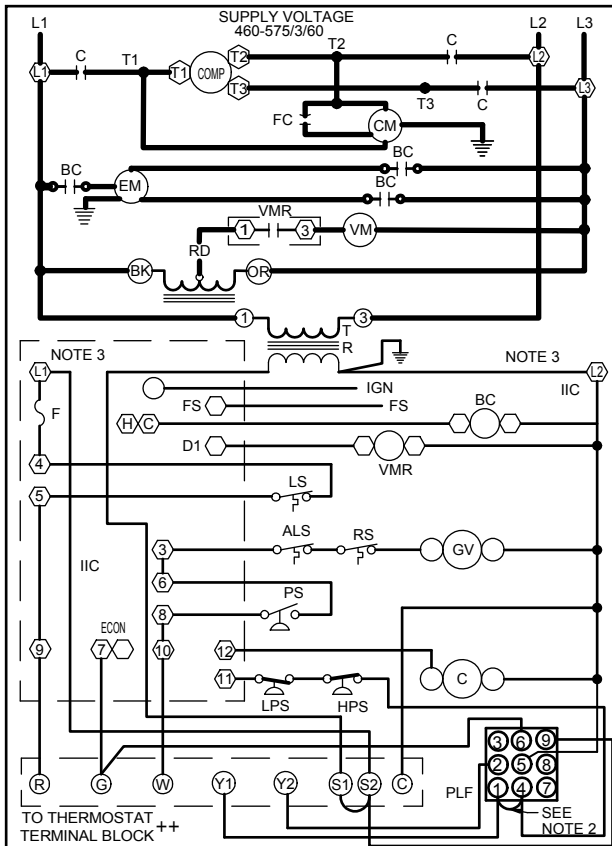

- COMPONENT LEGEND**
- ALS AUXILLARY LIMIT SWITCH
  - BC BLOWER CONTACTOR
  - COMP COMPRESSOR
  - CM CONDENSER MOTOR
  - C CONTACTOR
  - EM EVAPORATOR MOTOR
  - F FUSE
  - FC FAN CAPACITOR
  - FS FLAME SENSOR
  - GND EQUIPMENT GROUND
  - GV GAS VALVE
  - HPS HIGH PRESSURE SWITCH
  - IBR INDOOR BLOWER RELAY
  - IIC INTEGRATED IGNITION CONTROL
  - IGN IGNITOR
  - LPS LOW PRESSURE SWITCH
  - LS LIMIT SWITCH
  - PLF FEMALE PLUG/CONNECTOR
  - PS PRESSURE SWITCH
  - RS ROLLOUT SWITCH
  - TB1 TERMINAL BLOCK (24V SIGNAL)
  - TR TRANSFORMER
  - VM VENT MOTOR
  - VMR VENT MOTOR RELAY

- NOTES**
- REPLACEMENT WIRE MUST BE THE SAME SIZE AND TYPE OF INSULATION AS ORIGINAL. (USE COPPER CONDUCTOR ONLY).
  - ACCESSORY ECONOMIZER PLUG ADJACENT TO BLOWER HOUSING IN RETURN AIR COMPARTMENT. REMOVE MALE PLUG AND ATTACH FEMALE PLUG TO THE ECONOMIZER ACCESSORY.
  - L1 AND L2 ON IIC CONTROL IS 24V INPUT.
  - USE COPPER CONDUCTORS ONLY.
- ++ USE NEC CLASS 2 WIRE.

- FACTORY WIRING**
- LINE VOLTAGE
  - LOW VOLTAGE
  - OPTIONAL HIGH VOLTAGE
  - OPTIONAL LOW VOLTAGE
- FIELD WIRING**
- HIGH VOLTAGE
  - LOW VOLTAGE
- WIRE CODE**
- BK BLACK
  - BL BLUE
  - BR BROWN
  - GR GREEN
  - OR ORANGE
  - PK PINK
  - PU PURPLE
  - RD RED
  - WH WHITE
  - YL YELLOW
  - BL/PK BLUE WITH PINK STRIP
  - YL/PK YELLOW WITH PINK STRIP

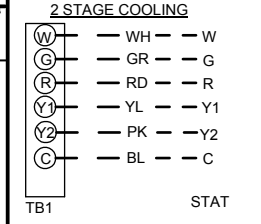
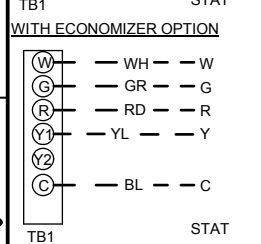
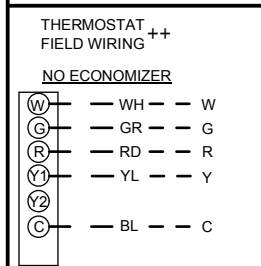

**INSTALLER/SERVICEMAN**  
THE STATUS LIGHT ON THE FURNACE CONTROL MAY BE USED AS A GUIDE TO TROUBLESHOOTING THIS APPLIANCE. STATUS LIGHT CODES ARE AS FOLLOWS:

STATUS LIGHT	EQUIP. STATUS	CHECK
ON	NORMAL OPERATION	-
OFF	NO POWER OR INTERNAL CONTROL	CHECK INPUT POWER CHECK FUSE ON CONTROL REPLACE CONTROL
1 BLINK	IGNITION FAILURE OPEN ROLLOUT SWITCH OPEN AUX. LIMIT SWITCH	GAS FLOW GAS PRESSURE GAS VALVE FLAME SENSOR FLAME ROLLOUT BAD SWITCH AUX. LIMIT OPEN
2 BLINKS	PRESSURE SWITCH OPEN	CHECK PRESSURE SWITCH
3 BLINKS	PRESSURE SWITCH CLOSED WITHOUT INDUCER ON	CHECK PRESSURE SWITCH
4 BLINKS	OPEN LIMIT SWITCH	MAIN LIMIT OPEN BAD SWITCH
5 BLINKS	FALSE FLAME SENSED	STICKING GAS VALVE
6 BLINKS	COMPRESSOR OUTPUT DELAY	3 MIN. COMP. ANTI-CYCLE TIMER

- SYMBOLS**
- JUNCTION TERMINAL
  - INTERNAL TO INTEGRATED CONTROL
  - PLUG CONNECTION
  - SWITCH (PRESS.)
  - OVERCURRENT PROT. DEVICE
  - EQUIPMENT GROUND
  - FIELD GROUND
  - FIELD SPLICE
  - SWITCH (TEMP)
  - IGNITER

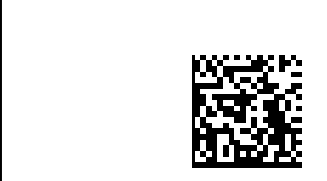

460-575/3/60 0140L05407-A

**High Voltage:** Disconnect all power before servicing or installing this unit. Multiple power sources may be present. Failure to do so may cause property damage, personal injury, or death.

**WARNING**

Wiring is subject to change. Always refer to the wiring diagram on the unit for the most up-to-date wiring.

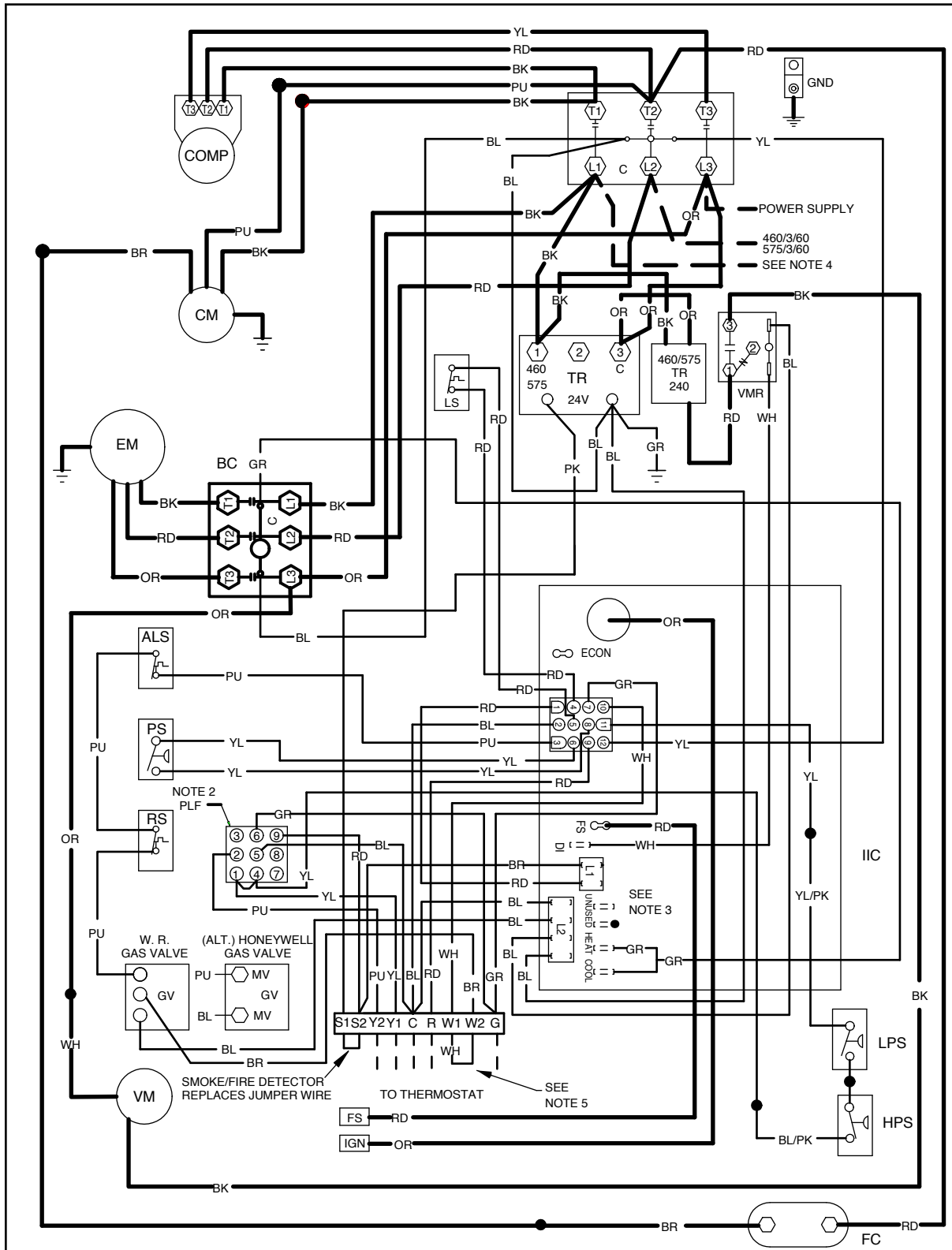

0140L05402-A

**High Voltage:** Disconnect all power before servicing or installing this unit. Multiple power sources may be present. Failure to do so may cause property damage, personal injury, or death.

**WARNING**

Wiring is subject to change. Always refer to the wiring diagram on the unit for the most up-to-date wiring.

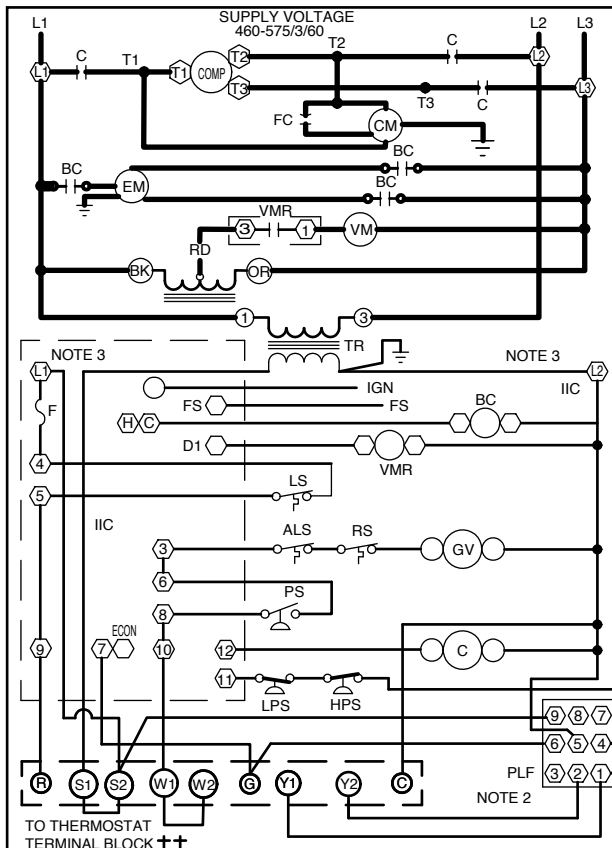

- COMPONENT LEGEND**
- ALS AUXILIARY LIMIT SWITCH
  - BC BLOWER CONTACTOR
  - COMP COMPRESSOR
  - CM CONDENSER MOTOR
  - C CONTACTOR
  - EM EVAPORATOR MOTOR
  - F FUSE
  - FC FAN CAPACITOR
  - FS FLAME SENSOR
  - GND EQUIPMENT GROUND
  - GV GAS VALVE
  - HPS HIGH PRESSURE SWITCH
  - IBR INDOOR BLOWER RELAY
  - IIC INTEGRATED IGNITION CONTROL
  - IGN IGNITOR
  - LPS LOW PRESSURE SWITCH
  - LS LIMIT SWITCH
  - PLF FEMALE PLUG/CONNECTOR
  - PS PRESSURE SWITCH
  - RS ROLLOUT SWITCH
  - TB1 TERMINAL BLOCK (24V SIGNAL)
  - TR TRANSFORMER
  - VM VENT MOTOR
  - VMR VENT MOTOR RELAY

- NOTES**
1. REPLACEMENT WIRE MUST BE THE SAME SIZE AND TYPE OF INSULATION AS ORIGINAL. (USE COPPER CONDUCTOR ONLY).
  2. ACCESSORY ECONOMIZER PLUG ADJACENT TO BLOWER HOUSING IN RETURN AIR COMPARTMENT. REMOVE MALE PLUG AND ATTACH FEMALE PLUG TO THE ECONOMIZER ACCESSORY.
  3. L1 AND L2 ON IIC CONTROL IS 24V INPUT.
  4. USE COPPER CONDUCTORS ONLY. ++ USE NEC CLASS 2 WIRE.
  5. FOR LOW STAGE OPERATION ONLY, REMOVE WHITE JUMPER. FOR 2 STAGE OPERATION, REMOVE JUMPER AND CONNECT W2 TO W2 ON THERMOSTAT.

- FACTORY WIRING**
- LINE VOLTAGE
  - LOW VOLTAGE
  - - - OPTIONAL HIGH VOLTAGE
- FIELD WIRING**
- - - HIGH VOLTAGE
  - - - LOW VOLTAGE
- WIRE CODE**
- BK BLACK
  - BL BLUE
  - BR BROWN
  - GR GREEN
  - OR ORANGE
  - PK PINK
  - PU PURPLE
  - RD RED
  - WH WHITE
  - YL YELLOW
  - BL/PK BLUE WITH PINK STRIP
  - YL/PK YELLOW WITH PINK STRIP

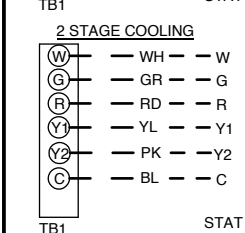
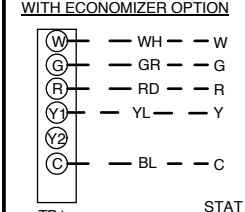
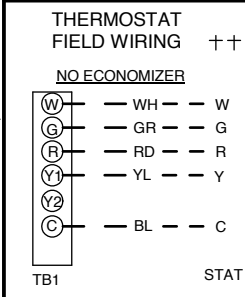

**INSTALLER/SERVICEMAN**  
 THE STATUS LIGHT ON THE FURNACE CONTROL MAY BE USED AS A GUIDE TO TROUBLESHOOTING THIS APPLIANCE. STATUS LIGHT CODES ARE AS FOLLOWS:

STATUS LIGHT	EQUIP. STATUS	CHECK
ON	NORMAL OPERATION	-
OFF	NO POWER OR INTERNAL CONTROL	CHECK INPUT POWER CHECK FUSE ON CONTROL REPLACE CONTROL
1 BLINK	IGNITION FAILURE OPEN ROLLOUT SWITCH OPEN AUX. LIMIT SWITCH	GAS FLOW GAS PRESSURE GAS VALVE FLAME SENSOR FLAME ROLLOUT BAD SWITCH AUX. LIMIT OPEN
2 BLINKS	PRESSURE SWITCH OPEN	CHECK PRESSURE SWITCH
3 BLINKS	PRESSURE SWITCH CLOSED WITHOUT INDUCER ON	CHECK PRESSURE SWITCH
4 BLINKS	OPEN LIMIT SWITCH FALSE FLAME	MAIN LIMIT OPEN BAD SWITCH
5 BLINKS	SENSED	STICKING GAS VALVE
6 BLINKS	COMPRESSOR OUTPUT DELAY	3 MIN. COMP. ANTI-CYCLE TIMER

SEE UNIT RATING PLATE FOR TYPE AND SIZE OF OVER CURRENT PROTECTION.



460-575/3/60 0140L05402-A

**High Voltage:** Disconnect all power before servicing or installing this unit. Multiple power sources may be present. Failure to do so may cause property damage, personal injury, or death.

**WARNING**

Wiring is subject to change. Always refer to the wiring diagram on the unit for the most up-to-date wiring.

---

***WIRING DIAGRAMS FOR MODELS WITH DDC CONTROLS ARE  
LOCATED IN SUPPLEMENT IODS1024\****

**FOR COMPLETE INFORMATION AND INSTALLATION INSTRUCTIONS FOR MODELS  
WITH DDC CONTROLS, SEE MANUAL DK-DDC-TGD-01\***

DAIKIN MASTER ITEM #	DESCRIPTION	FITS MODEL SIZES	FIELD-INSTALLED	FACTORY-INSTALLED	OPERATING WEIGHT (LBS)
	<b>Curb</b>				
14CURB3672B	14" Roof Curb	3-5 Tons	√		86
18CURB3672B	18" Roof Curb	3-5 Tons	√		100
24CURB3672B	24" Roof Curb	3-5 Tons	√		128
GHRC-3672	Hurricane Restraint Clips	3-5 Tons	√		2
	<b>Ultra Low-Leak Economizer &amp; Power Exhaust<sup>1</sup></b>				
1036609C	Ultra Low-Leak Downflow Economizer w/ Enthalpy	3-5 Tons	√	√	71
1039609	Ultra Low-Leak Horizontal Economizer w/ Enthalpy	3-5 Tons	√		71
104650921	Prop Power Exhaust 230v	3-5 Tons	√		55
104650931	Prop Power Exhaust 460v	3-5 Tons	√		55
104650941	Prop Power Exhaust 575v	3-5 Tons	√		55
	<b>Low-Leak Economizer &amp; Power Exhaust<sup>2</sup></b>				
DDNECNJ3672C	Low-Leak Downflow Economizer	3-5 Tons	√	√	82
DPE36722	Downflow Power Exhaust (208/230 Volt)	3-5 Tons	√		55
DPE36724	Downflow Power Exhaust (460 Volt)	3-5 Tons	√		55
DPE36727	Downflow Power Exhaust (575v)	3-5 Tons	√		55
DINH3672B	Horizontal Economizer, Internally Mounted	3-5 Tons	√		90
DHZECNJ3672	Horizontal Economizer	3-5 Tons	√		70
DHPE36722	Horizontal Power Exhaust (208/230 Volt)	3-5 Tons	√		55
DHPE36724	Horizontal Power Exhaust (460 Volt)	3-5 Tons	√		55
DHPE36727	Horizontal Power Exhaust (575 Volt)	3-5 Tons	√		55
	<b>Downflow Accessories</b>				
D25FD3672	25% Manual Fresh Air Damper	3-5 Tons	√		12
D25MFD3672	25% Motorized Fresh Air Damper	3-5 Tons	√		16
DDNBBS3672	Burglar Bar Sleeves with Supply & Return	3-5 Tons	√		30
DDNECNJ3672NR	Downflow Economizer <sup>2</sup> w/o Barometric Relief	3-5 Tons	√		77
DDNSQRD3616	Downflow Square-to-Round Adapter (16" Round)	3 tons	√		45
DDNSQRD487218	Downflow Square-to-Round Adapter (18" Round)	4-5 tons	√		35
	<b>Horizontal Accessories</b>				
DBRD3672	Barometric Relief Damper	3-5 Tons	√		15
	<b>Concentrics</b>				
CDK36	Concentric Duct Kit	3 Ton	√		27
CDK36515	Flush Mount Concentric Duct Kit w/ Filter	3 Ton	√		28
CDK36530	Step Down Concentric Duct Kit	3 Ton	√		27
CDK36535	Step Down Concentric Duct Kit w/ Filter	3 Ton	√		28
CDK4872	Concentric Duct Kit	4-5 Ton	√		27
CDK4872515	Flush Mount Concentric Duct Kit w/ Filter	4-5 Ton	√		28
CDK4872530	Step Down Concentric Duct Kit	4-5 Ton	√		27
CDK4872535	Step Down Concentric Duct Kit w/ Filter	4-5 Ton	√		28

DAIKIN MASTER ITEM #	DESCRIPTION	FITS MODEL SIZES	FIELD- INSTALLED	FACTORY- INSTALLED	OPERATING WEIGHT (LBS)
	<b>DDC Accessories<sup>3</sup></b>				
	DDC communicating controller (built-in BACnet® MS/TP) includes Standard Room Sensor to be installed in field	3-5 Tons		√	2
10366D09C	DDC Ultra Low-Leak Downflow Economizer	3-5 Tons	√	√	71
10396D09	DDC Ultra Low-Leak Horizontal Economizer	3-5 Tons	√		71
10465DDC	Power Exhaust kit used with DDC Ultra Low-Leak Economizer	3-5 tons	√		1
DLAKT01	Low-Ambient	3-5 Tons	√	√	2
LONKT01	LonWorks® card	3-5 Tons	√		1
3PMK01	Phase Monitor (3-Phase Only)	3-5 Tons	√	√	2
DFSKT01	Dirty Filter Switch	3-5 Tons	√		1
	<b>High-Static Kits<sup>4</sup></b>				
HSKTS036	High Static Kit - 230v & 460v	DS*, 3 Ton	√	√	2
HSKTS048	High Static Kit - 230v & 460v	DS*, 4 Ton	√	√	38
HSKTS060	High Static Kit - 230v & 460v	DS*, 5 Ton	√	√	38
HSKTS036-7	High Static Kit - 575v	DS*, 3 Ton	√	√	2
HSKTS048-7	High Static Kit - 575v	DS*, 4 Ton	√	√	5
HSKTS060-7	High Static Kit - 575v	DS*, 5 Ton	√	√	38
	<b>Crankcase Heater Kits</b>				
0163R00002S	40W 230V	3 tons	√		1
0163R00031S	40W 460V	3 tons	√		1
0163R00032S	40W 575V	3 tons	√		1
0130L00017S	70W 230V	4 - 5 tons	√		1
0130L00018S	70W 460V	4 - 5 tons	√		1
0130L00019S	70W 575V	4 - 5 tons	√		1
	<b>High Efficiency Filters</b>				
0160L00203	High Efficiency MERV 13 Air Filter Nom. Size: 24x24x2; (Order Qty 1)	3 tons	√		2
0160L00204	High Efficiency MERV 13 Air Filter Nom. Size: 14x20x2; (Order Qty 4)	4 tons	√		4
0160L00205	High Efficiency MERV 13 Air Filter Nom. Size: 16x20x2; (Order Qty 4)	5 tons	√		4
	<b>Misc Accessories</b>				
HAILGD03D	Condenser Coil Hail Guard	3-4 tons	√		19
HAILGD04D	Condenser Coil Hail Guard	5 tons	√		19
	Convenience Outlet: Non Powered	3-5 tons		√	2
	Convenience Outlet: Powered	3-5 tons		√	42
	Disconnect Switch	3-5 tons		√	5
LAKT11	Low Ambient Kit, 208-230V - non-DDC	3-5 tons	√	√	14
LAKT13	Low Ambient Kit, 460V - non-DDC	3-5 tons	√	√	14
LAKT14	Low Ambient Kit, 575V - non-DDC	3-5 tons	√	√	14
3PMNDK01	Phase Monitor - Non DDC	3-5 Ton	√	√	2

DAIKIN MASTER ITEM #	DESCRIPTION	FITS MODEL SIZES	FIELD- INSTALLED	FACTORY- INSTALLED	OPERATING WEIGHT (LBS)
	Smoke Detector (supply and/or return air)	3-5 Ton		√	11
	Hinged Panels	3-5 Ton		√	10
FSK01A	Freeze Stat Kit	3-5 Ton	√		1
IRKT-01	Isolation Relay Kit	3-5 Ton	√		2
LPM-07	LP Conversion Kit (For DSG036045 unit only)	3 Ton	√		1
LPM-06	LP Conversion Kit	3-5 Ton	√		1
220-GX-01	Flue Extension Kit	3-5 Ton	√		2
HA036300	High Altitude Kit	3-5 Ton	√		2

<sup>1</sup> Use Economizer & Power Exhaust listed within Ultra Low-Leak section  
<sup>2</sup> Use Economizer & Power Exhaust listed within Low-Leak section  
<sup>3</sup> For a full list of DDC accessories, please refer to DDC Controller Technical Guide manual (DK-DDC-TGD-01B)  
<sup>4</sup> HSKT High-Static Kits are for use with standard single-speed belt-drive units only.  
**Note:** Where multiple variations are available, the heaviest combination is listed.