



# DCH COMMERCIAL

## 7½ - 12½ TON PACKAGED HEAT PUMP UP TO 11.5 EER & 3.4 COP

Cooling Capacity: 90,000 — 140,000 BTU/h

Heating Capacity: 90,000 — 142,000 BTU/h



\*Model shown is a gas/electric

### ■ Contents

Nomenclature.....	2
Product Specifications .....	4
Expanded Cooling Data.....	8
Expanded Heating Data .....	16
Airflow Data.....	18
Crankcase Heater.....	22
Electrical Data / Heat Kit Data ...	23
Dimensions .....	31
Wiring Diagrams .....	35
– for Models with DDC Controls.....	39
Accessories .....	42

### ■ Standard Features

- High-efficiency scroll compressors
- Two-stage cooling
- Copper tube / aluminum fin coils
- Power block for field wiring
- High-capacity, steel-cased filter drier
- Single-point entry
- 24-volt terminal strip
- Convertible airflow orientation
- Easy to service
- Built-in filter rack with standard 2” filters
- AHRI Certified; ETL Listed
- Units meet the performance outlined in Table 6.8.1-2 of ASHRAE Standard 90.1-2013

### ■ Cabinet Features

- Heavy-gauge, galvanized-steel cabinet with UV-resistant powder-paint finish
- Full perimeter rail
- Sloped drain pan



\* Complete warranty details available from your local dealer or at [www.daikincomfort.com](http://www.daikincomfort.com).

	D	C	H	090	045	3	V	*	*	*	A	*
	1	2	3	4,5,6	7,8,9	10	11	12	13	14	15	16
<b>REVISION LEVELS</b>												
Major & Minor												
<b>FACTORY-INSTALLED OPTIONS</b>												
<b>BRAND</b>	D Daikin											
<b>CONFIGURATION</b>	C Standard Efficiency (6 - 25 Tons) S Standard Efficiency (3 - 5 Tons) T High Efficiency (3 - 5 Tons)											
<b>APPLICATION</b>	C Cooling <sup>1</sup> G Gas Heat H Heat Pump <sup>1</sup>											
<b>NOMINAL COOLING CAPACITY</b>	036 3 Tons      102 8½ Tons      300 25 Tons 048 4 Tons      120 10 Tons 060 5 Tons      150 12½ tons 072 6 Tons      180 15 Tons 090 7½ Tons      240 20 Tons											
<b>NOMINAL HEATING CAPACITY</b>	Gas/Electric      A/C H/P Factory-Installed Electric Heat 045 45,000 BTU/h      XXX No Heat 090 90,000 BTU/h      010 10 kW      030 30 kW 115 115,000 BTU/h      015 15 kW      031 30 kW 140 140,000 BTU/h      016 15 kW      045 45 kW 210 210,000 BTU/h      018 18 kW      046 45 kW 350 350,000 BTU/h      020 20 kW      060 60 kW 400 400,000 BTU/h      025 25 kW											
See product specifications for heat size(s) available for each capacity.												
<b>VOLTAGE</b>	1 208-230/1/60 (DS* & DT* 3-5 Tons models only)      4 460/3/60 3 208-230/3/60      7 575/3/60											
<b>SUPPLY FAN/DRIVE TYPE/MOTOR</b>	B Belt Drive (3-5 Tons single speed models only)      V Two-Speed Belt Drive (6-25 Tons only) D Direct Drive (3-5 Tons single speed models only) H High Static (3-5 Tons single-speed Belt Drive models only)      W High Static (6-25 Tons two-speed Belt Drive models only)											
<b>FACTORY-INSTALLED OPTIONS</b>												
A	Ultra Low-Leak Downflow Economizer											
B	DDC-BACnet protocol											
F	Ultra Low-Leak Downflow Economizer; DDC-BACnet protocol											
H	Disconnect Switch (non-fused)											
J	Ultra Low-Leak Downflow Economizer; Disconnect Switch (non-fused)											
M	Disconnect Switch (non-fused); DDC-BACnet protocol											
R	Ultra Low-Leak Downflow Economizer; DDC-BACnet protocol; Disconnect Switch (non-fused)											
V	Low-Leak Downflow Economizer											
W	Low-Leak Downflow Economizer Disconnect Switch (non-fused)											
X	No Options											
<b>FACTORY-INSTALLED OPTIONS</b>												
X	Standard Aluminized Heat Exchanger											
S	Stainless-Steel Heat Exchanger											
D	Hinged Panels											
K	Stainless-Steel Heat Exchanger; Hinged Panels											
B	Phase Monitor											
J	Stainless Steel Heat Exchanger; Phase Monitor											
M	Hinged Panel; Phase Monitor											
L	Stainless-Steel Heat Exchanger; Hinged Panels; Phase Monitor											
X	No Options											
A	Non-powered convenience outlet											
B	Powered convenience outlet											
C	Low-ambient kit											
D	Return air smoke detector											
E	Supply air smoke detector											
F	Non-powered convenience outlet; Low-ambient kit											
G	Non-powered convenience outlet; Return air smoke detector											
H	Non-powered convenience outlet; Supply air smoke detector											
J	Non-powered convenience outlet; Return & Supply air smoke detectors											
K	Non-powered convenience outlet; Low-ambient kit; Supply air smoke detector											
L	Non-powered convenience outlet; Low-ambient kit Return & Supply air smoke detectors											
M	Powered convenience outlet; Low-ambient kit											
N	Powered convenience outlet; Return air smoke detector											
O	Powered convenience outlet; Return & Supply air smoke detectors											
P	Powered convenience outlet; Supply air smoke detector											
Q	Powered convenience outlet; Low-ambient kit; Return air smoke detector											
R	Powered convenience outlet; Low-ambient kit; Supply air smoke detector											
T	Powered convenience outlet; Low-ambient kit; Return & Supply air smoke detectors											
U	Non-powered convenience outlet; Low-ambient kit; Return air smoke detector											
V	Low-ambient kit; Return air smoke detector											
W	Low-ambient kit; Supply air smoke detector											
Y	Low-ambient kit; Return & Supply air smoke detectors											
Z	Return & Supply air smoke detectors											

Note: Not all options available for all products.

<sup>1</sup>X= No Options in character 13th

**FACTORY-INSTALLED OPTIONS**

- **Stainless-Steel Heat Exchanger (Gas units only):** A tubular heat exchanger made of 409-type stainless steel is installed in the unit.
- **Low-Ambient Kit:** Allows for cooling operation at lower outdoor temperatures. On the 3- to 6-ton units, cooling operation is extended from 60°F ambient temperature to 35°F outside air temperature. On 7½ -20 ton units, cooling operation is extended from 35°F ambient temperature to 0°F outside air temperature. For 25 ton units, cooling operation is extended from 24°F ambient temperature to 0°F outside air temperature.
- **Economizers (Downflow):** Based on air conditions, can provide outside air to cool the space.
- **Electric Heat Kits (AC and heat pump units only):** Available in all voltage options.
- **Non-powered Convenience Outlet:** A 120V, 15A, GFCI outlet makes it easier for technicians to service the unit once an electrician runs power to the outlet.
- **Powered Convenience Outlet:** A 120V, 15A, GFCI outlet powered with a transformer built into the unit. When a factory-installed powered convenience outlet is installed in the equipment, the unit MCA (Min. Circuit Ampacity) will increase by 7.2A/6.5A for 208/230V units, increase by 3.3A for 460V units, and by 2.6A for 575V units. The MOP (Max. Overcurrent Protection) device must be sized accordingly.
- **Disconnect Switch (non-fused; 3-phase units only):** A disconnect switch is installed in the unit and factory wiring will be complete from the switch to the unit. Please note that for air conditioning (DSC units) and heat pump models (DSH units), the appropriate electric heat kit must be ordered to be factory-installed along with the disconnect switch (non-fused) when it is ordered. Please note that for models with a powered convenience outlet option and a disconnect switch (non-fused) option, the power to the powered convenience outlet will be shut off when the disconnect switch (non-fused) is in the off position.
- **Return Air and/or Supply Air Smoke Detectors:** Return air and/or supply air smoke detectors are installed in the unit.
- **Hinged Access Panels:** Allows access to unit's major components. Combined with latches for easy access to control box, compressor, filters and blower motor. Available on all units.
- **Phase Monitor:** Phase monitor (3 phase only), available for 3 - 25 ton DS, DC and DT series models. Phase monitor shall provide protection for motors and compressors against problems caused by phase loss, phase reversal and phase unbalance. Phase monitor is equipped with an LED that provides an ON or FAULT indicator.
- **DDC Controller:** DDC communicating controller, available for 3 - 25 ton DS, DC and DT series models with on-board BACnet® communication interface.
- **High static belt drive assembly, factory installed.**

	DCH090 ***3V***A*	DCH090 ***4V***A*	DCH090 ***7V***A*
<b>Cooling Capacity</b>			
Total BTU/h	90,000	90,000	90,000
Sensible BTU/h	65,700	65,700	65,700
EER / IEER	11.5 / 12.8	11.5 / 12.8	11.5 / 12.8
Decibels	83	83	83
AHRI Reference #s	7041912	7041912	7041912
<b>Heating Capacity</b>			
BTU/h / COP (47° F)	90,000 / 3.4	90,000 / 3.4	90,000 / 3.4
BTU/h / COP (17° F)	52,000 / 2.4	52,000 / 2.4	52,000 / 2.4
<b>Evaporator Motor / Coil</b>			
Motor Type	2-speed Belt Drive	2-speed Belt Drive	2-speed Belt Drive
Indoor Nominal CFM	3,000	3,000	3,000
Indoor Motor FLA (Cooling)	6.0	2.9	2.4
Horsepower - RPM	2.0/1740-1160	2.0/1740-1160	2.0/1745-1170
Piston Size (Cooling)	0.076	0.076	0.078
Filter Size (Qty)	(4) 16" x 24" x 2"	(4) 16" x 24" x 2"	(4) 16" x 24" x 2"
Drain Size (NPT)	¾"	¾"	¾"
R-410A Refrigerant Charge: Cir #1/ #2	220 oz.	220 oz.	200 oz.
Evaporator Coil Face Area (ft²)	10.2	10.2	10.2
Rows Deep / Fins per Inch	4/16	4/16	4/16
<b>Belt Drive Evap Fan Data</b>			
# of Wheels (D x W)	1 (15" x 12")	1 (15" x 12")	1 (15" x 12")
Motor Sheave / Blower Sheave	VL40 / AK74	VL40 / AK74	VL40 / AK74
Belt	AX51	AX51	AX51
<b>Condenser Fan / Coil</b>			
Quantity of Condenser Fan Motors	2	2	2
Horsepower - RPM	¼ - 1090	¼ - 890	¼ - 1075
Fan Diameter / # Fan Blades	22 / 4	22 / 4	22 / 4
Outdoor Nominal CFM	0	0	0
Face Area (ft²)	7,600	7,600	7,600
# Coils / Rows Deep - Fins per Inch	2/2/20	2/2/20	2/2/20
Piston Size (Heating)	0.052	0.052	0.052
<b>Compressor</b>			
Quantity / Type / Stage	2 / Scroll / 1	2 / Scroll / 1	2 / Scroll / 1
Compressor RLA / LRA	13.1 / 83.1	6.1 / 41.0	4.4 / 33.0
<b>Electrical Data</b>			
Voltage / Phase / Frequency	208/230-3-60	460-3-60	575-3-60
Indoor Blower HP / FLA	2/6.0	2/2.9	2/2.4
Max External Static	1.0"	1.0"	1.0"
Outdoor Fan HP / FLA	¼ / 1.4	¼ / 0.7	¼ / 0.55
Min. Circuit Ampacity <sup>1</sup>	38.4 / 38.4	18	13.4
Max. Overcurrent Protection (amps) <sup>2</sup>	50 / 50	20	15
Entrance Power Supply & Entrance Control Voltage	Locating Dimple	Locating Dimple	Locating Dimple
<b>Operating Weight (lbs)</b>	1,135	1,135	1,135
<b>Ship Weight (lbs)</b>	1,175	1,175	1,175

<sup>1</sup> Wire size should be determined in accordance with National Electrical Codes. Extensive wire runs will require larger wire sizes.

<sup>2</sup> May use fuses or HACR-type circuit breakers of the same size as noted.

**NOTE:** Always check the S&R plate for electrical data on the unit being installed.

	DCH102 ***3V***A*	DCH102 ***4V***A*	DCH102 ***7V***A*
<b>COOLING CAPACITY</b>			
Total, BTU/h	100,000	100,000	100,000
Sensible BTU/h	69,000	69,000	69,000
EER / IEER	11.1 / 13.0	11.1 / 13.0	11.1 / 13.0
Decibels	83	83	83
ARI Reference #s	7370925	7370925	7370925
<b>HEATING CAPACITY</b>			
BTU/h / COP (47° F)	102,000 / 3.4	102,000 / 3.4	102,000 / 3.4
BTU/h / COP (17° F)	55,500 / 2.25	55,500 / 2.25	55,500 / 2.25
<b>EVAPORATOR MOTOR / COIL</b>			
Motor Type	2-speed Belt Drive	2-speed Belt Drive	2-speed Belt Drive
Indoor Nominal CFM	3,400	3,400	3,400
Indoor Motor FLA (Cooling)	6.0	2.9	2.4
Horsepower - RPM	2.0/1740-1160	2.0/1740-1160	2.0/1745-1170
Piston Size (Cooling)	0.08	0.08	0.08
Filter Size (in.) (Qty)	(4) 16 x 24 x 2	(4) 16 x 24 x 2	(4) 16 x 24 x 2
Drain Size (NPT)	3/4"	3/4"	3/4"
R-410A Refrigerant Charge Cir #1 & #2 (oz.)	235/225	235/225	235/225
Evaporator Coil Face Area (ft <sup>2</sup> )	10.2	10.2	10.2
Rows Deep / Fins per Inch	4 / 14	4 / 14	4 / 14
<b>BELT DRIVE EVAP FAN DATA</b>			
# of Wheels (D x W)	1 (15" x 12")	1 (15" x 12")	1 (15" x 12")
Motor Sheave / Blower Sheave	VL40 / AK74	VL40 / AK74	VL40 / AK74
Belt	AX51	AX51	AX51
<b>CONDENSER FAN / COIL</b>			
Quantity of Condenser Fan Motors	2	2	2
Horsepower - RPM	1/4" - 1,090	1/4" - 890	1/4" - 1,075
Fan Diameter / # Fan Blades	22 / 4	22 / 4	22 / 4
Outdoor Nominal CFM	7,600	7,600	7,600
Face Area (ft <sup>2</sup> )	32.4	32.4	32.4
Rows Deep / Fins per Inch	2 / 22	2 / 22	2 / 22
Piston Size (Heating)	0.059	0.059	0.059
<b>COMPRESSOR</b>			
Quantity / Type / Stage	2 / Scroll / 1	2 / Scroll / 1	2 / Scroll / 1
Compressor RLA / LRA ea.	14.5 / 98	6.3 / 55	6.0 / 41
<b>ELECTRICAL DATA / STATIC</b>			
Voltage / Phase / Frequency	208/230-3-60	460-3-60	575-3-60
Standard Motor Max. External Static	1"	1"	1"
Outdoor Fan FLA ea.	1.4	0.7	0.55
Min. Circuit Ampacity <sup>1</sup>	43.2 / 43.2	19.4	17.8
Max. Overcurrent Protection (amps) <sup>2</sup>	50 / 50	25	20
Entrance Power Supply & Control Voltage	Locating Dimple	Locating Dimple	Locating Dimple
<b>OPERATING WEIGHT (LBS)</b>	1,285	1,285	1,285
<b>SHIP WEIGHT (LBS)</b>	1,310	1,310	1,310

<sup>1</sup> Wire size should be determined in accordance with National Electrical Codes. Extensive wire runs will require larger wire sizes.

<sup>2</sup> May use fuses or HACR-type circuit breakers of the same size as noted.

**NOTE:** Always check the S&R plate for electrical data on the unit being installed.

	DCH120 ***3V***A*	DCH120 ***4V***A*	DCH120 ***7V***A*
<b>COOLING CAPACITY</b>			
Total BTU/h	113,000	113,000	113,000
Sensible BTU/h	84,700	84,700	84,700
EER / IEER	11.1 / 12.6	11.1 / 12.6	11.1 / 12.6
Decibels	83	83	83
ARI Reference #s	6345706	6345706	6345706
<b>HEATING CAPACITY</b>			
BTU/h / COP (47° F)	116,000 / 3.4	116,000 / 3.4	116,000 / 3.4
BTU/h / COP (17° F)	56,000 / 2.4	56,000 / 2.4	56,000 / 2.4
<b>EVAPORATOR MOTOR / COIL</b>			
Motor Type	2-speed Belt Drive	2-speed Belt Drive	2-speed Belt Drive
Indoor Nominal CFM	3,500	3,500	3,500
Indoor motor FLA (Cooling)	6.4	3.0	2.4
Horsepower - RPM	2.0/1725	2.0/1750-1165	2.0/1750-1165
Piston Size (Cooling)	0.086	0.086	0.086
Expansion Device	Orifice	Orifice	Orifice
Filter Size (in.) (Qty = 4)	16 x 24 x 2	16 x 24 x 2	16 x 24 x 2
Drain Size (NPT)	¾"	¾"	¾"
R-410A Refrigerant Charge Cir #1 & #2 (oz.)	225 / 225	225 / 225	225 / 225
Evaporator Coil Face Area (ft²)	10.2	10.2	10.2
Rows Deep/ Fins per Inch	4 / 14	4 / 14	4 / 14
<b>BELT DRIVE EVAP FAN DATA</b>			
# of Wheels (D x W)	(1) 15" x 15"	(1) 15" x 15"	(1) 15" x 15"
Motor Sheave / Blower Sheave	VL40 / AK74	VL40 / AK74	VL40 / AK74
Belt	AX50	AX50	AX50
<b>CONDENSER FAN / COIL</b>			
Quantity of Condenser Fan Motors	2	2	2
Horsepower - RPM	½ - 1,075	½ - 1,075	½ - 1,075
Fan Diameter / # Fan Blades	22 / 3	22 / 3	22 / 3
Outdoor Nominal CFM	8,200	8,200	8,200
Face Area (ft²)	32.4	32.4	32.4
# Coils / Rows Deep - Fins per Inch	2 / 2 - 22	2 / 2 - 22	2 / 2 - 22
Piston Size (Heating)	0.064	0.064	0.064
<b>COMPRESSOR</b>			
Quantity / Type / Stage	2 / Scroll / 1	2 / Scroll / 1	2 / Scroll / 1
Compressor RLA / LRA ea.	16 / 110.0	7.8 / 52.0	5.7 / 38.9
<b>ELECTRICAL DATA</b>			
Voltage/Phase/ Frequency	208/230-3-60	460-3-60	575-3-60
Belt-Driven Standard Max Static	1.4	1.4	1.4
Outdoor Fan RLA ea.	2.00	0.85	0.85
Min. Circuit Ampacity <sup>1</sup>	46.3 / 46.3	22.2	16.6
Max. Overcurrent Protection (amps) <sup>2</sup>	60 / 60	25	20
Entrance Power Supply & Control Voltage	Locating Dimple	Locating Dimple	Locating Dimple
<b>OPERATING WEIGHT (LBS)</b>	1285	1285	1285
<b>SHIP WEIGHT (LBS)</b>	1310	1310	1310

<sup>1</sup> Wire size should be determined in accordance with National Electrical Codes. Extensive wire runs will require larger wire sizes.

<sup>2</sup> May use fuses or HACR-type circuit breakers of the same size as noted.

**NOTE:** Always check the S&R plate for electrical data on the unit being installed.

	DCH150 ***3V***A*	DCH150 ***4V***A*	DCH150 ***7V***A*
<b>COOLING CAPACITY</b>			
Total, BTU/h	140,000	140,000	140,000
Sensible BTU/h	98,000	98,000	98,000
EER / IEER	10.6 / 11.8	10.6 / 11.8	10.6 / 11.8
Decibels	83	83	83
ARI Reference #s	6885866	6885866	6885866
<b>HEATING CAPACITY</b>			
BTU/h / COP (47° F)	142,000 / 3.2	142,000 / 3.2	142,000 / 3.2
BTU/h / COP (17° F)	82,000 / 2.1	82,000 / 2.1	82,000 / 2.1
<b>EVAPORATOR MOTOR / COIL</b>			
Motor Type	2-speed Belt Drive	2-speed Belt Drive	2-speed Belt Drive
Indoor Nominal CFM	4,000	4,000	4,000
Indoor Motor FLA (Cooling)	9.1	4.3	3.5
Horsepower - RPM	3.0/1760-1165	3.0/1760-1165	3.0/1760-1165
Piston Size (Cooling)	0.094	0.094	0.094
Filter Size (in.) (Qty)	(4) 20 x 25 x 2	(4) 20 x 25 x 2	(4) 20 x 25 x 2
Drain Size (NPT)	¾"	¾"	¾"
R-410A Refrigerant Charge Cir #1 & #2 (oz.)	301 / 301	301 / 301	301 / 301
Evaporator Coil Face Area (ft <sup>2</sup> )	14.7	14.7	14.7
Rows Deep / Fins per Inch	4/7	4/7	4/7
<b>BELT DRIVE EVAP FAN DATA</b>			
# of Wheels (D x W)	(1) 15" x 15"	(1) 15" x 15"	(1) 15" x 15"
Motor Sheave / Blower Sheave	VP44 / AK71	VP44 / AK71	VP44 / AK71
Belt	AX48	AX48	AX48
<b>CONDENSER FAN / COIL</b>			
Quantity of condenser Fan Motors	2.0	2.0	2.0
Horsepower - RPM	½ - 1,075	½ - 1,075	½ - 1,075
Fan Diameter / # Fan Blades	22/ 3	22/ 3	22/ 3
Outdoor Nominal CFM	8,200	8,200	8,200
Face Area (ft <sup>2</sup> )	35.3	35.3	35.3
# Coils / Rows Deep - Fins per Inch	2/3-15	2/3-15	2/3-15
Piston Size (Heating)	0.07	0.07	0.07
<b>COMPRESSOR</b>			
Quantity / Type/ Stage	2 / Scroll / 1	2 / Scroll / 1	2 / Scroll / 1
Compressor RLA / LRA ea.	22.4 / 149	10.6 / 75	7.7 / 54
<b>ELECTRICAL DATA / STATIC</b>			
Voltage / Phase / Frequency	208/230-3-60	460-3-60	575-3-60
Standard Max Static	1.4"	1.4"	1.4"
Outdoor Fan FLA ea.	2.0	0.85	0.67
Min. Circuit Ampacity <sup>1</sup>	63.6 / 63.6	29.8	22.2
Max. Overcurrent Protection (amps) <sup>2</sup>	80 / 80	40	25
Entrance Power Supply & Entrance Control Voltage	Locating Dimple	Locating Dimple	Locating Dimple
<b>OPERATING WEIGHT (LBS)</b>	1325	1325	1325
<b>SHIP WEIGHT (LBS)</b>	1350	1350	1350

<sup>1</sup> Wire size should be determined in accordance with National Electrical Codes. Extensive wire runs will require larger wire sizes.

<sup>2</sup> May use fuses or HACR-type circuit breakers of the same size as noted.

**NOTE:** Always check the S&R plate for electrical data on the unit being installed.

		OUTDOOR AMBIENT TEMPERATURE																							
		65				75				85				95				105				115			
		ENTERING INDOOR WET BULB TEMPERATURE																							
IDB	AIRFLOW	59	63	67	71	59	63	67	71	59	63	67	71	59	63	67	71	59	63	67	71	59	63	67	71
<b>70</b>	MBh	88.2	91.4	100.2	-	86.1	89.3	97.8	-	84.1	87.2	95.5	-	82.0	85.0	93.2	-	77.9	80.8	88.5	-	72.2	74.8	82.0	-
	S/T	0.73	0.61	0.42	-	0.76	0.63	0.44	-	0.78	0.65	0.45	-	0.80	0.67	0.47	-	0.83	0.70	0.48	-	0.84	0.70	0.49	-
	ΔT	18	15	12	-	18	15	12	-	18	15	12	-	18	16	12	-	18	15	12	-	17	14	11	-
	kW	6.19	6.32	6.50	-	6.64	6.77	6.98	-	7.03	7.17	7.39	-	7.37	7.53	7.76	-	7.67	7.83	8.08	-	7.92	8.09	8.35	-
	Hi PR	234	252	266	-	262	282	298	-	298	321	339	-	340	366	386	-	382	411	434	-	422	454	480	-
	Lo PR	108	115	126	-	114	122	133	-	119	126	138	-	125	133	145	-	131	139	152	-	135	144	157	-
<b>70</b>	MBh	85.6	88.7	97.2	-	83.6	86.7	95.0	-	81.6	84.6	92.7	-	79.7	82.6	90.5	-	75.7	78.4	85.9	-	70.1	72.6	79.6	-
	S/T	0.70	0.58	0.40	-	0.72	0.61	0.42	-	0.74	0.62	0.43	-	0.77	0.64	0.44	-	0.80	0.66	0.46	-	0.80	0.67	0.46	-
	ΔT	18	16	12	-	19	16	12	-	19	16	12	-	19	16	12	-	18	16	12	-	17	15	11	-
	kW	6.15	6.27	6.45	-	6.59	6.72	6.92	-	6.98	7.12	7.34	-	7.32	7.47	7.70	-	7.61	7.77	8.01	-	7.86	8.03	8.28	-
	Hi PR	231	249	263	-	260	279	295	-	295	318	336	-	336	362	382	-	378	407	430	-	418	450	475	-
	Lo PR	107	114	124	-	113	120	132	-	118	125	137	-	124	132	144	-	130	138	150	-	134	143	156	-
<b>2400</b>	MBh	79.0	81.9	89.7	-	77.2	80.0	87.7	-	75.4	78.1	85.6	-	73.5	76.2	83.5	-	69.8	72.4	79.3	-	64.7	67.1	73.5	-
	S/T	0.67	0.56	0.39	-	0.70	0.58	0.40	-	0.72	0.60	0.41	-	0.74	0.62	0.43	-	0.77	0.64	0.44	-	0.77	0.65	0.45	-
	ΔT	20	18	13	-	21	18	14	-	21	18	14	-	21	18	14	-	21	18	13	-	19	17	13	-
	kW	6.01	6.13	6.31	-	6.44	6.57	6.76	-	6.81	6.95	7.16	-	7.15	7.29	7.52	-	7.43	7.58	7.82	-	7.67	7.83	8.08	-
	Hi PR	224	242	255	-	252	271	286	-	286	308	326	-	326	351	371	-	367	395	417	-	406	436	461	-
	Lo PR	104	111	121	-	110	117	128	-	114	121	133	-	120	128	139	-	126	134	146	-	130	138	151	-
<b>3375</b>	MBh	89.7	92.3	100.0	107.3	87.6	90.2	97.6	104.8	85.5	88.0	95.3	102.3	83.4	85.9	93.0	99.8	79.3	81.6	88.3	94.8	73.4	75.6	81.8	87.8
	S/T	0.83	0.75	0.56	0.36	0.86	0.77	0.58	0.38	0.89	0.79	0.60	0.39	0.91	0.82	0.62	0.40	0.95	0.85	0.64	0.41	0.96	0.86	0.65	0.42
	ΔT	20	19	15	11	21	19	16	11	21	19	16	11	21	19	16	11	20	19	15	11	19	18	14	10
	kW	6.24	6.36	6.55	6.75	6.69	6.82	7.03	7.25	7.08	7.23	7.45	7.69	7.43	7.59	7.83	8.07	7.73	7.89	8.14	8.40	7.99	8.16	8.42	8.69
	Hi PR	236	254	268	280	265	285	301	314	301	324	342	357	343	369	390	407	386	415	439	458	427	459	485	506
	Lo PR	109	116	127	135	116	123	134	143	120	128	139	149	126	134	146	156	132	141	154	163	137	145	159	169
<b>75</b>	MBh	87.1	89.7	97.0	104.1	85.1	87.6	94.8	101.7	83.0	85.5	92.5	99.3	81.0	83.4	90.3	96.9	77.0	79.2	85.8	92.0	71.3	73.4	79.4	85.3
	S/T	0.79	0.71	0.54	0.35	0.82	0.74	0.56	0.36	0.84	0.76	0.57	0.37	0.87	0.78	0.59	0.38	0.90	0.81	0.61	0.39	0.91	0.82	0.62	0.40
	ΔT	21	20	16	11	21	20	16	11	21	20	16	11	22	20	16	11	21	20	16	11	20	18	15	10
	kW	6.19	6.32	6.50	6.70	6.64	6.77	6.98	7.19	7.03	7.17	7.39	7.63	7.38	7.53	7.76	8.01	7.67	7.83	8.08	8.34	7.92	8.09	8.35	8.62
	Hi PR	234	252	266	277	262	282	298	311	298	321	339	354	340	366	386	403	382	411	434	453	422	454	480	501
	Lo PR	108	115	126	134	114	122	133	141	119	126	138	147	125	133	145	154	131	139	152	162	135	144	157	167
<b>2400</b>	MBh	80.4	82.7	89.6	96.1	78.5	80.8	87.5	93.9	76.6	78.9	85.4	91.7	74.8	77.0	83.3	89.4	71.0	73.1	79.2	85.0	65.8	67.7	73.3	78.7
	S/T	0.77	0.69	0.52	0.33	0.79	0.71	0.54	0.35	0.81	0.73	0.55	0.35	0.84	0.75	0.57	0.37	0.87	0.78	0.59	0.38	0.88	0.79	0.60	0.38
	ΔT	24	22	18	12	24	22	18	12	24	22	18	12	24	22	18	13	24	22	18	12	22	20	17	12
	kW	6.06	6.18	6.36	6.55	6.49	6.62	6.82	7.02	6.87	7.01	7.22	7.45	7.20	7.35	7.58	7.82	7.49	7.65	7.88	8.13	7.73	7.90	8.15	8.41
	Hi PR	227	244	258	269	254	274	289	302	289	311	329	343	330	355	375	391	371	399	421	439	410	441	466	486
	Lo PR	105	112	122	130	111	118	129	137	115	123	134	143	121	129	141	150	127	135	147	157	131	140	153	162

IDB: Entering Indoor Dry Bulb Temperature  
 High and low pressures are measured at the liquid and suction access fittings.  
 Design Superheat 7±2 °F, Design Subcooling 12 ±2 °F pressures measured @ the suction and liquid service ports, AHR1 95 test conditions  
 Shaded area reflects ACCA (TVA) Rating Conditions











IDB		OUTDOOR AMBIENT TEMPERATURE																													
		65					75					85					95					105					115				
		59	63	67	71	75	59	63	67	71	75	59	63	67	71	75	59	63	67	71	75	59	63	67	71	75	59	63	67	71	75
AIRFLOW		ENTERING INDOOR WET BULB TEMPERATURE																													
	MBh	118	120	128	137	115	117	125	134	112	115	122	131	109	112	119	128	104	106	114	121	96	98	105	112						
	S/T	0.91	0.86	0.70	0.5	0.95	0.89	0.72	0.5	1.00	0.91	0.74	0.6	1.00	0.94	0.77	0.6	1.00	1.00	0.79	0.6	1.00	1.00	0.80	0.6						
3938	ΔT	25.1	24.1	20.9	16.7	25.4	24.4	21.2	16.9	26.2	24.4	21.2	16.9	25.6	24.6	21.4	17.1	24.3	24.8	21.1	16.8	22.5	23.0	19.7	15.7						
	kW	8.34	8.49	8.73	9.0	8.90	9.07	9.32	9.6	9.39	9.57	9.85	10.1	9.83	10.02	10.31	10.6	10.20	10.40	10.71	11.0	10.52	10.73	11.05	11.4						
	Hi PR	252	271	286	299	283	304	321	335	322	346	366	381	366	394	416	434	412	444	468	489	455	490	517	540						
	Lo PR	107	114	124	132	113	120	131	140	117	125	136	145	123	131	143	152	129	137	150	160	134	142	155	165						
	MBh	114	117	125	133	112	114	122	130	109	111	119	127	106	109	116	124	101	103	110	118	94	96	102	109						
	S/T	0.87	0.82	0.67	0.50	0.90	0.85	0.69	0.52	0.93	0.87	0.71	0.53	0.96	0.90	0.73	0.55	0.99	0.93	0.76	0.57	1.00	0.94	0.76	0.57						
80	ΔT	26.16	25.07	21.80	17.4	26.48	25.38	22.07	17.6	26.51	25.40	22.09	17.6	26.69	25.58	22.24	17.8	26.32	25.22	21.93	17.5	24.56	23.56	20.49	16.4						
	kW	8.3	8.4	8.7	8.9	8.8	9.0	9.3	9.5	9.3	9.5	9.8	10.1	9.8	9.9	10.2	10.5	10.1	10.3	10.6	11.0	10.4	10.6	11.0	11.3						
	Hi PR	250	269	284	296	280	301	318	332	318	343	362	377	363	390	412	430	408	439	464	484	451	485	512	534						
	Lo PR	106	113	123	131	112	119	130	138	116	124	135	144	122	130	142	151	128	136	149	158	132	141	154	164						
	MBh	105	108	115	123	103	105	112	120	101	103	110	117	98	100	107	114	93	95	102	109	86	88	94	101						
	S/T	0.84	0.79	0.64	0.5	0.87	0.82	0.67	0.5	0.89	0.84	0.68	0.5	0.92	0.86	0.70	0.5	0.96	0.90	0.73	0.5	0.97	0.91	0.74	0.6						
2800	ΔT	29	28	24	19.4	29	28	25	19.6	29	28	25	19.6	30	28	25	19.8	29	28	24	19.5	27	26	23	18.2						
	kW	8.1	8.3	8.5	8.7	8.6	8.8	9.1	9.3	9.1	9.3	9.6	9.8	9.5	9.7	10.0	10.3	9.9	10.1	10.4	10.7	10.2	10.4	10.7	11.0						
	Hi PR	242	261	275	287	272	292	309	322	309	332	351	366	352	379	400	417	396	426	450	469	437	471	497	518						
	Lo PR	103	109	119	127	108	115	126	134	113	120	131	139	118	126	137	146	124	132	144	153	128	136	149	159						
	MBh	120	122	128	136	117	119	125	133	114	116	122	130	111	114	119	127	106	108	113	120	98	100	105	112						
	S/T	0.96	0.92	0.83	0.7	0.99	0.96	0.86	0.7	1.00	0.98	0.89	0.7	1.00	1.00	0.92	0.7	1.00	1.00	0.95	0.8	1.00	1.00	0.96	0.8						
3938	ΔT	26.8	26.3	24.9	21.6	27.1	26.7	25.2	21.8	26.7	26.7	25.2	21.8	26.0	26.5	25.4	22.0	24.7	25.2	25.1	21.7	22.9	23.3	23.4	20.3						
	kW	8.40	8.55	8.79	9.0	8.96	9.13	9.39	9.7	9.46	9.64	9.92	10.2	9.90	10.09	10.39	10.7	10.27	10.48	10.79	11.1	10.59	10.81	11.13	11.5						
	Hi PR	255	274	289	302	286	307	325	339	325	350	369	385	370	398	420	439	416	448	473	493	460	495	523	545						
	Lo PR	108	115	125	133	114	121	132	141	118	126	138	147	124	132	145	154	130	139	151	161	135	144	157	167						
	MBh	116	118	124	132	114	116	121	129	111	113	118	126	108	110	115	123	103	105	110	117	95	97	102	108						
	S/T	0.91	0.88	0.80	0.65	0.95	0.91	0.82	0.67	0.97	0.94	0.85	0.69	1.00	0.97	0.87	0.71	1.00	1.00	0.91	0.74	1.00	1.00	0.91	0.74						
3500	ΔT	27.90	27.44	25.94	22.5	28.24	27.78	26.26	22.7	28.27	27.81	26.28	22.8	28.40	28.00	26.47	22.9	26.98	27.50	26.10	22.6	24.99	25.47	24.38	21.1						
	kW	8.3	8.5	8.7	9.0	8.9	9.1	9.3	9.6	9.4	9.6	9.8	10.1	9.8	10.0	10.3	10.6	10.2	10.4	10.7	11.0	10.5	10.7	11.0	11.4						
	Hi PR	252	271	286	299	283	304	321	335	322	346	366	381	366	394	416	434	412	444	468	489	455	490	517	540						
	Lo PR	107	114	124	132	113	120	131	140	117	125	136	145	123	131	143	152	129	137	150	160	134	142	155	165						
	MBh	107	109	115	122	105	107	112	119	102	104	109	116	100	102	107	114	95	97	101	108	88	90	94	100						
	S/T	0.88	0.85	0.77	0.6	0.91	0.88	0.80	0.6	0.94	0.90	0.82	0.7	0.97	0.93	0.84	0.7	1.00	0.97	0.87	0.7	1.00	0.98	0.88	0.7						
2800	ΔT	31.0	30.5	28.9	25.0	31.4	30.9	29.2	25.3	31.5	30.9	29.2	25.3	31.7	31.2	29.4	25.5	31.1	30.7	29.0	25.1	28.8	28.7	27.1	23.5						
	kW	8.2	8.3	8.5	8.8	8.7	8.9	9.1	9.4	9.2	9.4	9.6	9.9	9.6	9.8	10.1	10.4	10.0	10.2	10.5	10.8	10.3	10.5	10.8	11.1						
	Hi PR	244	263	278	290	274	295	312	325	312	336	355	370	355	382	404	421	400	430	454	474	442	475	502	524						
	Lo PR	104	110	120	128	109	116	127	135	114	121	132	141	120	127	139	148	125	133	145	155	130	138	150	160						

IDB: Entering Indoor Dry Bulb Temperature  
 High and low pressures are measured at the liquid and suction access fittings.  
 Design Superheat 7±2 °F, Design Subcooling 12 ±2 °F, pressures measured @ the suction and liquid service ports, AHRI 95 test conditions  
 Shaded area reflects AHRI Rating Conditions



IDB		OUTDOOR AMBIENT TEMPERATURE																													
		65					75					85					95					105					115				
		59	63	67	71	75	59	63	67	71	75	59	63	67	71	75	59	63	67	71	75	59	63	67	71	75	59	63	67	71	75
AIRFLOW		ENTERING INDOOR WET BULB TEMPERATURE																													
4500	MBh	142.0	145.1	155.0	165.7	138.7	141.7	151.4	161.9	135.4	138.3	147.8	158.0	132.1	135.0	144.2	154.1	125.5	128.2	137.0	146.4	116.2	118.8	126.9	135.7						
	S/T	0.88	0.82	0.67	0.50	0.91	0.85	0.69	0.52	0.93	0.87	0.71	0.53	0.96	0.90	0.73	0.55	1.00	0.94	0.76	0.57	1.00	0.94	0.77	0.57						
	ΔT	25	24	21	17	26	25	21	17	26	25	21	17	26	25	22	17	26	25	21	17	24	23	20	16						
	kW	10.44	10.66	11.00	11.36	11.25	11.50	11.87	12.26	11.97	12.23	12.64	13.06	12.60	12.88	13.31	13.76	13.14	13.44	13.89	14.36	13.60	13.91	14.38	14.88						
	HI PR	252	271	286	299	283	304	321	335	322	346	365	381	366	394	416	434	412	443	468	488	455	490	517	539						
LO PR	103	109	119	127	108	115	126	134	113	120	131	139	118	126	137	146	124	132	144	153	128	136	149	159							
80	MBh	137.9	140.9	150.5	160.9	134.7	137.6	147.0	157.1	131.4	134.3	143.5	153.4	128.2	131.0	140.0	149.7	121.8	124.5	133.0	142.2	112.9	115.3	123.2	131.7						
	S/T	0.84	0.78	0.64	0.48	0.87	0.81	0.66	0.49	0.89	0.83	0.68	0.51	0.92	0.86	0.70	0.52	0.95	0.89	0.73	0.54	0.96	0.90	0.73	0.55						
	ΔT	26	25	22	18	27	26	22	18	27	26	22	18	27	26	23	18	27	26	22	18	25	24	21	17						
	kW	10.35	10.58	10.91	11.27	11.16	11.40	11.77	12.16	11.87	12.13	12.53	12.95	12.50	12.78	13.20	13.65	13.03	13.32	13.77	14.24	13.49	13.80	14.26	14.75						
	HI PR	249	268	283	296	280	301	318	332	318	343	362	377	363	390	412	430	408	439	464	483	451	485	512	534						
LO PR	102	108	118	126	107	114	125	133	111	119	129	138	117	125	136	145	123	131	143	152	127	135	147	157							
3500	MBh	127.2	130.0	138.9	148.5	124.3	127.0	135.7	145.0	121.3	124.0	132.5	141.6	118.4	120.9	129.2	138.1	112.4	114.9	122.8	131.2	104.2	106.4	113.7	121.6						
	S/T	0.81	0.76	0.62	0.46	0.84	0.78	0.64	0.48	0.86	0.80	0.65	0.49	0.88	0.83	0.67	0.50	0.92	0.86	0.70	0.52	0.93	0.87	0.71	0.53						
	ΔT	27	26	22	18	27	26	23	18	27	26	23	18	27	26	23	18	27	26	23	18	25	24	21	17						
	kW	10.10	10.32	10.65	10.99	10.88	11.12	11.48	11.86	11.57	11.83	12.22	12.62	12.18	12.45	12.87	13.30	12.70	12.98	13.42	13.87	13.15	13.44	13.89	14.37						
	HI PR	242	260	275	287	271	292	309	322	309	332	351	366	352	378	400	417	396	426	450	469	437	470	497	518						
LO PR	98	105	114	122	104	111	121	129	108	115	126	134	114	121	132	140	119	127	138	147	123	131	143	152							
4500	MBh	144.5	147.3	154.2	164.6	141.1	143.8	150.7	160.7	137.8	140.4	147.1	156.9	134.4	137.0	143.5	153.1	127.7	130.1	136.3	145.4	118.3	120.6	126.3	134.7						
	S/T	0.92	0.89	0.80	0.65	0.95	0.92	0.83	0.67	0.98	0.94	0.85	0.69	1.00	0.97	0.88	0.71	1.00	1.00	0.91	0.74	1.00	1.00	0.92	0.75						
	ΔT	27	27	25	22	27	27	26	22	27	27	26	22	27	27	26	22	26	27	25	22	24	25	24	21						
	kW	10.52	10.75	11.09	11.45	11.34	11.59	11.97	12.36	12.07	12.33	12.74	13.17	12.71	12.99	13.42	13.88	13.25	13.55	14.00	14.48	13.72	14.03	14.51	15.00						
	HI PR	254	274	289	302	286	307	324	338	325	349	369	385	370	398	420	438	416	448	473	493	460	495	522	545						
LO PR	104	110	120	128	109	116	127	135	114	121	132	141	119	127	139	148	125	133	145	155	129	138	150	160							
85	MBh	140.3	143.0	149.7	159.8	137.0	139.7	146.3	156.0	133.7	136.3	142.8	152.3	130.5	133.0	139.3	148.6	124.0	126.4	132.3	141.2	114.8	117.0	122.6	130.8						
	S/T	0.88	0.85	0.76	0.62	0.91	0.88	0.79	0.64	0.93	0.90	0.81	0.66	0.96	0.93	0.84	0.68	1.00	0.96	0.87	0.70	1.00	0.97	0.88	0.71						
	ΔT	28	28	26	23	29	28	27	23	29	28	27	23	29	28	27	23	28	28	26	23	26	26	25	21						
	kW	10.44	10.66	11.00	11.36	11.25	11.50	11.87	12.26	11.97	12.23	12.64	13.06	12.60	12.88	13.31	13.76	13.14	13.44	13.89	14.36	13.60	13.91	14.38	14.88						
	HI PR	252	271	286	299	283	304	321	335	322	346	365	381	366	394	416	434	412	443	468	488	455	490	517	539						
LO PR	103	109	119	127	108	115	126	134	113	120	131	139	118	126	137	146	124	132	144	153	128	136	149	159							
3500	MBh	129.5	132.0	138.2	147.5	126.5	128.9	135.0	144.0	123.4	125.8	131.8	140.6	120.4	122.8	128.6	137.2	114.4	116.6	122.1	130.3	106.0	108.0	113.1	120.7						
	S/T	0.85	0.82	0.74	0.60	0.88	0.85	0.76	0.62	0.90	0.87	0.78	0.63	0.93	0.89	0.81	0.65	0.96	0.93	0.84	0.68	0.97	0.94	0.84	0.69						
	ΔT	29	28	27	23	29	29	27	23	29	29	27	23	29	29	27	24	29	28	27	23	27	27	25	22						
	kW	10.18	10.40	10.73	11.08	10.97	11.21	11.57	11.96	11.67	11.93	12.32	12.73	12.28	12.56	12.97	13.41	12.81	13.09	13.53	13.99	13.26	13.56	14.01	14.49						
	HI PR	244	263	278	290	274	295	312	325	312	336	354	370	355	382	404	421	400	430	454	474	442	475	502	523						
LO PR	99	106	116	123	105	112	122	130	109	116	127	135	115	122	133	142	120	128	140	149	124	132	144	154							

IDB = Entering Indoor Dry Bulb Temperature  
 High & low pressures are measured at the liquid & suction service ports.  
 Shaded area reflects AHRI rating conditions  
 Design Superheat 8±3 °F @ the compressor suction access fitting connection.  
 Design Subcooling, 12±3 °F @ liquid access fitting connection AHRI 95 test conditions.

**DCH090**

	OUTDOOR AMBIENT TEMPERATURE																	
	65	60	55	50	47	45	40	35	30	25	20	17	15	10	5	0	-5	-10
MBh	113.1	107.1	100.8	94.2	90	87.2	81.0	74.7	56.1	51.8	47.7	45.0	43.3	38.9	34.5	30.1	25.7	21.0
T/R	34.9	33.1	31.1	29.1	27.8	26.9	25.0	23.1	17.3	16.0	14.7	13.9	13.4	12.0	10.6	9.3	7.9	6.5
kW	8.21	8.06	7.90	7.75	7.66	7.59	7.45	7.29	6.65	6.51	6.37	6.29	6.23	6.09	5.95	5.82	5.67	5.54
Amps	29.98	28.23	26.82	25.60	24.9	24.54	23.51	22.62	21.93	21.23	20.51	20.17	19.99	19.29	18.42	17.71	16.84	15.79
COP	4.0	3.9	3.7	3.6	3.4	3.4	3.2	3.0	2.5	2.3	2.2	2.1	2.0	1.9	1.7	1.5	1.3	1.1
HI PR	424	406	390	373	365	358	344	330	316	302	290	283	278	267	257	246	238	229
LO PR	134	124	117	107	101	97	89	80	72	64	56	52	51	43	37	31	27	21

**DCH102**

	OUTDOOR AMBIENT TEMPERATURE																	
	65	60	55	50	47	45	40	35	30	25	20	17	15	10	5	0	-5	-10
MBh	128.2	121.4	114.2	106.8	102	98.8	91.8	84.7	69.2	63.8	58.8	55.5	53.4	48.0	42.5	37.1	31.6	25.9
T/R	34.9	33.1	31.1	29.1	27.8	26.9	25.0	23.1	18.8	17.4	16.0	15.1	14.6	13.1	11.6	10.1	8.6	7.1
kW	9.34	9.17	8.99	8.82	8.72	8.64	8.48	8.30	7.83	7.66	7.50	7.41	7.34	7.17	7.01	6.85	6.68	6.52
Amps	37.57	35.17	33.25	31.57	30.6	30.13	28.71	27.51	26.55	25.60	24.63	24.16	23.91	22.95	21.77	20.79	19.61	18.17
COP	4.0	3.9	3.7	3.5	3.4	3.3	3.2	3.0	2.6	2.4	2.3	2.2	2.1	2.0	1.8	1.6	1.4	1.2
HI PR	419	401	386	369	360	354	340	326	312	298	287	280	275	264	254	244	235	227
LO PR	136	126	118	108	103	99	91	81	73	65	57	53	51	43	37	32	28	22

Above information is for nominal CFM and 70 degree indoor dry bulb. Instantaneous capacity listed.

kW = Total system power

High pressure is measured at the liquid line gauge port connection

Amps = Outdoor unit amps (comp.+fan)

Low pressure is measured at the compressor suction gauge port connection.

Design Super Heat 7°± 2 @ Suction Service Port 47 test condition



## DCH120

	OUTDOOR AMBIENT TEMPERATURE																	
	65	60	55	50	47	45	40	35	30	25	20	17	15	10	5	0	-5	-10
MBh	150.8	142.8	134.4	125.6	120	116.3	108.0	99.6	87.7	81.0	74.6	70.4	67.8	60.8	53.9	47.0	40.1	32.9
T/R	34.9	33.1	31.1	29.1	27.8	26.9	25.0	23.1	20.3	18.7	17.3	16.3	15.7	14.1	12.5	10.9	9.3	7.6
kW	10.70	10.50	10.31	10.11	10.0	9.92	9.73	9.54	8.65	8.47	8.30	8.20	8.13	7.95	7.78	7.61	7.44	7.27
Amps	41.27	38.87	36.93	35.26	34.3	33.81	32.39	31.18	30.22	29.27	28.29	27.82	27.57	26.61	25.42	24.44	23.26	21.81
COP	4.1	4.0	3.8	3.6	3.5	3.4	3.2	3.1	3.0	2.8	2.6	2.5	2.4	2.2	2.0	1.8	1.6	1.3
HI PR	439	421	405	387	378	371	356	342	328	313	301	293	288	277	266	256	246	238
LO PR	133	123	115	106	100	96	89	79	71	64	56	52	50	42	37	31	27	21

## DCH150

	OUTDOOR AMBIENT TEMPERATURE																	
	65	60	55	50	47	45	40	35	30	25	20	17	15	10	5	0	-5	-10
MBh	178.5	169.0	159.0	148.7	142	137.6	127.8	117.9	104.7	96.6	89.0	84.0	80.9	72.6	64.3	56.1	47.9	39.2
T/R	39.4	37.3	35.1	32.8	31.3	30.3	28.2	26.0	23.1	21.3	19.6	18.5	17.8	16.0	14.2	12.4	10.6	8.6
kW	13.89	13.64	13.39	13.14	13.0	12.89	12.65	12.40	12.36	12.10	11.85	11.70	11.60	11.34	11.09	10.85	10.59	10.34
COP	3.76	3.62	3.48	3.31	3.2	3.12	2.96	2.78	2.48	2.34	2.20	2.10	2.04	1.87	1.70	1.51	1.32	1.11
HI PR	471	452	434	415	405	398	382	367	351	336	322	315	309	297	286	274	264	255
LO PR	129	120	113	103	98	94	86	77	69	62	54	51	49	41	36	30	26	21

Above information is for nominal CFM and 70 degree indoor dry bulb. Instantaneous capacity listed.

kW = Total system power

High pressure is measured at the liquid line gauge port connection

Amps = Outdoor unit amps (comp.+fan)

Low pressure is measured at the compressor suction gauge port connection.

Design Super Heat 7°± 2 @ Suction Service Port 47 test condition

**TWO-SPEED STANDARD BELT DRIVE AT HIGH SPEED — DOWN SHOT**

ESP (IN W.C.)	TURNS OPEN																	
	0			1			2			3			4			5		
	CFM	RPM	BHP	CFM	RPM	BHP	CFM	RPM	BHP	CFM	RPM	BHP	CFM	RPM	BHP	CFM	RPM	BHP
0.1	---	---	---	---	---	---	---	---	---	---	---	---	3617	704	1.07	3293	653	0.84
0.3	---	---	---	---	---	---	---	---	---	3541	749	1.15	3179	704	0.88	2757	656	0.66
0.5	---	---	---	---	---	---	3447	798	1.23	3049	754	0.94	2606	710	0.71	---	---	---
0.7	---	---	---	3400	848	1.33	2950	798	1.01	2474	754	0.75	---	---	---	---	---	---
0.9	3303	890	1.41	2871	848	1.11	2408	804	0.82	---	---	---	---	---	---	---	---	---
1.1	2838	897	1.23	---	---	---	---	---	---	---	---	---	---	---	---	---	---	---

**TWO-SPEED HIGH-STATIC BELT DRIVE AT HIGH SPEED — DOWN SHOT**

ESP (IN W.C.)	TURNS OPEN																	
	0			1			2			3			4			5		
	CFM	RPM	BHP	CFM	RPM	BHP	CFM	RPM	BHP	CFM	RPM	BHP	CFM	RPM	BHP	CFM	RPM	BHP
0.9	---	---	---	---	---	---	---	---	---	---	---	---	---	---	---	3401	909	1.51
1.1	---	---	---	---	---	---	---	---	---	---	---	---	3428	965	1.71	2943	915	1.3
1.3	---	---	---	---	---	---	---	---	---	3471	1015	1.9	3012	971	1.5	2423	920	1.12
1.5	---	---	---	---	---	---	3722	1063	2.25	3041	1023	1.67	2503	976	1.31	---	---	---
1.7	---	---	---	---	---	---	3359	1075	2.04	2540	1031	1.5	---	---	---	---	---	---
1.9	---	---	---	3381	1119	2.22	2890	1080	1.78	---	---	---	---	---	---	---	---	---
2.1	---	---	---	3089	1129	2.04	---	---	---	---	---	---	---	---	---	---	---	---

**TWO-SPEED STANDARD BELT DRIVE AT HIGH SPEED — HORIZONTAL**

ESP (IN W.C.)	TURNS OPEN																	
	0			1			2			3			4			5		
	CFM	RPM	BHP	CFM	RPM	BHP	CFM	RPM	BHP	CFM	RPM	BHP	CFM	RPM	BHP	CFM	RPM	BHP
0.1	---	---	---	---	---	---	---	---	---	---	---	---	3625	701	1.08	3309	660	0.86
0.3	---	---	---	---	---	---	3815	797	1.44	3468	747	1.11	3177	703	0.88	2796	663	0.68
0.5	---	---	---	3780	841	1.52	3405	803	1.23	3053	753	0.94	2608	709	0.68	2225	665	0.53
0.7	3687	885	1.6	3327	847	1.29	2968	805	1.02	2423	758	0.73	---	---	---	---	---	---
0.9	3236	891	1.39	2850	852	1.1	2352	807	0.8	---	---	---	---	---	---	---	---	---
1.1	2713	896	1.17	---	---	---	---	---	---	---	---	---	---	---	---	---	---	---

**TWO-SPEED HIGH-STATIC BELT DRIVE AT HIGH SPEED — HORIZONTAL**

ESP (IN W.C.)	TURNS OPEN																	
	0			1			2			3			4			5		
	CFM	RPM	BHP	CFM	RPM	BHP	CFM	RPM	BHP	CFM	RPM	BHP	CFM	RPM	BHP	CFM	RPM	BHP
0.9	---	---	---	---	---	---	---	---	---	---	---	---	---	---	---	3447	902	1.54
1.1	---	---	---	---	---	---	---	---	---	---	---	---	3398	956	1.65	3006	908	1.31
1.3	---	---	---	---	---	---	---	---	---	3486	1008	1.87	2960	962	1.44	---	---	---
1.5	---	---	---	---	---	---	3514	1057	2.07	2949	1019	1.62	---	---	---	---	---	---
1.7	---	---	---	3388	1103	2.18	3036	1069	1.84	---	---	---	---	---	---	---	---	---
1.9	---	---	---	2959	1114	2.0	---	---	---	---	---	---	---	---	---	---	---	---
2.1	---	---	---	2527	1124	1.86	---	---	---	---	---	---	---	---	---	---	---	---

**NOTES**

- Assume dry coil with filter in place; CFM correction for wet coil = 3%
- Any adjustment made to the blower should not cause the motor to draw more than the motor rated RLA. Applications that exceed the above
- could require a larger motor. Minimum rated SCFM is 350 per ton.

**TWO-SPEED STANDARD BELT DRIVE AT HIGH SPEED — DOWN SHOT**

ESP (IN W.C.)	TURNS OPEN																	
	0			1			2			3			4			5		
	CFM	RPM	BHP	CFM	RPM	BHP	CFM	RPM	BHP	CFM	RPM	BHP	CFM	RPM	BHP	CFM	RPM	BHP
0.1	---	---	---	---	---	---	---	---	---	---	---	---	3467	701	1.04	3143	650	0.81
0.3	---	---	---	---	---	---	---	---	---	3391	746	1.12	3029	701	0.85	2607	653	0.63
0.5	---	---	---	---	---	---	3297	795	1.20	2899	751	0.91	2456	707	0.68	---	---	---
0.7	---	---	---	3250	845	1.30	2800	795	0.98	---	---	---	---	---	---	---	---	---
0.9	3153	887	1.38	2721	845	1.08	---	---	---	---	---	---	---	---	---	---	---	---
1.1	2688	894	1.20	---	---	---	---	---	---	---	---	---	---	---	---	---	---	---

**TWO-SPEED HIGH-STATIC BELT DRIVE AT HIGH SPEED — DOWN SHOT**

ESP (IN W.C.)	TURNS OPEN																	
	0			1			2			3			4			5		
	CFM	RPM	BHP	CFM	RPM	BHP	CFM	RPM	BHP	CFM	RPM	BHP	CFM	RPM	BHP	CFM	RPM	BHP
0.9	---	---	---	---	---	---	---	---	---	---	---	---	---	---	---	3251	906	1.48
1.1	---	---	---	---	---	---	---	---	---	---	---	---	3278	962	1.68	2793	912	1.27
1.3	---	---	---	---	---	---	---	---	---	3321	1012	1.87	2862	968	1.47	---	---	---
1.5	---	---	---	---	---	---	3572	1060	2.22	2891	1020	1.64	---	---	---	---	---	---
1.7	---	---	---	---	---	---	3209	1072	2.01	---	---	---	---	---	---	---	---	---
1.9	---	---	---	3231	1116	2.19	2740	1077	1.75	---	---	---	---	---	---	---	---	---
2.1	3256	1156	2.31	2939	1126	2.01	---	---	---	---	---	---	---	---	---	---	---	---

**TWO-SPEED STANDARD BELT DRIVE AT HIGH SPEED — HORIZONTAL**

ESP (IN W.C.)	TURNS OPEN																	
	0			1			2			3			4			5		
	CFM	RPM	BHP	CFM	RPM	BHP	CFM	RPM	BHP	CFM	RPM	BHP	CFM	RPM	BHP	CFM	RPM	BHP
0.1	---	---	---	---	---	---	---	---	---	---	---	---	3475	698	1.05	3159	657	0.83
0.3	---	---	---	---	---	---	3665	794	1.41	3318	744	1.08	3027	700	0.85	2646	660	0.65
0.5	---	---	---	3630	838	1.49	3255	800	1.2	2903	750	0.91	2458	706	0.65	---	---	---
0.7	3537	882	1.57	3177	844	1.26	2818	802	0.99	---	---	---	---	---	---	---	---	---
0.9	3086	888	1.36	2700	849	1.07	---	---	---	---	---	---	---	---	---	---	---	---
1.1	2563	893	1.14	---	---	---	---	---	---	---	---	---	---	---	---	---	---	---

**TWO-SPEED HIGH-STATIC BELT DRIVE AT HIGH SPEED — HORIZONTAL**

ESP (IN W.C.)	TURNS OPEN																	
	0			1			2			3			4			5		
	CFM	RPM	BHP	CFM	RPM	BHP	CFM	RPM	BHP	CFM	RPM	BHP	CFM	RPM	BHP	CFM	RPM	BHP
0.9	---	---	---	---	---	---	---	---	---	---	---	---	---	---	---	3297	899	1.51
1.1	---	---	---	---	---	---	---	---	---	---	---	---	3248	953	1.62	2856	905	1.28
1.3	---	---	---	---	---	---	---	---	---	3336	1005	1.84	2810	959	1.41	---	---	---
1.5	---	---	---	---	---	---	3364	1054	2.04	2799	1016	1.59	---	---	---	---	---	---
1.7	---	---	---	3238	1100	2.15	2886	1066	1.81	---	---	---	---	---	---	---	---	---
1.9	3188	1146	2.23	2809	1111	1.97	---	---	---	---	---	---	---	---	---	---	---	---

**NOTES**

- Assume dry coil with filter in place; CFM correction for wet coil = 3%
- Any adjustment made to the blower should not cause the motor to draw more than the motor rated RLA. Applications that exceed the above
- could require a larger motor. Minimum rated SCFM is 350 per ton.

**TWO-SPEED BELT DRIVE AT HIGH SPEED — DOWN SHOT**

ESP (IN W.C.)	TURNS OPEN																	
	0			1			2			3			4			5		
	CFM	RPM	BHP	CFM	RPM	BHP	CFM	RPM	BHP	CFM	RPM	BHP	CFM	RPM	BHP	CFM	RPM	BHP
0.2	---	---	---	---	---	---	---	---	---	---	---	---	4629	774	1.76	4269	733	1.42
0.4	---	---	---	---	---	---	---	---	4539	824	1.86	4198	781	1.53	3797	735	1.21	
0.6	---	---	---	---	---	---	4511	868	2.01	4103	829	1.63	3752	787	1.33	3312	745	1.03
0.8	---	---	---	4445	912	2.14	4144	873	1.81	3695	833	1.45	3180	790	1.07	---	---	---
1	4418	956	2.3	4073	917	1.92	3661	879	1.55	---	---	---	---	---	---	---	---	---
1.2	4064	967	2.09	3518	923	1.6	---	---	---	---	---	---	---	---	---	---	---	---
1.4	3555	972	1.77	---	---	---	---	---	---	---	---	---	---	---	---	---	---	---

**TWO-SPEED HIGH-STATIC BELT DRIVE AT HIGH SPEED — DOWN SHOT**

ESP (IN W.C.)	TURNS OPEN																	
	0			1			2			3			4			5		
	CFM	RPM	BHP	CFM	RPM	BHP	CFM	RPM	BHP	CFM	RPM	BHP	CFM	RPM	BHP	CFM	RPM	BHP
0.8	---	---	---	---	---	---	---	---	---	---	4288	2.63	4681	937	2.38	4206	891	1.91
1.0	---	---	---	---	---	---	---	4273	2.83	3858	2.37	4288	948	2.19	3721	897	1.63	
1.2	---	---	---	---	---	---	4296	3.07	3780	2.52	3327	2.08	3845	954	1.91	---	---	---
1.4	---	---	4551	3.81	4257	3.31	3706	2.65	3197	2.17	---	---	---	---	---	---	---	
1.6	---	---	4083	3.42	3842	2.99	3116	2.22	---	---	---	---	---	---	---	---	---	
1.8	4230	3.78	3809	3.18	3285	2.66	---	---	---	---	---	---	---	---	---	---	---	
2.0	3859	3.45	3322	2.87	---	---	---	---	---	---	---	---	---	---	---	---	---	
2.2	3445	3.11	---	---	---	---	---	---	---	---	---	---	---	---	---	---	---	

**TWO-SPEED BELT DRIVE AT HIGH SPEED — HORIZONTAL**

ESP (IN W.C.)	TURNS OPEN																	
	0			1			2			3			4			5		
	CFM	RPM	BHP	CFM	RPM	BHP	CFM	RPM	BHP	CFM	RPM	BHP	CFM	RPM	BHP	CFM	RPM	BHP
0.2	---	---	---	---	---	---	---	---	---	---	---	---	---	---	---	4707	724	1.62
0.4	---	---	---	---	---	---	---	---	---	---	---	---	4679	774	1.78	4235	730	1.4
0.6	---	---	---	---	---	---	---	---	---	4595	822	1.91	4223	780	1.55	3679	735	1.16
0.8	---	---	---	---	---	---	4468	862	1.96	4121	824	1.64	3596	785	1.26	---	---	---
1	---	---	---	4349	907	2.06	3990	868	1.72	3463	829	1.31	---	---	---	---	---	---
1.2	4486	962	2.35	3923	918	1.84	3267	879	1.33	---	---	---	---	---	---	---	---	
1.4	3990	967	2.03	---	---	---	---	---	---	---	---	---	---	---	---	---	---	

**TWO-SPEED HIGH-STATIC BELT DRIVE AT HIGH SPEED — HORIZONTAL**

ESP (IN W.C.)	TURNS OPEN																	
	0			1			2			3			4			5		
	CFM	RPM	BHP	CFM	RPM	BHP	CFM	RPM	BHP	CFM	RPM	BHP	CFM	RPM	BHP	CFM	RPM	BHP
0.8	---	---	---	---	---	---	---	---	---	---	4388	2.74	4681	937	2.38	4206	891	1.91
1.0	---	---	---	---	---	---	---	4374	2.95	4039	2.52	4288	948	2.19	3721	897	1.63	
1.2	---	---	---	---	---	---	4406	3.22	3975	2.67	3451	2.15	3845	954	1.91	---	---	---
1.4	---	---	---	---	4320	3.36	3965	2.90	3505	2.38	---	---	---	---	---	---	---	
1.6	---	---	4378	3.61	3493	2.72	3381	2.52	3015	2.06	---	---	---	---	---	---	---	
1.8	4440	3.77	3729	3.07	---	---	---	---	---	---	---	---	---	---	---	---	---	
2.0	4015	3.38	3080	2.52	---	---	---	---	---	---	---	---	---	---	---	---	---	
2.2	3522	2.96	---	---	---	---	---	---	---	---	---	---	---	---	---	---	---	

**TWO-SPEED BELT DRIVE AT HIGH SPEED — DOWN SHOT**

ESP (IN W.C.)	TURNS OPEN											
	0		1		2		3		4		5	
	CFM	BHP	CFM	BHP	CFM	BHP	CFM	BHP	CFM	BHP	CFM	BHP
0.2	---	---	5605	2.74	5271	2.32	4915	1.95	4587	1.63	4185	1.32
0.4	5548	2.96	5202	2.51	4792	2.09	4439	1.73	4073	1.43	3606	1.14
0.6	5136	2.71	4533	2.14	4315	1.84	3860	1.51	---	---	---	---
0.8	4692	2.51	3931	1.86	3742	1.60	---	---	---	---	---	---
1.0	4166	2.17	---	---	---	---	---	---	---	---	---	---

**TWO-SPEED HIGH-STATIC BELT DRIVE AT HIGH SPEED — DOWN SHOT**

ESP (IN W.C.)	TURNS OPEN											
	0		1		2		3		4		5	
	CFM	BHP	CFM	BHP	CFM	BHP	CFM	BHP	CFM	BHP	CFM	BHP
0.8	---	---	---	---	---	---	5332	3.64	4910	3.09	4479	2.55
1.0	---	---	5660	4.52	5271	3.87	4827	3.28	4361	2.74	3932	2.22
1.2	5582	5.05	5187	4.12	4802	3.52	4332	2.93	3822	2.38	---	---
1.4	5174	4.65	4707	3.69	4260	3.09	3683	2.48	---	---	---	---
1.6	4695	4.23	4208	3.28	3586	2.61	---	---	---	---	---	---
1.8	4187	3.79	3680	2.86	---	---	---	---	---	---	---	---
2.0	3602	3.30	---	---	---	---	---	---	---	---	---	---

**TWO-SPEED BELT DRIVE AT HIGH SPEED — HORIZONTAL**

ESP (IN W.C.)	TURNS OPEN											
	0		1		2		3		4		5	
	CFM	BHP	CFM	BHP	CFM	BHP	CFM	BHP	CFM	BHP	CFM	BHP
0.2	5230	3.15	4998	2.72	4592	2.24	4474	1.99	4160	1.67	3825	1.40
0.4	4933	2.92	4619	2.47	4244	2.05	4063	1.79	3722	1.48	---	---
0.6	4602	2.69	4220	2.22	3840	1.84	3652	1.58	---	---	---	---
0.8	4265	2.46	3797	1.98	---	---	---	---	---	---	---	---
1.0	3883	2.21	---	---	---	---	---	---	---	---	---	---

**TWO-SPEED HIGH-STATIC BELT DRIVE AT HIGH SPEED — HORIZONTAL**

ESP (IN W.C.)	TURNS OPEN											
	0		1		2		3		4		5	
	CFM	BHP	CFM	BHP	CFM	BHP	CFM	BHP	CFM	BHP	CFM	BHP
0.8	5592	4.84	5460	4.22	5178	3.74	4851	3.32	4481	2.84	4115	2.38
1.0	5436	4.52	5120	3.92	4770	3.41	4445	3.02	4087	2.57	3673	2.13
1.2	5125	4.22	4780	3.62	4354	3.08	4036	2.73	3670	2.88	---	---
1.4	4795	3.91	4421	3.31	3990	2.81	3602	2.42	---	---	---	---
1.6	4410	3.57	4036	3.00	3652	2.57	---	---	---	---	---	---
1.8	3996	3.22	3593	2.66	---	---	---	---	---	---	---	---
2.0	3760	2.96	---	---	---	---	---	---	---	---	---	---

**NOTES**

- Assume dry coil with filter in place; CFM correction for wet coil = 3%
- Any adjustment made to the blower should not cause the motor to draw more than the motor rated RLA. Application that exceed the above could require a larger motor. Minimum rated SCFM is 350 per ton.

**AIRFLOW PRESSURE DROP OF DOWNFLOW ECONOMIZER FOR 7.5 TO 12.5 TON ROOFTOP UNITS (100% RETURN AIR)**

SCFM	2000	2500	3000	3500	4000	4500	5000	5500
in. WG	0.02	0.04	0.06	0.09	0.13	0.18	0.23	0.29

HIGH EFFICIENCY MERV 13 AIR FILTER OPTION

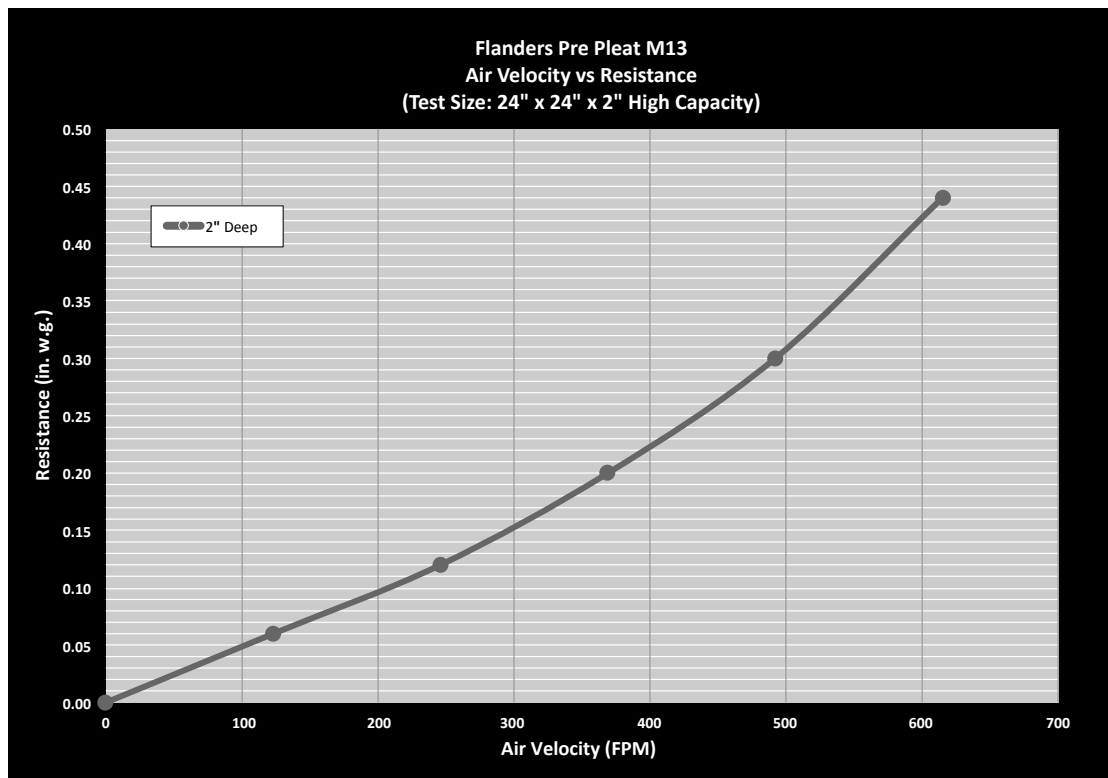

TONNAGE:	FILTER NOMINAL SIZE:	PART NUMBER:	ORDER QTY:
7.5	16 x 20 x 2	0160L00205	4
7.5(HP), 8.5, 10	16 X 24 X 2	0160L00206	4
12.5	20 x 20 x 2	0160L00201	4
	14 x 20 x 2	0160L00204	2

CRANKCASE HEATER SELECTION TABLE

ZP/ZPS...	COMPRESSOR DIAMETER	COMPRESSOR VOLTAGE			CRANKCASE HEATER WATTS
		230V	460V	575V	
16-31	5.5"	0163R00002S	0163R00031S	0163R00032S	40
39-83	6.58/7.3"	0130L00017S	0130L00018S	0130L00019S	70
103-137	9.14"	0130L00020S	0130L00021S	0130L00022S	90

DC* TONNAGE	COMPRESSOR VOLTAGE			CRANKCASE HEATER WATTS
	230V	460V	575V	
7.5 Ton-12.5 Ton	0130L00017S	0130L00018S	0130L00019S	70

MODEL NUMBER	ELECTRICAL RATING	COMPRESSOR CIRCUIT 1		COMPRESSOR CIRCUIT 2		OUTDOOR FAN MOTOR			INDOOR FAN MOTOR			OPTIONAL ELECTRIC HEAT			OPTIONAL POWERED CONVENIENCE OUTLET	UNIT POWER SUPPLY	
		RLA	LRA	RLA	LRA	QTY	HP	FLA	TYPE	HP	FLA	MODEL	KW*	FLA	FLA	MCA	MOP
DCH090XXX3W	208/230-3-60	13.1	83.1	13.1	83.1	2	0.25	1.4	2-speed High Static Belt Drive	2.00	6.0	-	-	-	-	38.4 / 38.4	50 / 50
												EHK3-16	11.3 / 15.0	31.3 / 36.1	-	77.5 / 83.5	80 / 90
												EHK3-30	22.5 / 29.9	62.3 / 71.9	-	116 / 128	125 / 150
												EHK3-45	33.7 / 44.9	93.6 / 108	-	155 / 173	175 / 175
												-	-	-	7.2 / 6.5	45.6 / 44.9	50 / 50
												EHK3-16	11.3 / 15.0	31.3 / 36.1	7.2 / 6.5	84.7 / 90.0	90 / 90
												EHK3-30	22.5 / 29.9	62.3 / 71.9	7.2 / 6.5	123 / 135	125 / 150
EHK3-45	33.7 / 44.9	93.6 / 108	7.2 / 6.5	163 / 180	175 / 200												
DCH090XXX3V	208/230-3-60	13.1	83.1	13.1	83.1	2	0.25	1.4	2-speed Belt Drive	2.00	6.0	-	-	-	-	38.4 / 38.4	50 / 50
												EHK3-16	11.3 / 15.0	31.3 / 36.1	-	77.5 / 83.5	80 / 90
												EHK3-30	22.5 / 29.9	62.3 / 71.9	-	116 / 128	125 / 150
												EHK3-45	33.7 / 44.9	93.6 / 108	-	155 / 173	175 / 175
												-	-	-	7.2 / 6.5	45.6 / 44.9	50 / 50
												EHK3-16	11.3 / 15.0	31.3 / 36.1	7.2 / 6.5	84.7 / 90.0	90 / 90
												EHK3-30	22.5 / 29.9	62.3 / 71.9	7.2 / 6.5	123 / 135	125 / 150
EHK3-45	33.7 / 44.9	93.6 / 108	7.2 / 6.5	163 / 180	175 / 200												
DCH090XXX4W	460-3-60	6.1	41.0	6.1	41.0	2	0.25	0.7	2-speed High Static Belt Drive	2.00	2.9	-	-	-	-	18.0	20
												EHK4-16	15.0	18.0	-	40.6	45
												EHK4-30	29.9	36.0	-	63.0	70
												EHK4-45	44.9	54.0	-	85.5	90
												-	-	-	3.3	21.3	25
												EHK4-16	15.0	18.0	3.3	43.9	45
												EHK4-30	29.9	36.0	3.3	66.3	70
EHK4-45	44.9	54.0	3.3	88.8	90												
DCH090XXX4V	460-3-60	6.1	41.0	6.1	41.0	2	0.25	0.7	2-speed Belt Drive	2.00	2.9	-	-	-	-	18.0	20
												EHK4-16	15.0	18.0	-	40.6	45
												EHK4-30	29.9	36.0	-	63.0	70
												EHK4-45	44.9	54.0	-	85.5	90
												-	-	-	3.3	21.3	25
												EHK4-16	15.0	18.0	3.3	43.9	45
												EHK4-30	29.9	36.0	3.3	66.3	70
EHK4-45	44.9	54.0	3.3	88.8	90												
DCH090XXX7W	575-3-60	4.4	33.0	4.4	33.0	2	0.25	0.6	2-speed High Static Belt Drive	2.00	2.4	-	-	-	-	13.4	15
												EHK7-16	15.0	15.1	-	32.2	35
												EHK7-30	29.9	30.0	-	50.9	60
												EHK7-45	44.9	45.1	-	69.8	70
												-	-	-	2.6	16.0	20
												EHK7-16	15.0	15.1	2.6	34.8	35
												EHK7-30	29.9	30.0	2.6	53.5	60
EHK7-45	44.9	45.1	2.6	72.4	80												
DCH090XXX7V	575-3-60	4.4	33.0	4.4	33.0	2	0.25	0.6	2-speed Belt Drive	2.00	2.4	-	-	-	-	13.4	15
												EHK7-16	15.0	15.1	-	32.2	35
												EHK7-30	29.9	30.0	-	50.9	60
												EHK7-45	44.9	45.1	-	69.8	70
												-	-	-	2.6	16.0	20
												EHK7-16	15.0	15.1	2.6	34.8	35
												EHK7-30	29.9	30.0	2.6	53.5	60
EHK7-45	44.9	45.1	2.6	72.4	80												

\* Electric Heater kW rating: Rated at 240v for 208-230v units; 480v for 460v units

MODEL NUMBER	ELECTRICAL RATING	COMPRESSOR CIRCUIT 1		COMPRESSOR CIRCUIT 2		OUTDOOR FAN MOTOR			INDOOR FAN MOTOR			OPTIONAL ELECTRIC HEAT			OPTIONAL POWERED CONVENIENCE OUTLET	UNIT POWER SUPPLY	
		RLA	LRA	RLA	LRA	QTY	HP	FLA	TYPE	HP	FLA	MODEL	KW*	FLA	FLA	MCA	MOP
DCH102XXX3W	208/230-3-60	14.5	98.0	14.5	98.0	2	0.33	2.3	2-speed High Static Belt Drive	2.00	6.0	-	-	-	43.2 / 43.2	50 / 50	
												EHK3-16	11.3 / 15.0	31.3 / 36.1	-	82.3 / 88.3	90 / 90
												EHK3-30	22.5 / 29.9	62.3 / 71.9	-	121 / 133	125 / 150
												EHK3-45	33.7 / 44.9	93.6 / 108	-	160 / 178	175 / 200
												-	-	-	7.2 / 6.5	50.4 / 49.7	60 / 60
												EHK3-16	11.3 / 15.0	31.3 / 36.1	7.2 / 6.5	89.5 / 94.8	90 / 100
												EHK3-30	22.5 / 29.9	62.3 / 71.9	7.2 / 6.5	128 / 140	150 / 150
EHK3-45	33.7 / 44.9	93.6 / 108	7.2 / 6.5	167 / 185	175 / 200												
DCH102XXX3V	208/230-3-60	14.5	98.0	14.5	98.0	2	0.33	2.3	2-speed Belt Drive	2.00	6.0	-	-	-	43.2 / 43.2	50 / 50	
												EHK3-16	11.3 / 15.0	31.3 / 36.1	-	82.3 / 88.3	90 / 90
												EHK3-30	22.5 / 29.9	62.3 / 71.9	-	121 / 133	125 / 150
												EHK3-45	33.7 / 44.9	93.6 / 108	-	160 / 178	175 / 200
												-	-	-	7.2 / 6.5	50.4 / 49.7	60 / 60
												EHK3-16	11.3 / 15.0	31.3 / 36.1	7.2 / 6.5	89.5 / 94.8	90 / 100
												EHK3-30	22.5 / 29.9	62.3 / 71.9	7.2 / 6.5	128 / 140	150 / 150
EHK3-45	33.7 / 44.9	93.6 / 108	7.2 / 6.5	167 / 185	175 / 200												
DCH102XXX4W	460-3-60	6.3	55.0	6.3	55.0	2	0.33	1.1	2-speed High Static Belt Drive	2.00	2.9	-	-	-	19.4	25	
												EHK4-16	15.0	18.0	-	41.9	45
												EHK4-30	29.9	36.0	-	64.3	70
												EHK4-45	44.9	54.0	-	86.9	90
												-	-	-	3.3	22.7	25
												EHK4-16	15.0	18.0	3.3	45.2	50
												EHK4-30	29.9	36.0	3.3	67.6	70
EHK4-45	44.9	54.0	3.3	90.2	100												
DCH102XXX4V	460-3-60	6.3	55.0	6.3	55.0	2	0.33	1.1	2-speed Belt Drive	2.00	2.9	-	-	-	19.4	25	
												EHK4-16	15.0	18.0	-	41.9	45
												EHK4-30	29.9	36.0	-	64.3	70
												EHK4-45	44.9	54.0	-	86.9	90
												-	-	-	3.3	22.7	25
												EHK4-16	15.0	18.0	3.3	45.2	50
												EHK4-30	29.9	36.0	3.3	67.6	70
EHK4-45	44.9	54.0	3.3	90.2	100												
DCH102XXX7W	575-3-60	6.0	41.0	6.0	41.0	2	0.33	0.9	2-speed High Static Belt Drive	2.00	2.4	-	-	-	17.8	20	
												EHK7-16	15.0	15.1	-	36.6	40
												EHK7-30	29.9	30.0	-	55.3	60
												EHK7-45	44.9	45.1	-	74.1	80
												-	-	-	2.6	20.4	25
												EHK7-16	15.0	15.1	2.6	39.2	40
												EHK7-30	29.9	30.0	2.6	57.9	60
EHK7-45	44.9	45.1	2.6	76.7	80												
DCH102XXX7V	575-3-60	6.0	41.0	6.0	41.0	2	0.33	0.9	2-speed Belt Drive	2.00	2.4	-	-	-	17.8	20	
												EHK7-16	15.0	15.1	-	36.6	40
												EHK7-30	29.9	30.0	-	55.3	60
												EHK7-45	44.9	45.1	-	74.1	80
												-	-	-	2.6	20.4	25
												EHK7-16	15.0	15.1	2.6	39.2	40
												EHK7-30	29.9	30.0	2.6	57.9	60
EHK7-45	44.9	45.1	2.6	76.7	80												

\* Electric Heater kW rating: Rated at 240v for 208-230v units; 480v for 460v units



MODEL NUMBER	ELECTRICAL RATING	COMPRESSOR CIRCUIT 1		COMPRESSOR CIRCUIT 2		OUTDOOR FAN MOTOR			INDOOR FAN MOTOR			OPTIONAL ELECTRIC HEAT			OPTIONAL POWERED CONVENIENCE OUTLET	UNIT POWER SUPPLY	
		RLA	LRA	RLA	LRA	QTY	HP	FLA	TYPE	HP	FLA	MODEL	KW*	FLA	FLA	MCA	MOP
DCH120XXX3W	208/230-3-60	16.0	110.0	16.0	110.0	2	0.33	2.0	2-speed High Static Belt Drive	5.00	14.0	-	-	-	53.9 / 53.9	60 / 60	
												EHK3-16	11.3 / 15.0	31.3 / 36.1	-	93.0 / 99.0	100 / 100
												EHK3-30	22.5 / 29.9	62.3 / 71.9	-	132 / 144	150 / 150
												EHK3-45	33.7 / 44.9	93.6 / 108	-	171 / 189	175 / 200
												-	-	-	7.2 / 6.5	61.1 / 60.4	70 / 70
												EHK3-16	11.3 / 15.0	31.3 / 36.1	7.2 / 6.5	100 / 106	100 / 110
												EHK3-30	22.5 / 29.9	62.3 / 71.9	7.2 / 6.5	139 / 150	150 / 150
												EHK3-45	33.7 / 44.9	93.6 / 108	7.2 / 6.5	178 / 195	200 / 200
DCH120XXX3V	208/230-3-60	16.0	110.0	16.0	110.0	2	0.33	2.0	2-speed Belt Drive	2.00	6.4	-	-	-	46.3 / 46.3	60 / 60	
												EHK3-16	11.3 / 15.0	31.3 / 36.1	-	85.4 / 91.4	90 / 100
												EHK3-30	22.5 / 29.9	62.3 / 71.9	-	124 / 136	125 / 150
												EHK3-45	33.7 / 44.9	93.6 / 108	-	163 / 181	175 / 200
												-	-	-	7.2 / 6.5	53.5 / 52.8	60 / 60
												EHK3-16	11.3 / 15.0	31.3 / 36.1	7.2 / 6.5	92.6 / 97.9	100 / 100
												EHK3-30	22.5 / 29.9	62.3 / 71.9	7.2 / 6.5	131 / 143	150 / 150
												EHK3-45	33.7 / 44.9	93.6 / 108	7.2 / 6.5	171 / 188	175 / 200
DCH120XXX4W	460-3-60	7.8	52.0	7.8	52.0	2	0.33	0.9	2-speed High Static Belt Drive	5.00	6.6	-	-	-	25.8	30	
												EHK4-16	15.0	18.0	-	48.3	50
												EHK4-30	29.9	36.0	-	70.7	80
												EHK4-45	44.9	54.0	-	93.3	100
												-	-	-	3.3	29.1	35
												EHK4-16	15.0	18.0	3.3	51.6	60
												EHK4-30	29.9	36.0	3.3	74.0	80
												EHK4-45	44.9	54.0	3.3	96.6	100
DCH120XXX4V	460-3-60	7.8	52.0	7.8	52.0	2	0.33	0.9	2-speed Belt Drive	2.00	3.0	-	-	-	22.2	25	
												EHK4-16	15.0	18.0	-	44.7	45
												EHK4-30	29.9	36.0	-	67.1	70
												EHK4-45	44.9	54.0	-	89.7	90
												-	-	-	3.3	25.5	30
												EHK4-16	15.0	18.0	3.3	48.0	50
												EHK4-30	29.9	36.0	3.3	70.4	80
												EHK4-45	44.9	54.0	3.3	93.0	100
DCH120XXX7W	575-3-60	5.7	38.9	5.7	38.9	2	0.33	0.7	2-speed High Static Belt Drive	5.00	5.2	-	-	-	19.4	25	
												EHK7-16	15.0	15.1	-	38.3	40
												EHK7-30	29.9	30.0	-	57.0	60
												EHK7-45	44.9	45.1	-	75.8	80
												-	-	-	2.6	22.0	25
												EHK7-16	15.0	15.1	2.6	40.9	45
												EHK7-30	29.9	30.0	2.6	59.6	60
												EHK7-45	44.9	45.1	2.6	78.4	80
DCH120XXX7V	575-3-60	5.7	38.9	5.7	38.9	2	0.33	0.7	2-speed Belt Drive	2.00	2.4	-	-	-	16.6	20	
												EHK7-16	15.0	15.1	-	35.5	40
												EHK7-30	29.9	30.0	-	54.2	60
												EHK7-45	44.9	45.1	-	73.0	80
												-	-	-	2.6	19.2	20
												EHK7-16	15.0	15.1	2.6	38.1	40
												EHK7-30	29.9	30.0	2.6	56.8	60
												EHK7-45	44.9	45.1	2.6	75.6	80

\* Electric Heater kW rating: Rated at 240v for 208-230v units; 480v for 460v units

MODEL NUMBER	ELECTRICAL RATING	COMPRESSOR CIRCUIT 1		COMPRESSOR CIRCUIT 2		OUTDOOR FAN MOTOR			INDOOR FAN MOTOR			OPTIONAL ELECTRIC HEAT			OPTIONAL POWERED CONVENIENCE OUTLET	UNIT POWER SUPPLY	
		RLA	LRA	RLA	LRA	QTY	HP	FLA	TYPE	HP	FLA	MODEL	KW*	FLA	FLA	MCA	MOP
DCH150XXX3W	208/230-3-60	22.4	149.0	22.4	149.0	2	0.33	2.0	2-speed High Static Belt Drive	5.00	14.0	-	-	-	-	68.5 / 68.5	90 / 90
												EHK3-16	11.3 / 15.0	31.3 / 36.1	-	108 / 114	110 / 125
												EHK3-30	22.5 / 29.9	62.3 / 71.9	-	146 / 158	150 / 175
												EHK3-45	33.7 / 44.9	93.6 / 108	-	185 / 203	200 / 225
												-	-	-	7.2 / 6.5	75.7 / 75.0	90 / 90
												EHK3-16	11.3 / 15.0	31.3 / 36.1	7.2 / 6.5	115 / 120	125 / 125
												EHK3-30	22.5 / 29.9	62.3 / 71.9	7.2 / 6.5	154 / 165	175 / 175
EHK3-45	33.7 / 44.9	93.6 / 108	7.2 / 6.5	193 / 210	200 / 225												
DCH150XXX3V	208/230-3-60	22.4	149.0	22.4	149.0	2	0.33	2.0	2-speed Belt Drive	3.00	9.1	-	-	-	-	63.6 / 63.6	80 / 80
												EHK3-16	11.3 / 15.0	31.3 / 36.1	-	103 / 109	110 / 110
												EHK3-30	22.5 / 29.9	62.3 / 71.9	-	142 / 153	150 / 175
												EHK3-45	33.7 / 44.9	93.6 / 108	-	181 / 199	200 / 200
												-	-	-	7.2 / 6.5	70.8 / 70.1	90 / 90
												EHK3-16	11.3 / 15.0	31.3 / 36.1	7.2 / 6.5	110 / 115	110 / 125
												EHK3-30	22.5 / 29.9	62.3 / 71.9	7.2 / 6.5	149 / 160	150 / 175
EHK3-45	33.7 / 44.9	93.6 / 108	7.2 / 6.5	188 / 205	200 / 225												
DCH150XXX4W	460-3-60	10.6	75.0	10.6	75.0	2	0.33	0.9	2-speed High Static Belt Drive	5.00	6.6	-	-	-	-	32.1	40
												EHK4-16	15.0	18.0	-	54.7	60
												EHK4-30	29.9	36.0	-	77.1	80
												EHK4-45	44.9	54.0	-	99.6	100
												-	-	-	3.3	35.4	45
												EHK4-16	15.0	18.0	3.3	58.0	60
												EHK4-30	29.9	36.0	3.3	80.4	90
EHK4-45	44.9	54.0	3.3	103	110												
DCH150XXX4V	460-3-60	10.6	75.0	10.6	75.0	2	0.33	0.9	2-speed Belt Drive	3.00	4.3	-	-	-	-	29.8	40
												EHK4-16	15.0	18.0	-	52.4	60
												EHK4-30	29.9	36.0	-	74.8	80
												EHK4-45	44.9	54.0	-	97.3	100
												-	-	-	3.3	33.1	40
												EHK4-16	15.0	18.0	3.3	55.7	60
												EHK4-30	29.9	36.0	3.3	78.1	80
EHK4-45	44.9	54.0	3.3	101	110												
DCH150XXX7W	575-3-60	7.7	54.0	7.7	54.0	2	0.33	0.7	2-speed High Static Belt Drive	5.00	5.2	-	-	-	-	23.9	30
												EHK7-16	15.0	15.1	-	42.7	45
												EHK7-30	29.9	30.0	-	61.4	70
												EHK7-45	44.9	45.1	-	80.3	90
												-	-	-	2.6	26.5	30
												EHK7-16	15.0	15.1	2.6	45.3	50
												EHK7-30	29.9	30.0	2.6	64.0	70
EHK7-45	44.9	45.1	2.6	82.9	90												
DCH150XXX7V	575-3-60	7.7	54.0	7.7	54.0	2	0.33	0.7	2-speed Belt Drive	3.00	3.5	-	-	-	-	22.2	25
												EHK7-16	15.0	15.1	-	41.0	45
												EHK7-30	29.9	30.0	-	59.7	60
												EHK7-45	44.9	45.1	-	78.6	80
												-	-	-	2.6	24.8	30
												EHK7-16	15.0	15.1	2.6	43.6	45
												EHK7-30	29.9	30.0	2.6	62.3	70
EHK7-45	44.9	45.1	2.6	81.2	90												

\* Electric Heater kW rating: Rated at 240v for 208-230v units; 480v for 460v units

MODEL AND HEAT KIT USAGE	RECOMMENDED AIRFLOW RANGE
DCH090***3V***	
EHK3-16	3000-3375 CFM
EHK3-30	3000-3375 CFM
EHK3-45	3000-3375 CFM

MODEL AND HEAT KIT USAGE	RECOMMENDED AIRFLOW RANGE
DCH090***4V***	
EHK4-16	3000-3375 CFM
EHK4-30	3000-3375 CFM
EHK4-45	3000-3375 CFM

MODEL AND HEAT KIT USAGE	RECOMMENDED AIRFLOW RANGE
DCH090***7V***	
EHK7-16	3000-3375 CFM
EHK7-30	3000-3375 CFM
EHK7-45	3000-3375 CFM

kW CORRECTION FACTOR

kW CORRECTION FACTOR FOR 208/230V UNITS					
SUPPLY VOLTAGE	240	230	220	210	208
CORRECTION FACTOR	1	0.92	0.84	0.77	0.75

kW CORRECTION FACTOR FOR 480V UNITS			
SUPPLY VOLTAGE	460	440	430
CORRECTION FACTOR	0.92	0.84	0.8

For other voltage, use  $\text{voltage}^2 / 480^2$

kW CORRECTION FACTOR FOR 575V UNITS			
SUPPLY VOLTAGE	560	550	540
CORRECTION FACTOR	0.95	0.91	0.88

Multiply rated kW by correction factor to get actual kW.

MODEL AND HEAT KIT USAGE	RECOMMENDED AIRFLOW RANGE (DOWNSHOT)	RECOMMENDED AIRFLOW RANGE (HORIZONTAL)
<b>DCH102***3V***</b>		
EHK3-16	3400 - 3825 CFM	3400 - 3825 CFM
EHK3-30	3400 - 3825 CFM	3400 - 3825 CFM
EHK3-45	3400 - 3825 CFM	3400 - 3825 CFM

MODEL AND HEAT KIT USAGE	RECOMMENDED AIRFLOW RANGE (DOWNSHOT)	RECOMMENDED AIRFLOW RANGE (HORIZONTAL)
<b>DCH102***4V***</b>		
EHK4-16	3400 - 3825 CFM	3400 - 3825 CFM
EHK4-30	3400 - 3825 CFM	3400 - 3825 CFM
EHK4-45	3400 - 3825 CFM	3400 - 3825 CFM

MODEL AND HEAT KIT USAGE	RECOMMENDED AIRFLOW RANGE (DOWNSHOT)	RECOMMENDED AIRFLOW RANGE (HORIZONTAL)
<b>DCH102***7V***</b>		
EHK7-16	3400 - 3825 CFM	3400 - 3825 CFM
EHK7-30	3400 - 3825 CFM	3400 - 3825 CFM
EHK7-45	3400 - 3825 CFM	3400 - 3825 CFM

^ - EHK Heater Kits above require a three-phase power supply

KW CORRECTION FACTOR

kW CORRECTION FACTOR FOR 208/230V UNITS					
SUPPLY VOLTAGE	240	230	220	210	208
CORRECTION FACTOR	1	0.92	0.84	0.77	0.75

kW CORRECTION FACTOR FOR 480V UNITS			
SUPPLY VOLTAGE	460	440	430
CORRECTION FACTOR	0.92	0.84	0.8

For other voltage, use  $\text{voltage}^2 / 480^2$

kW CORRECTION FACTOR FOR 575V UNITS			
SUPPLY VOLTAGE	560	550	540
CORRECTION FACTOR	0.95	0.91	0.88

Multiply rated kW by correction factor to get actual kW.

MODEL AND HEAT KIT USAGE	RECOMMENDED AIRFLOW RANGE
DCH120***3V***	
EHK3-16	3500 - 4500 CFM
EHK3-30	3500 - 4500 CFM
EHK3-45	4000 - 4500 CFM

MODEL AND HEAT KIT USAGE	RECOMMENDED AIRFLOW RANGE
DCH120***4V***	
EHK4-16	3500 - 4500 CFM
EHK4-30	3500 - 4500 CFM
EHK4-45	4000 - 4500 CFM

MODEL AND HEAT KIT USAGE	RECOMMENDED AIRFLOW RANGE
DCH0120***7V***	
EHK7-16	3500 - 4500 CFM
EHK7-30	3500 - 4500 CFM
EHK7-45	4000 - 4500 CFM

## kW CORRECTION FACTOR

kW CORRECTION FACTOR FOR 208/230V UNITS					
SUPPLY VOLTAGE	240	230	220	210	208
CORRECTION FACTOR	1	0.92	0.84	0.77	0.75

kW CORRECTION FACTOR FOR 480V UNITS			
SUPPLY VOLTAGE	460	440	430
CORRECTION FACTOR	0.92	0.84	0.8

For other voltage, use  $\text{voltage}^2 / 480^2$

kW CORRECTION FACTOR FOR 575V UNITS			
SUPPLY VOLTAGE	560	550	540
CORRECTION FACTOR	0.95	0.91	0.88

Multiply rated kW by correction factor to get actual kW.

MODEL AND HEAT KIT USAGE	RECOMMENDED AIRFLOW RANGE
<b>DCH150***3V***</b>	
EHK3-16	4000 - 5600
EHK3-30	4300 - 5600
EHK3-45	4500 - 5600

MODEL AND HEAT KIT USAGE	RECOMMENDED AIRFLOW RANGE
<b>DCH150***4V***</b>	
EHK4-16	4000 - 5600
EHK4-30	4300 - 5600
EHK4-45	4500 - 5600

MODEL AND HEAT KIT USAGE	RECOMMENDED AIRFLOW RANGE
<b>DCH150***7V***</b>	
EHK7-16	4000 - 5600
EHK7-30	4300 - 5600
EHK7-45	4500 - 5600

kW CORRECTION FACTOR

kW CORRECTION FACTOR FOR 208/230V UNITS					
SUPPLY VOLTAGE	240	230	220	210	208
CORRECTION FACTOR	1	0.92	0.84	0.77	0.75

kW CORRECTION FACTOR FOR 480V UNITS			
SUPPLY VOLTAGE	460	440	430
CORRECTION FACTOR	0.92	0.84	0.8

For other voltage, use  $\text{voltage}^2 / 480^2$

kW CORRECTION FACTOR FOR 575V UNITS			
SUPPLY VOLTAGE	560	550	540
CORRECTION FACTOR	0.95	0.91	0.88

Multiply rated kW by correction factor to get actual kW.

MODEL TONNAGE	"A"	"B"
7.5 TON COMMERCIAL GAS, HT PUMP, AIR CONDITIONER	53.339	20.055
8.5 TON COMMERCIAL GAS, HT PUMP, AIR CONDITIONER	53.339	20.055
10 TON COMMERCIAL GAS, HT PUMP, AIR CONDITIONER	53.339	20.055
12.5 TON COMMERCIAL GAS, HT PUMP, AIR CONDITIONER	58.839	18.055

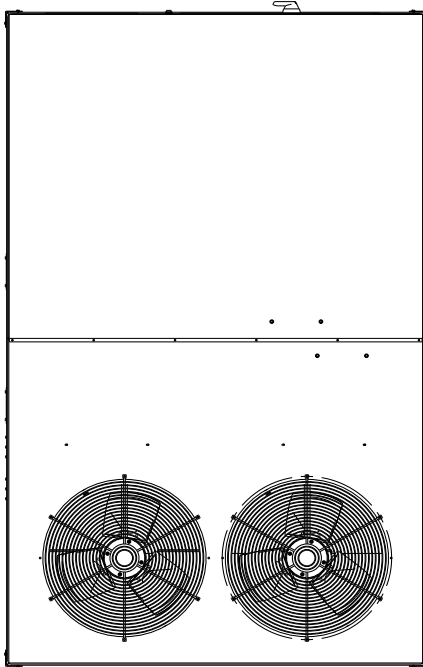

TOP VIEW

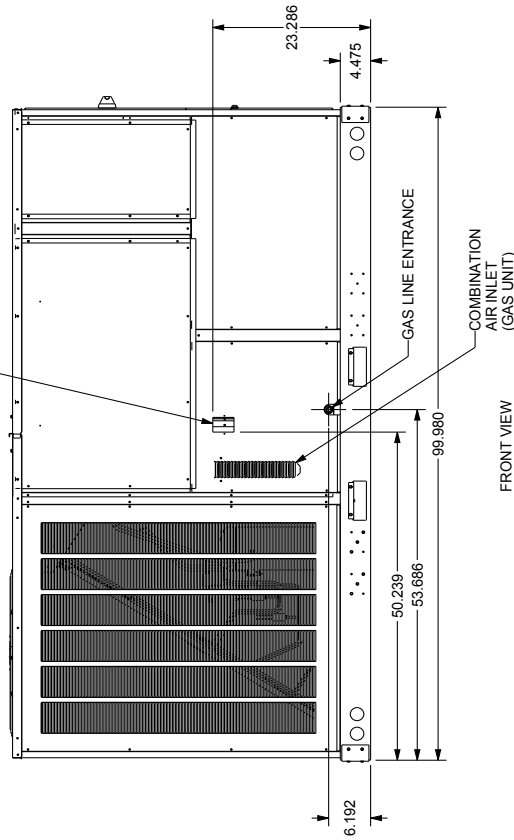
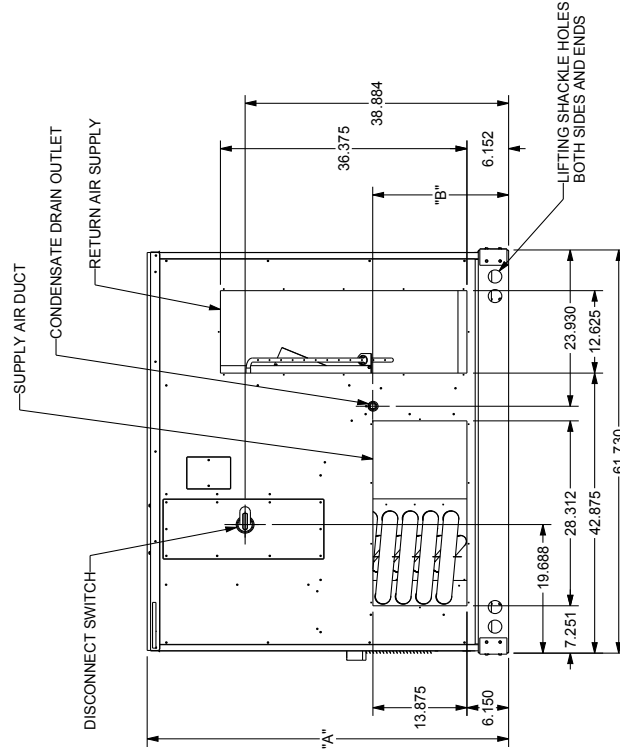

FRONT VIEW

12 1/2 TON USES GRILLE

DC\*090-150\*\*\*  
7.5 THRU 12.5 TON COMMERCIAL

ALL DIMENSIONS GIVEN ARE IN INCHES  
ALL DIMENSIONS AND SPECIFICATIONS ARE SUBJECT TO CHANGE WITHOUT NOTICE

Maintain an adequate clearance around the unit for safety, service, maintenance, and proper unit operation. Leave a clearance of 48" on all sides of the unit for possible compressor removal or service access, and to ensure proper ventilation and condenser airflow. Do not install the unit beneath any obstruction. Install the unit away from all building exhausts to inhibit ingestion of exhaust air into the unit's fresh-air intake.

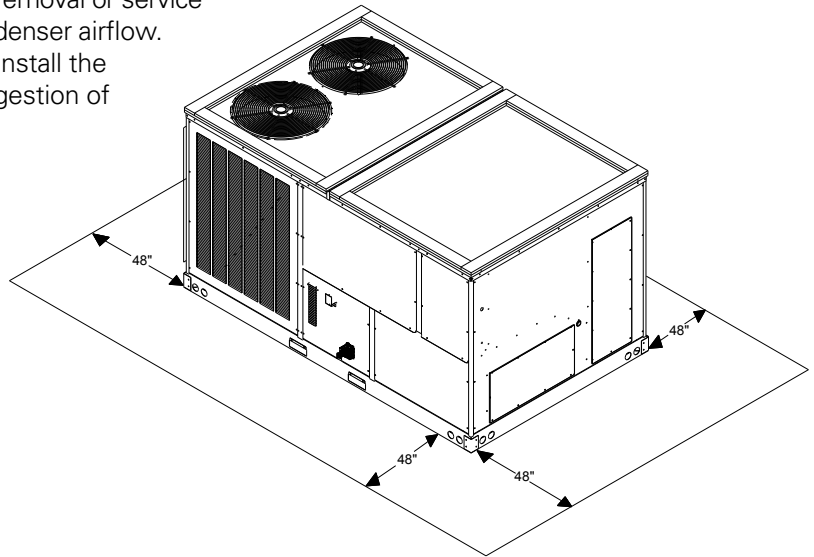

ELECTRICAL ENTRANCE LOCATIONS

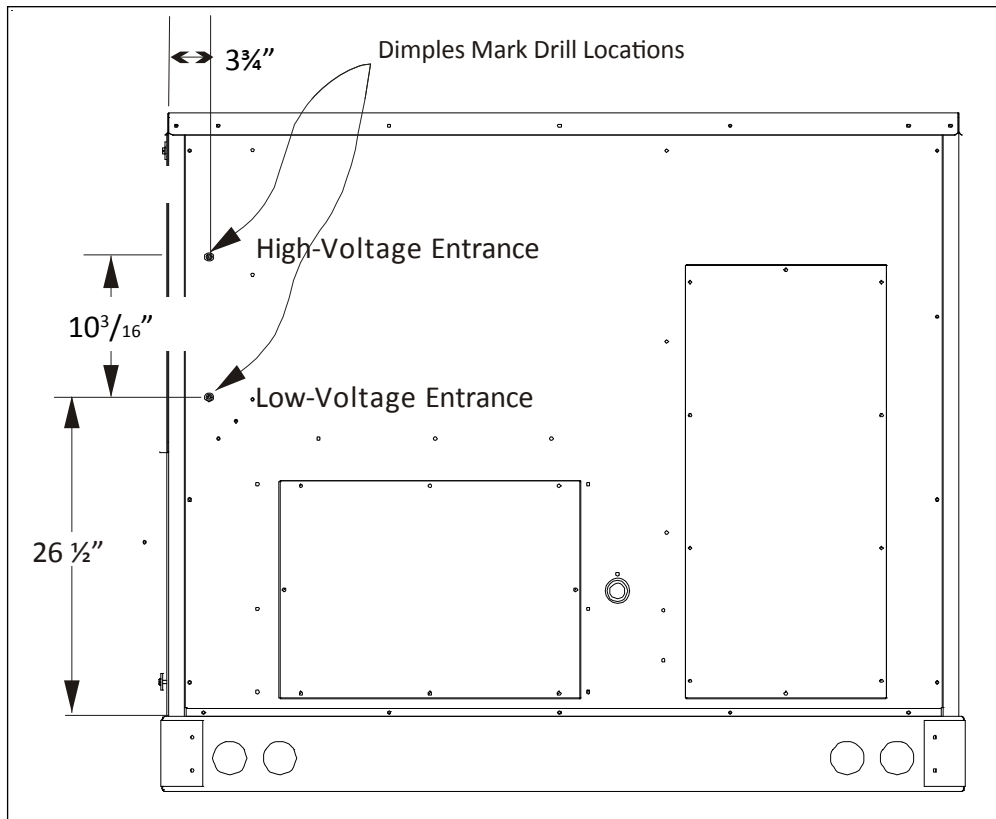



Provisions for forks have been included in the unit base frame. No other fork locations are approved.

- Unit must be lifted by the four lifting holes located at the base frame corners.
- Lifting cables should be attached to the unit with shackles.
- The distance between the crane hook and the top of the unit must not be less than 60”.
- Two spreader bars must span over the unit to prevent damage to the cabinet by the lift cables. Spreader bars must be of sufficient length so that cables do not come in contact with the unit during transport. Remove wood struts mounted beneath unit base frame before setting unit on roof curb. These struts are intended to protect unit base frame from fork lift damage. To remove the struts, extract the sheet metal retainers and pull the struts through the base of the unit. Refer to rigging label on the unit.

**Important:** If using bottom discharge with roof curb, duct-work should be attached to the curb prior to installing the unit. Duct-work dimensions are shown in Roof Curb Installation Instructions Manual.

Refer to the Roof Curb Installation Instructions for proper curb installation.

Curbing must be installed in compliance with the National Roofing Contractors Association Manual.

Lower unit carefully onto roof mounting curb. While rigging the unit, the center of gravity will cause the condenser end to be lower than the supply air end.

Bring condenser end of unit into alignment with the curb. With condenser end of the unit resting on curb member and using curb as a fulcrum, lower opposite end of the unit until entire unit is seated on the curb. When a rectangular cantilever curb is used, take care to center the unit. Check for proper alignment and orientation of supply and return openings with duct.

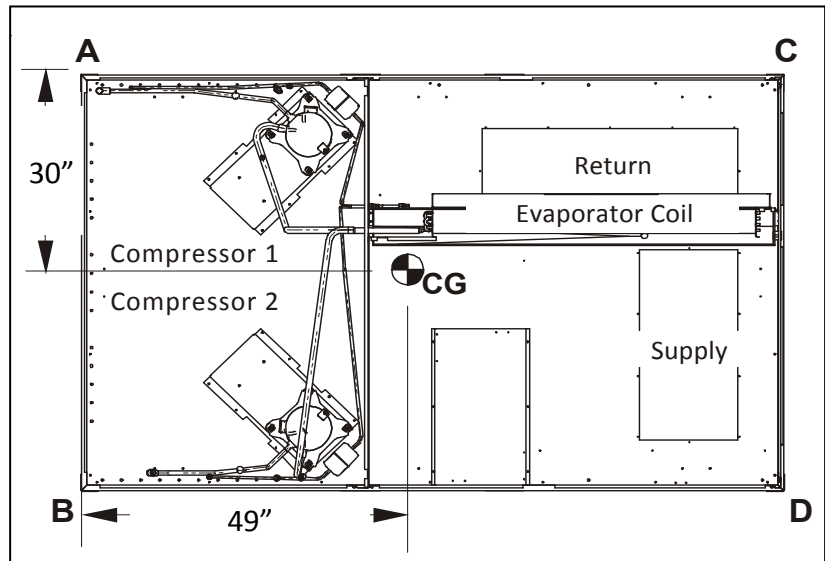
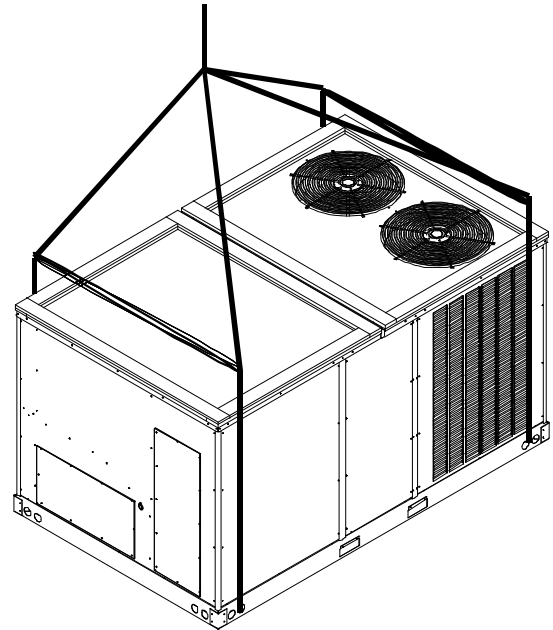

CORNER & CENTER-OF-GRAVITY LOCATIONS

UNIT WEIGHTS	7½-TON WEIGHTS (LBS)	8½-TON WEIGHTS (LBS)	10-TON WEIGHTS (LBS)	12½-TON WEIGHTS (LBS)
Weight A	285	345	345	435
Weight B	285	325	325	345
Weight C	285	320	320	300
Weight D	285	300	300	240
Shipping Weight	1175	1310	1310	1350
Operating Weight	1135	1285	1285	1325

Note: These weights are calculated without accessories installed.

Curb installations must comply with local codes and should follow the established guidelines of the National Roofing Contractors Association.

Proper unit installation requires that the roof curb be firmly and permanently attached to the roof structure. Check for adequate fastening method prior to setting the unit on the curb.

Full perimeter roof curbs are available from the factory and are shipped unassembled. The installing contractor is responsible for field assembly, squaring, leveling, and mounting on the roof structure. All required hardware necessary for the assembly of the sheet metal curb is included in the curb accessory package.

- Determine sufficient structural support before locating and mounting the curb and package unit.
- Duct-work must be constructed using industry guidelines. The duct-work must be placed into the roof curb before mounting the package unit. Our full perimeter curbs include duct connection frames to be assembled with the curb. Cantilevered-type curbs are not available from the factory.
- Contractor furnishes curb insulation, cant strips, flashing, and general roofing material.
- Support curbs on parallel sides with roof members. To prevent damage to the unit, the roof members cannot penetrate supply and return duct openings.

**Note:** The unit and curb accessories are designed to allow vertical duct installation before unit placement. Duct installation after unit placement is not recommended.

3-D VIEW

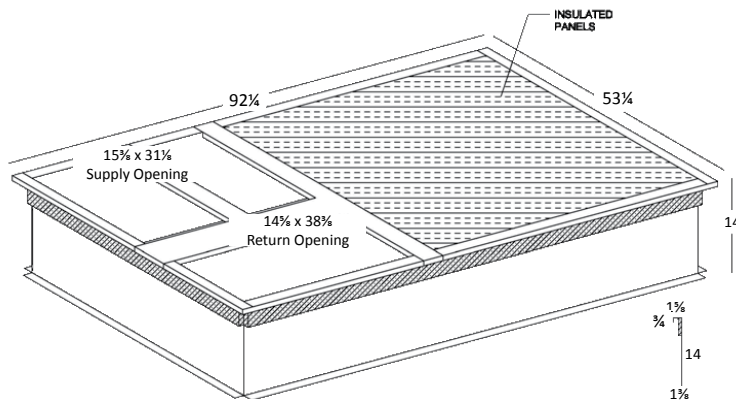

See the manual shipped with the roof curb for assembly and installation instructions.

TOP VIEW

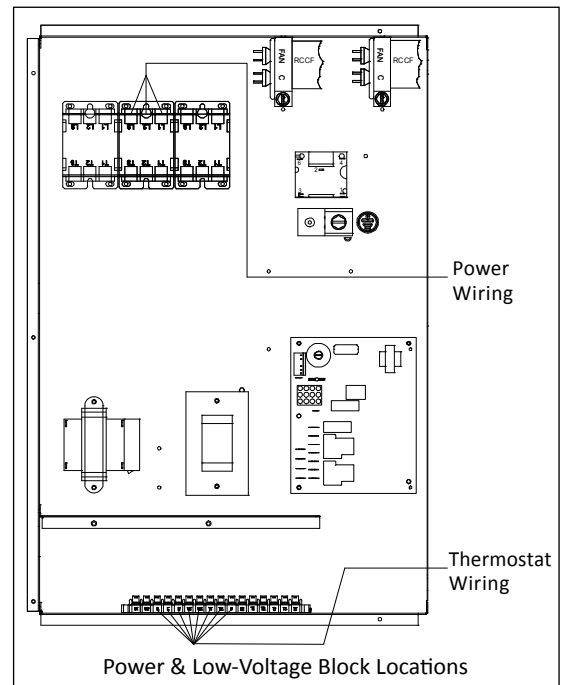
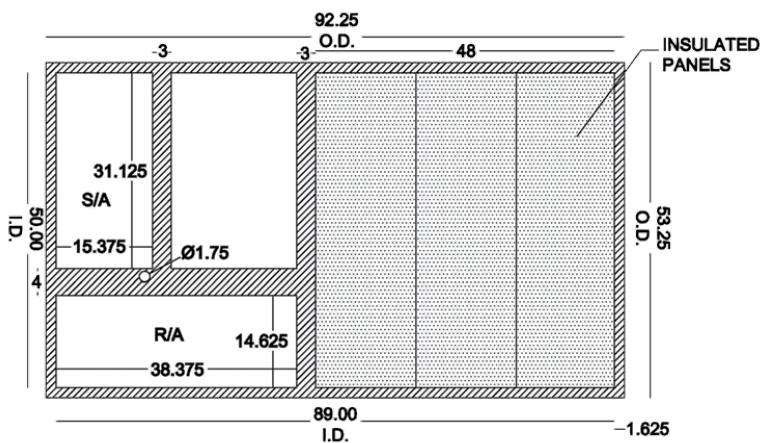

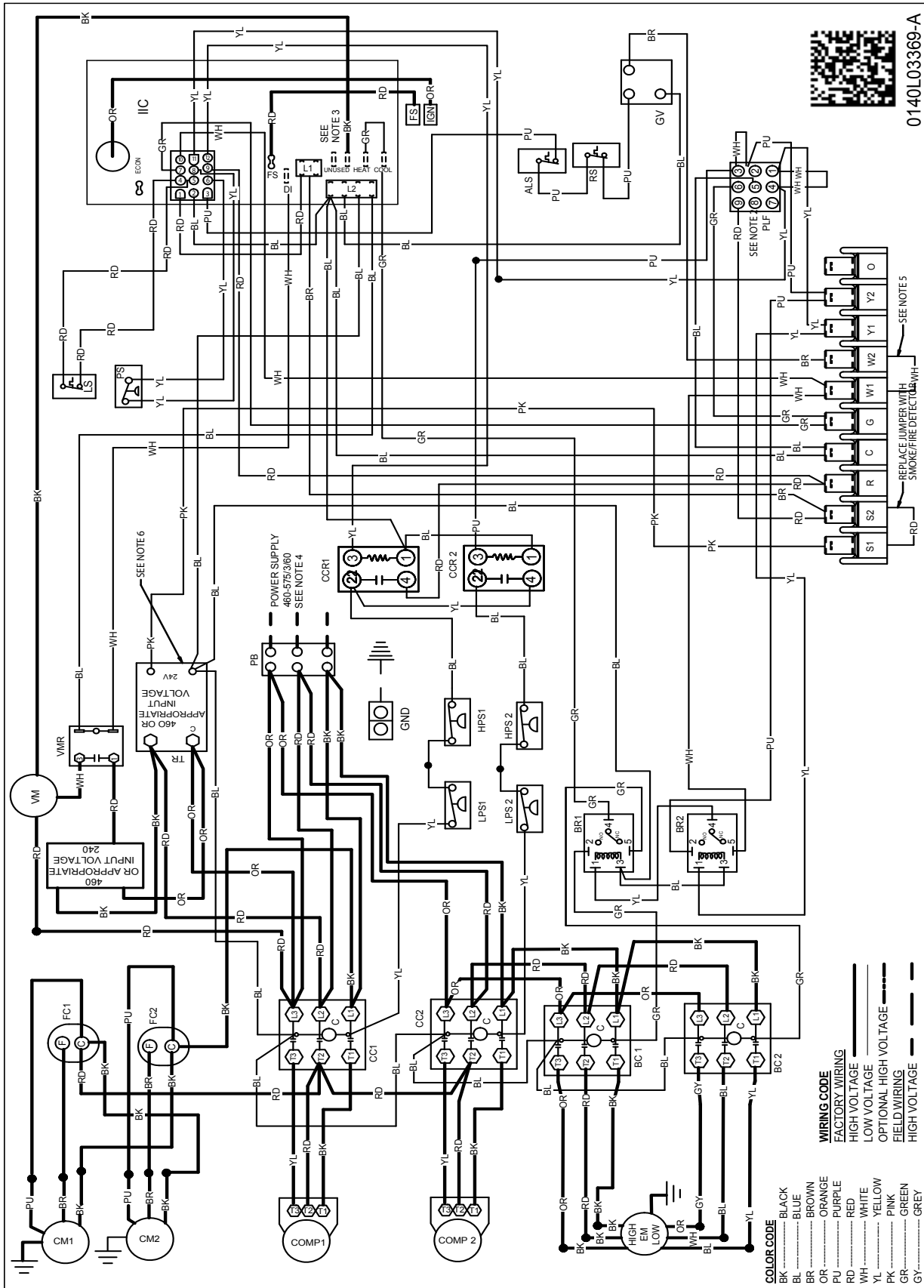

**WARNING**  High Voltage: Disconnect all power before servicing or installing this unit. Multiple power sources may be present. Failure to do so may cause property damage, personal injury, or death. 

Wiring is subject to change. Always refer to the wiring diagram on the unit for the most up-to-date wiring.

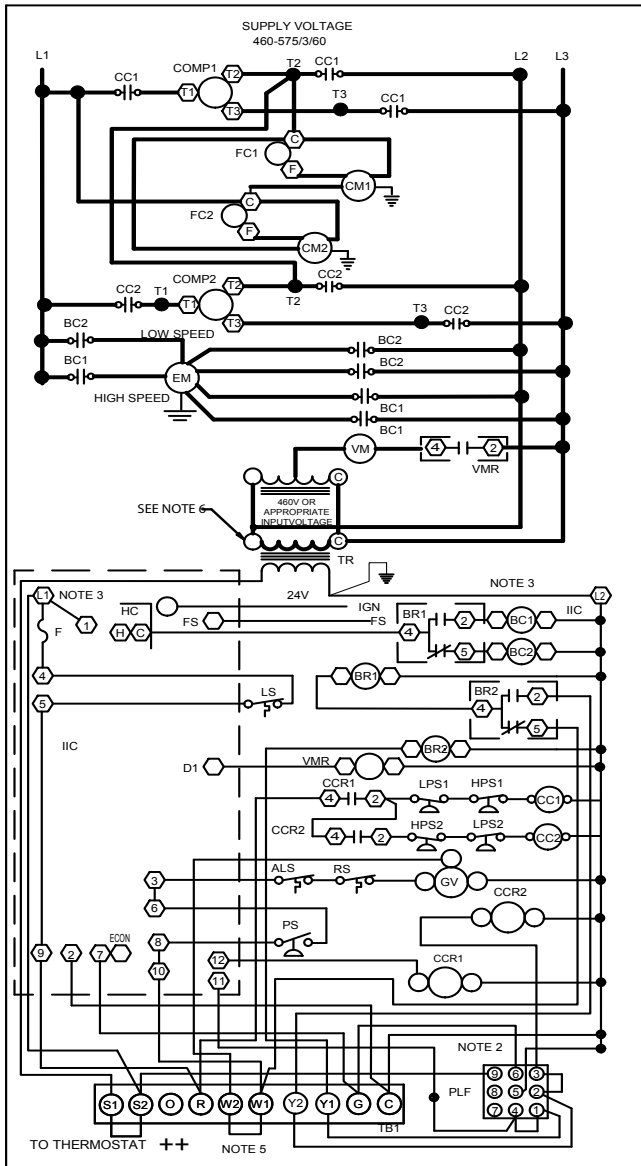

INSTALLER/SERVICEMAN  
 THE STATUS LIGHT ON THE FURNACE CONTROL MAY BE USED AS A GUIDE TO TROUBLESHOOTING THIS APPLIANCE. STATUS LIGHT CODES ARE AS FOLLOWS:

STATUS LIGHT	EQUIPMENT STATUS	CHECK
ON	NORMAL OPERATION	----
OFF	NO POWER OR INTERNAL CONTROL	CHECK INPUT POWER CHECK FUSE ON CONTROL REPLACE CONTROL
1 BLINK	IGNITION FAILURE	GAS FLOW GAS PRESSURE GAS VALVE
	OPEN ROLLOUT SWITCH OPEN AUX. LIMIT SWITCH	FLAME SENSOR FLAME ROLLOUT BAD SWITCH AUX. LIMIT OPEN
2 BLINKS	PRESSURE SWITCH OPEN	CHECK PRESSURE SWITCH
3 BLINKS	PRESSURE SWITCH CLOSED WITHOUT INDUCER ON	CHECK PRESSURE SWITCH
4 BLINKS	OPEN LIMIT SWITCH	MAIN LIMIT OPEN BAD SWITCH
5 BLINKS	FALSE FLAME SENSED	STICKING GAS VALVE
6 BLINKS	COMPRESSOR OUTPUT DELAY	3 MIN. COMP. ANTI-CYCLE TIMER

- COMPONENT LEGEND**
- ALS AUXILIARY LIMIT SWITCH
  - BC BLOWER CONTACTOR
  - BR BLOWER RELAY
  - CB CIRCUIT BREAKER
  - CC COMPRESSOR CONTACTOR
  - CCR COMPRESSOR CONTACTOR RELAY
  - CM COMPRESSOR MOTOR
  - COMP COMPRESSOR
  - EM EVAPORATOR MOTOR
  - F FUSE
  - FC FAN CAPACITOR
  - FS FLAME SENSOR
  - GND EQUIPMENT GROUND
  - GV GAS VALVE
  - HPS HIGH PRESSURE SWITCH
  - IBR INDOOR BLOWER RELAY
  - IIC INTEGRATED IGNITION CONTROL
  - IGN IGNITOR
  - LPS LOW PRESSURE SWITCH
  - LS LIMIT SWITCH
  - PLF FEMALE PLUG/CONNECTOR
  - PS PRESSURE SWITCH
  - RS ROLLOUT SWITCH
  - TB1 TERMINAL BLOCK (24V SIGNAL)
  - TR TRANSFORMER
  - VM VENT MOTOR
  - VMR VENT MOTOR RELAY

- FACTORY WIRING**
- LINE VOLTAGE
  - LOW VOLTAGE
- OPTIONAL HIGH VOLTAGE**
- HIGH VOLTAGE
  - LOW VOLTAGE
- FIELD WIRING**
- HIGH VOLTAGE
  - LOW VOLTAGE
- WIRE CODE**
- BK BLACK
  - BL BLUE
  - BR BROWN
  - GR GREEN
  - OR ORANGE
  - PK PINK
  - PU PURPLE
  - RD RED
  - WH WHITE
  - YL YELLOW
  - YL /PK YELLOW WITH PINK STRIP
  - BL /PK BLUE WITH PINK STRIP

- NOTES**
- REPLACEMENT WIRE MUST BE THE SAME SIZE AND TYPE OF INSULATION AS ORIGINAL. (USE COPPER CONDUCTOR ONLY).
  - ACCESSORY ECONOMIZER PLUG ADJACENT TO BLOWER HOUSING IN RETURN AIR COMPARTMENT. REMOVE MALE PLUG AND ATTACH FEMALE PLUG TO THE ECONOMIZER ACCESSORY.
  - L1 AND L2 ON IIC CONTROL IS 24V INPUT.
  - USE COPPER CONDUCTORS ONLY. ++ USE NEC CLASS 2 WIRE.
  - FOR TWO STAGE OPERATION REMOVE W1 TO W2 JUMPER WIRE.
  - MOVE WIRE(S) TO APPROPRIATE INPUT VOLTAGE TERMINAL ON TRANSFORMER.

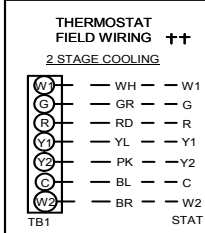

SEE UNIT RATING PLATE FOR TYPE AND SIZE OF OVER CURRENT PROTECTION



460-575/3/60 0140L03370-A

**High Voltage:** Disconnect all power before servicing or installing this unit. Multiple power sources may be present. Failure to do so may cause property damage, personal injury, or death.

**WARNING**

Wiring is subject to change. Always refer to the wiring diagram on the unit for the most up-to-date wiring.

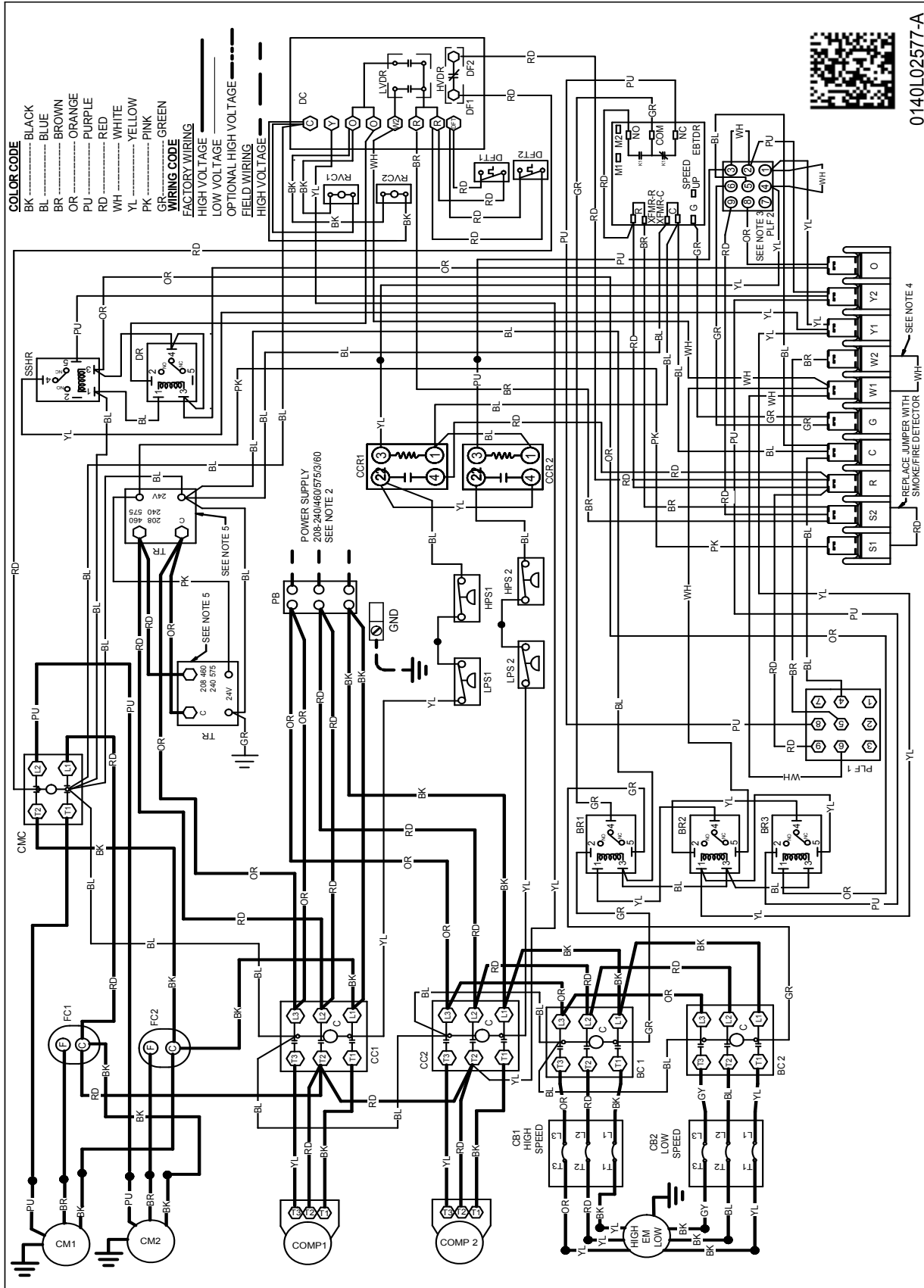

Wiring is subject to change. Always refer to the wiring diagram on the unit for the most up-to-date wiring.

**WARNING**

**High Voltage:** Disconnect all power before servicing or installing this unit. Multiple power sources may be present. Failure to do so may cause property damage, personal injury, or death.

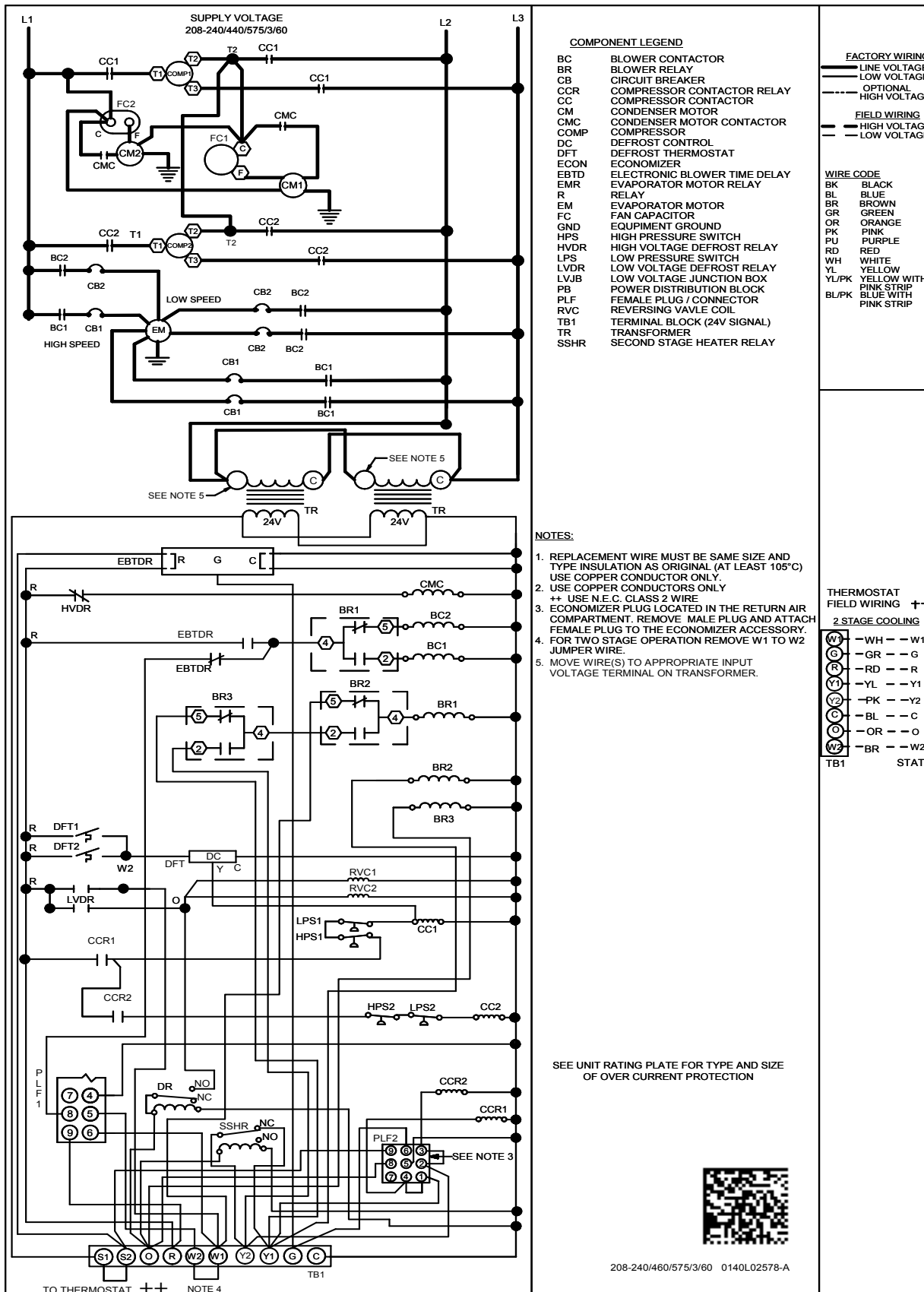

**High Voltage:** Disconnect all power before servicing or installing this unit. Multiple power sources may be present. Failure to do so may cause property damage, personal injury, or death.

**WARNING**

Wiring is subject to change. Always refer to the wiring diagram on the unit for the most up-to-date wiring.

---

## *WIRING DIAGRAMS FOR MODELS WITH DDC CONTROLS*

FOR COMPLETE INFORMATION AND INSTALLATION INSTRUCTIONS FOR MODELS  
WITH DDC CONTROLS, SEE MANUAL DK-DDC-TGD-XXX

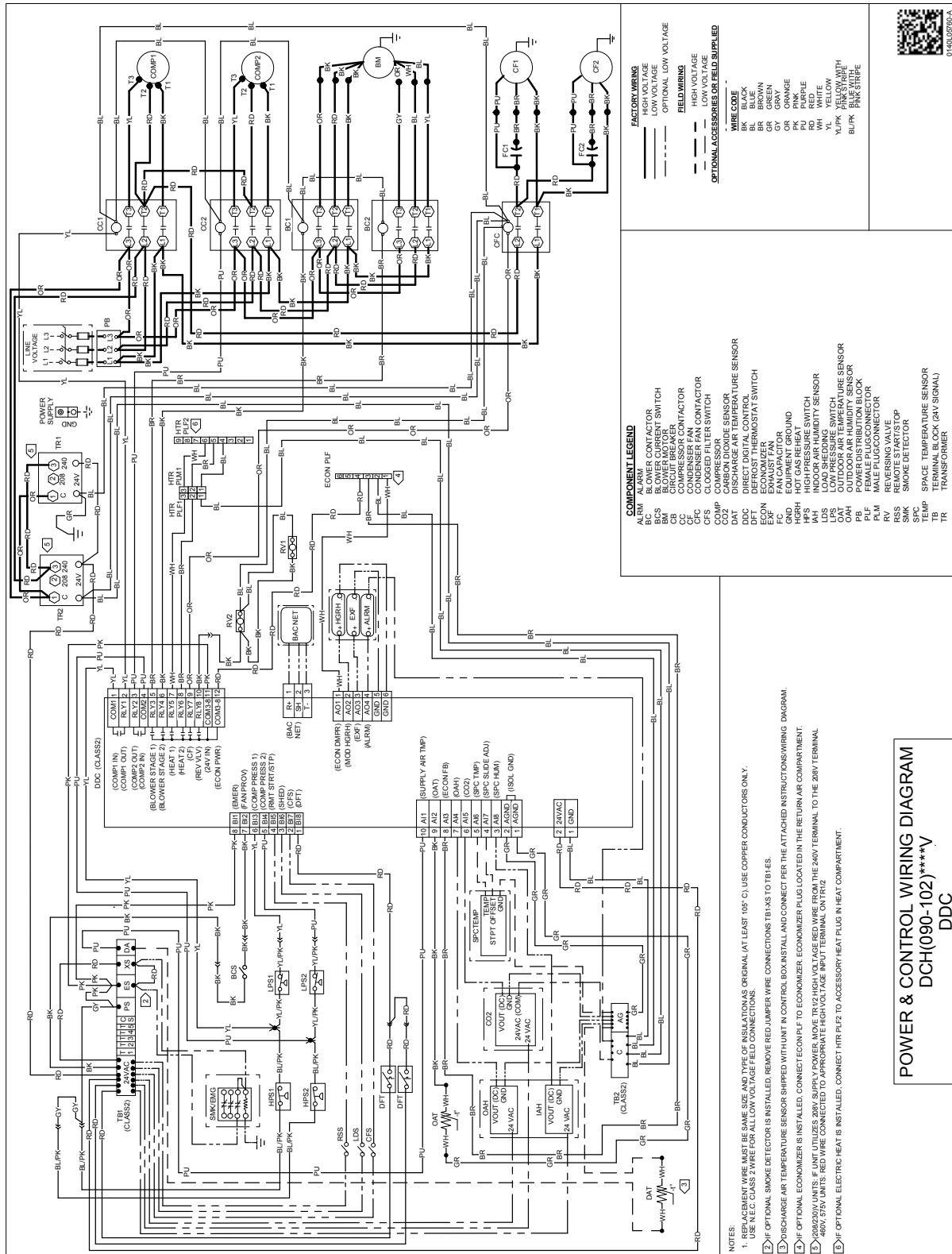

**POWER & CONTROL WIRING DIAGRAM**  
DCH(090-102)\*\*\*\*V  
DDC

High Voltage: Disconnect all power before servicing or installing this unit. Multiple power sources may be present. Failure to do so may cause property damage, personal injury, or death.

Warning symbol: ⚡

Wiring is subject to change. Always refer to the wiring diagram on the unit for the most up-to-date wiring.



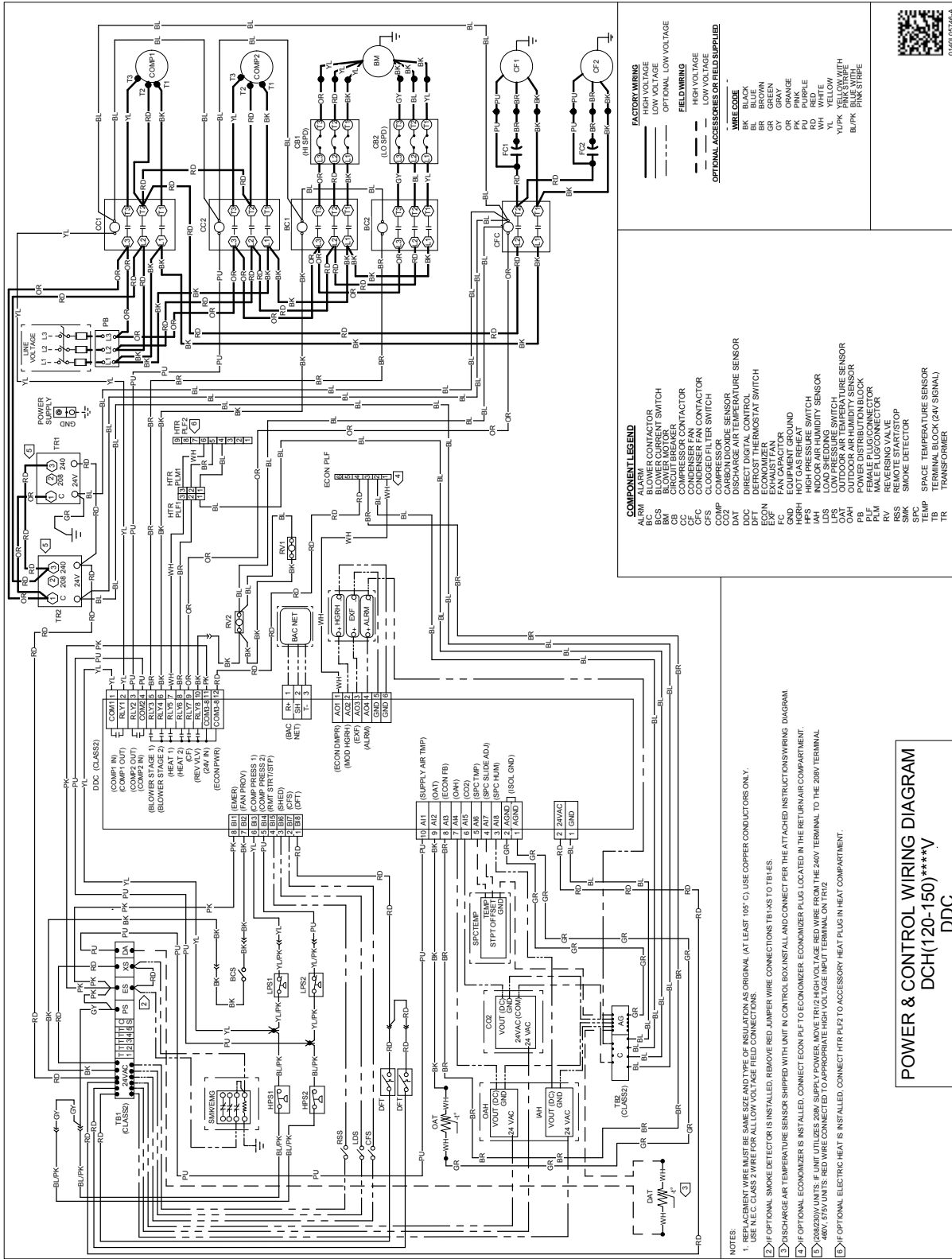

**POWER & CONTROL WIRING DIAGRAM**  
DCH(120-150) \*\*\*\*V  
DDC

**WARNING**  
High Voltage: Disconnect all power before servicing or installing this unit. Multiple power sources may be present. Failure to do so may cause property damage, personal injury, or death.

Wiring is subject to change. Always refer to the wiring diagram on the unit for the most up-to-date wiring.

- NOTES:
1. REPLACEMENT WIRE MUST BE SAME SIZE AND TYPE OF INSULATION AS ORIGINAL. (AT LEAST 105° C). USE COPPER CONDUCTORS ONLY.
  2. IF OPTIONAL SMOKE DETECTOR IS INSTALLED, REMOVE RED JUMPER WIRE CONNECTIONS TB1-AS TO TB1-ES.
  3. IF DISCHARGE AIR TEMPERATURE SENSOR SHIPPED WITH UNIT IN CONTROL BOX, INSTALL AND CONNECT PER THE ATTACHED INSTRUCTIONS WIRING DIAGRAM.
  4. IF OPTIONAL ECONOMIZER IS INSTALLED, CONNECT ECON PLF TO ECONOMIZER. ECONOMIZER PLUG LOCATED IN THE RETURN AIR COMPARTMENT.
  5. IF 208/230V UNITS, F. LINT UTILIZES 208V SUPPLY POWER. MOVE TR1/12 HIGH VOLTAGE RED WIRE FROM THE 240V TERMINAL TO THE 208V TERMINAL.
  6. IF OPTIONAL ELECTRIC HEAT IS INSTALLED, CONNECT HTR PLF2 TO ACCESSORY HEAT PLUG IN HEAT COMPARTMENT.

**FACTORY WIRING**  
HIGH VOLTAGE  
OPTIONAL LOW VOLTAGE  
**FIELD WIRING**  
HIGH VOLTAGE  
LOW VOLTAGE  
**OPTIONAL ACCESSORIES OR FIELD SUPPLIED**

**WIRE CODE**  
BK BLACK  
BR BROWN  
GR GREEN  
OR ORANGE  
PK PINK  
RD RED  
WH WHITE  
Y/PK YELLOW WITH PINK STRIPE  
BL/PK PINK STRIPE

**COMPONENT LEGEND**  
ACM AIR CURTAIN MOTOR  
BC BLOWER CONTACTOR  
BCCS BLOWER CURRENT SWITCH  
CB CIRCUIT BREAKER  
CC COMPRESSOR CONTACTOR  
CFC CONDENSER FAN CONTACTOR  
CFCF CONDENSER FAN CONTACTOR  
COMP COMPRESSOR  
COOP COOLING OPERATOR  
DAT DIRECT DIGITAL CONTROL  
DDC DIRECT DIGITAL CONTROL  
ECON ECONOMIZER  
EXP EXHAUST FAN  
FC FAN CONTACTOR  
FCO EQUIPMENT GROUND  
HGRH HOT GAS REHEAT  
HPS HIGH PRESSURE SWITCH  
LPS LOW PRESSURE SWITCH  
LDS LOAD SHEDDING  
OAH OUTDOOR AIR HUMIDITY SENSOR  
OAH OUTDOOR AIR HUMIDITY SENSOR  
PB POWER DISTRIBUTION BLOCK  
PLM MAIN LINE MOTOR  
PLM MAIN LINE MOTOR  
RV REVERSING VALVE  
RSS REMOTE START/STOP  
SSM SMOKE DETECTOR  
SPC SPACE TEMPERATURE SENSOR  
TEMP TEMPERATURE SENSOR  
TB TERMINAL BLOCK (24V SIGNAL)  
TR TRANSFORMER

DAIKIN MASTER ITEM #	DESCRIPTION	FITS MODEL SIZES	FIELD- INSTALLED	FACTORY- INSTALLED	OPERATING WEIGHT (LBS)
<b>Curb</b>					
14CURB90150	14" Roof Curb	7½-12½ tons	√		143
18CURB90150	18" Roof Curb	7½-12½ tons	√		165
24CURB90150	24" Roof Curb	7½-12½ tons	√		197
GHRC-90150	Hurricane Restraint Clips	7½-12½ tons	√		2
<b>Ultra Low-Leak Economizer &amp; Power Exhaust¹</b>					
1036610B	Ultra Low-Leak Downflow Economizer w/ Enthalpy	7½-12½ tons	√	√	137
1039610B	Ultra Low-Leak Horizontal Economizer w/ Enthalpy	7½-12½ tons	√		137
104651021	Prop Power Exhaust 230v	7½-12½ tons	√		55
104651031	Prop Power Exhaust 460v	7½-12½ tons	√		55
104651041	Prop Power Exhaust 575v	7½-12½ tons	√		55
<b>Low-Leak Economizer &amp; Power Exhaust²</b>					
DDNECNJ90150B	Low-Leak Downflow Economizer	7½-12½ tons	√	√	130
DPE901502	Downflow Power Exhaust (208/230v)	7½-12½ tons	√		65
DPE901504	Downflow Power Exhaust (460v)	7½-12½ tons	√		65
DPE901507	Downflow Power Exhaust (575v)	7½-12½ tons	√		65
DINH90150B	Horizontal Economizer, Internally Mounted	7½-12½ tons	√		110
DHZECNJ90150	Horizontal Economizer	7½-12½ tons	√		90
DHPE901502	Horizontal Power Exhaust (208/230v)	7½-12½ tons	√		65
DHPE901504	Horizontal Power Exhaust (460v)	7½-12½ tons	√		65
DHPE901507	Horizontal Power Exhaust (575v)	7½-12½ tons	√		65
<b>Downflow Accessories</b>					
D25FD90150	25% Manual Fresh Air Damper	7½-12½ tons	√		15
D25MFD90150	25% Motorized Fresh Air Damper	7½-12½ tons	√		21
DDNBBS90150	Burglar Bar Sleeves: includes Supply & Return	7½-12½ tons	√		45
DDNECNJ90150NR	Low-Leak Downflow Economizer w/o Barometric Relief	7½-12½ tons	√		130
DDNSQRD9020	Downflow Square-to-Round Adapter 20" Round	7½ tons	√		55
<b>Horizontal Accessories</b>					
DBRD3672	Horizontal Barometric Relief Damper (2 required)	7½-12½ tons	√		30
<b>Concentrics</b>					
CDK90102	Concentric Duct Kit	7½-8½ tons	√		42
CDK120	Concentric Duct Kit	10 tons	√		104
CDK150	Concentric Duct Kit	12½ tons	√		151
<b>3 phase 208-230V Electric Heat Kits</b>					
EHK3-16	16kw 208-230v 3ph Electric Heat Kit	7½-12½ tons	√	√	21
EHK3-30	30kw 208-230v 3ph Electric Heat Kit	7½-12½ tons	√	√	21
EHK3-45	45kw 208-230v 3ph Electric Heat Kit	7½-12½ tons	√	√	21

DAIKIN MASTER ITEM #	DESCRIPTION	FITS MODEL SIZES	FIELD- INSTALLED	FACTORY- INSTALLED	OPERATING WEIGHT (LBS)
<b>3 phase 460V Electric Heat Kits</b>					
EHK4-16	16kw 460v 3ph Electric Heat Kit	7½-12½ tons	√	√	21
EHK4-30	30kw 460v 3ph Electric Heat Kit	7½-12½ tons	√	√	21
EHK4-45	45kw 460v 3ph Electric Heat Kit	7½-12½ tons	√	√	21
<b>3 phase 575V Electric Heat Kits</b>					
EHK7-16	16kw 575v 3ph Electric Heat Kit	7½-12½ tons	√	√	21
EHK7-30	30kw 575v 3ph Electric Heat Kit	7½-12½ tons	√	√	21
EHK7-45	45kw 575v 3ph Electric Heat Kit	7½-12½ tons	√	√	21
<b>DDC Accessories<sup>3</sup></b>					
	DDC communicating controller (built-in BACnet® MS/TP) includes Standard Room Sensor to be installed in field	7½-12½ tons		√	2
10366D10B	DDC Ultra Low-Leak Downflow Economizer	7½-12½ tons	√	√	71
10396D10	DDC Ultra Low-Leak Horizontal Economizer	7½-12½ tons	√		71
10465DDC	Power Exhaust kit used with DDC Ultra Low-Leak Economizer	7½-12½ tons	√		1
DLAKT03	Low-Ambient	7½-12½ tons	√	√	2
LONKT01	LonWorks® card	7½-12½ tons	√		1
3PMK01	Phase Monitor (3-Phase Only)	7½-12½ tons	√	√	2
DFSKT01	Dirty Filter Switch	7½-12½ tons	√		1
<b>High-Static Kits</b>					
HSKTW090FI	High Static, Factory Installed (230/460/575v)	7½ tons		√	10
HSKTW102FI	High Static, Factory Installed (230/460/575v)	8½ tons		√	10
HSKTW120-3FIHP	High Static, Factory Installed (208/230v)	10 tons HP		√	60
HSKTW120-4FIHP	High Static, Factory Installed (460v)	10 tons HP		√	60
HSKTW120-7FIHP	High Static, Factory Installed (575v)	10 tons HP		√	60
HSKTW150-3FI	High Static, Factory Installed (230v)	12½ tons		√	40
HSKTW150-4FI	High Static, Factory Installed (460v)	12½ tons		√	40
HSKTW150AC-7FI	High Static, Factory Installed (575v)	12½ tons AC/HP		√	35
<b>Crankcase Heater Kits</b>					
0130L00017S	70W 230V	7½-12½ tons	√		1
0130L00018S	70W 460V	7½-12½ tons	√		1
0130L00019S	70W 575V	7½-12½ tons	√		1
<b>High Efficiency Filters</b>					
0160L00205	High Efficiency MERV 13 Air Filter Nom. Size: 16x20x2; (Order Qty 4)	7.5 tons	√		4
0160L00206	High Efficiency MERV 13 Air Filter Nom. Size: 16x24x2; (Order Qty 4)	8.5 & 10 tons	√		4
0160L00202	High Efficiency MERV 13 Air Filter Nom. Size: 20x25x2; (Order Qty 4)	12.5 tons	√		6

DAIKIN MASTER ITEM #	DESCRIPTION	FITS MODEL SIZES	FIELD- INSTALLED	FACTORY- INSTALLED	OPERATING WEIGHT (LBS)
<b>Misc Accessories</b>					
HailGD02D	Condenser Coil Hail Guard	7½-10 tons	√		34
HailGD05D	Condenser Coil Hail Guard	12½ tons	√		37
	Convenience Outlet: Powered	7½-12½ tons		√	42
	Convenience Outlet: Non Powered	7½-12½ tons		√	2
	Disconnect Switch (non-fused)	7½-12½ tons		√	5
LAKT17	Low-Ambient Kit, 208-230V - non-DDC	7½-8½ tons	√	√	23
LAKT18	Low-Ambient Kit, 460V - non-DDC	7½-8½ tons	√	√	23
LAKT19	Low-Ambient Kit, 575V - non-DDC	7½-8½ tons	√	√	23
LAKT20	Low-Ambient Kit, 208-230V - non-DDC	10-12½ tons	√	√	23
LAKT21	Low-Ambient Kit, 460V - non-DDC	10-12½ tons	√	√	23
LAKT22	Low-Ambient Kit, 575V - non-DDC	10-12½ tons	√	√	23
3PMNDK01	Phase Monitor - Non DDC	7½-12½ tons	√	√	2
	Smoke Detector (supply and/or return air)	7½-12½ tons		√	11
	Hinged Panels	7½-12½ tons		√	34

<sup>1</sup> Use Economizer & Power Exhaust listed within Ultra Low-Leak section

<sup>2</sup> Use Economizer & Power Exhaust listed within Low-Leak section

<sup>3</sup> For a full list of DDC accessories, please refer to DDC Controller Technical Guide manual (DK-DDC-TGD-01B)

**Note:** Where multiple variations are available, the heaviest combination is listed.