



SERVICE MANUAL

R410A

Outdoor unit
[Model Name]

SUZ-KA09NA2
SUZ-KA09NAH2

SUZ-KA12NA2
SUZ-KA12NAH2

SUZ-KA15NA2
SUZ-KA15NAH2

[Service Ref.]

SUZ-KA09NA2.MX
SUZ-KA09NAH2.MX

SUZ-KA12NA2.MX
SUZ-KA12NAH2.MX

SUZ-KA15NA2.MX
SUZ-KA15NAH2.MX

Note:

- This service manual describes service data of the outdoor units only.

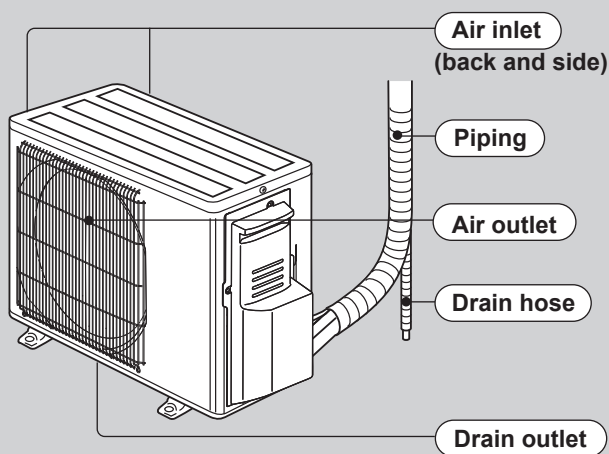

SUZ-KA09NA(H)2.MX

CONTENTS

1. COMBINATION OF INDOOR AND OUTDOOR UNITS...	2
2. PART NAMES AND FUNCTIONS.....	2
3. SPECIFICATION.....	3
4. OUTLINES AND DIMENSIONS.....	4
5. WIRING DIAGRAM.....	5
6. REFRIGERANT SYSTEM DIAGRAM.....	9
7. DATA.....	10
8. ACTUATOR CONTROL.....	12
9. SERVICE FUNCTION.....	13
10. TROUBLESHOOTING.....	13
11. FUNCTION SETTING.....	29
12. DISASSEMBLY INSTRUCTIONS.....	32

PARTS CATALOG (OCB699)

1 COMBINATION OF INDOOR AND OUTDOOR UNITS

	Indoor unit		Outdoor unit		
			Heat pump type		
	Service Ref.	Service Manual No.	SUZ-		
KA09 NA(H)2.MX			KA12 NA(H)2.MX	KA15 NA(H)2.MX	
Heat pump without electric heater	SLZ-KF09/12/15NA.TH	OCH699	○	○	○
	SEZ-KD09/12/15NA4R1.TH	HWE08020	○	○	○
	PEAD-A09/12/15AA7.MX	HWE1608A	○	○	○
	SVZ-KP12NA.MX		—	○	—
	MLZ-KP09/12NA-U1	OBH802	○	○	—

2 PART NAMES AND FUNCTIONS

SUZ-KA09NA(H)2.MX SUZ-KA12NA(H)2.MX SUZ-KA15NA(H)2.MX

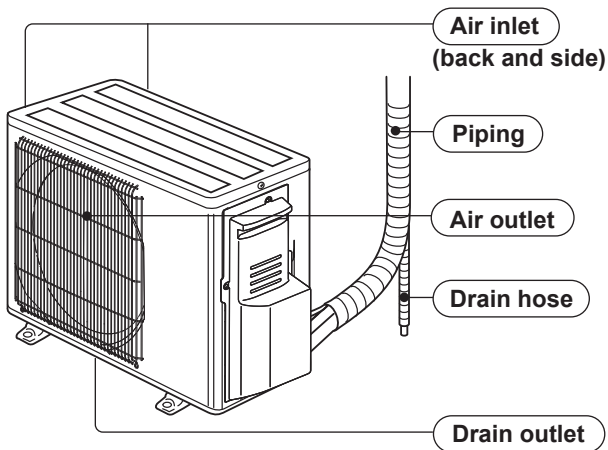

3

SPECIFICATION

Outdoor unit model			SUZ-KA09NA(H)2	SUZ-KA12NA(H)2	SUZ-KA15NA(H)2
Power supply	V , phase , Hz		208/230 , 1 , 60		
Max. fuse size (time delay)	A		15		
Min. circuit ampacity	A		9	9	10
Fan motor	F.L.A		0.50		
Compressor	Model		KNB073FRVMC	SNB092FQAMT	SNB130FQBMT
		R.L.A	6.2	6.6	7.4
		L.R.A	7.7	8.2	9.3
		Refrigeration oil oz(L)/ (Model)	9.1(0.27)/(FV50S)	11.8(0.35)/(FV50S)	11.8(0.35)/(FV50S)
Refrigerant control			Linear expansion valve		
Sound level*1	Cooling	dB(A)	48	49	49
	Heating	dB(A)	50	51	51
Defrost method			Reverse cycle		
Dimensions	W	in	31-1/2		
	D	in	11-1/4		
	H	in	21-5/8		
Weight			81 lb		
External finish			Munsell 3Y 7.8/1.1		
Control voltage (by built-in transformer)	VDC		12 - 24		
Refrigerant piping			Not supplied		
Refrigerant pipe size (Min. wall thickness)	Liquid	in	1/4 (0.0315)		
	Gas	in	3/8 (0.0315)		1/2 (0.0315)
Connection method	Indoor		Flared		
	Outdoor		Flared		
Between the indoor & outdoor units	Height difference	ft	40		
	Piping length	ft	65		
Refrigerant charge (R410A)			2 lb 5 oz		2 lb 9 oz

Note: Test conditions are based on AHRI 210/240.

Rating conditions (Cooling) — Indoor: 80°F D.B., 67°F W.B., Outdoor: 95°F D.B., (75°F W.B.)
 (Heating) — Indoor: 70°F D.B., 60°F W.B., Outdoor: 47°F D.B., 43°F W.B.

OPERATING RANGE

(1) POWER SUPPLY

	Rated voltage	Guaranteed voltage (V)
Outdoor unit	208/230 V 1 phase 60 Hz	Min. 187 208 230 Max. 253

SUZ-KA09NA(H)2.MX SUZ-KA12NA(H)2.MX SUZ-KA15NA(H)2.MX

Unit: inch(mm)

REQUIRED SPACE

*1 4 in. (100 mm) or more when front and sides of the unit are clear

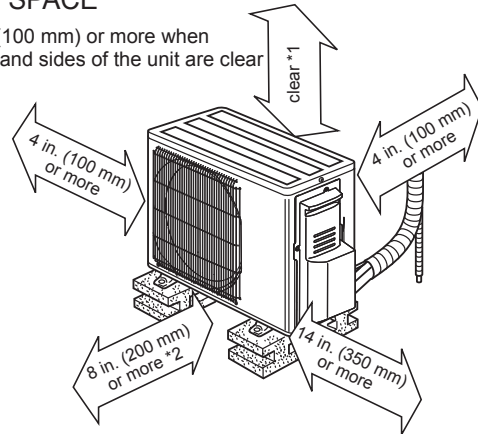

*2 When any 2 sides of left, right and rear of the unit are clear

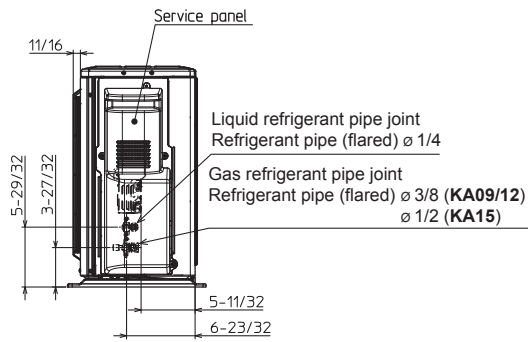
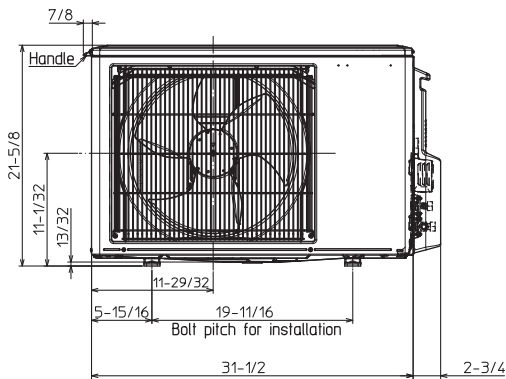
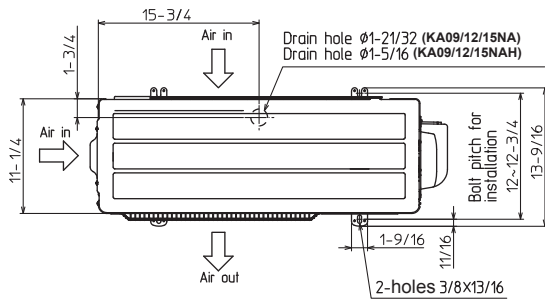

SUZ-KA09NA2.MX SUZ-KA12NA2.MX

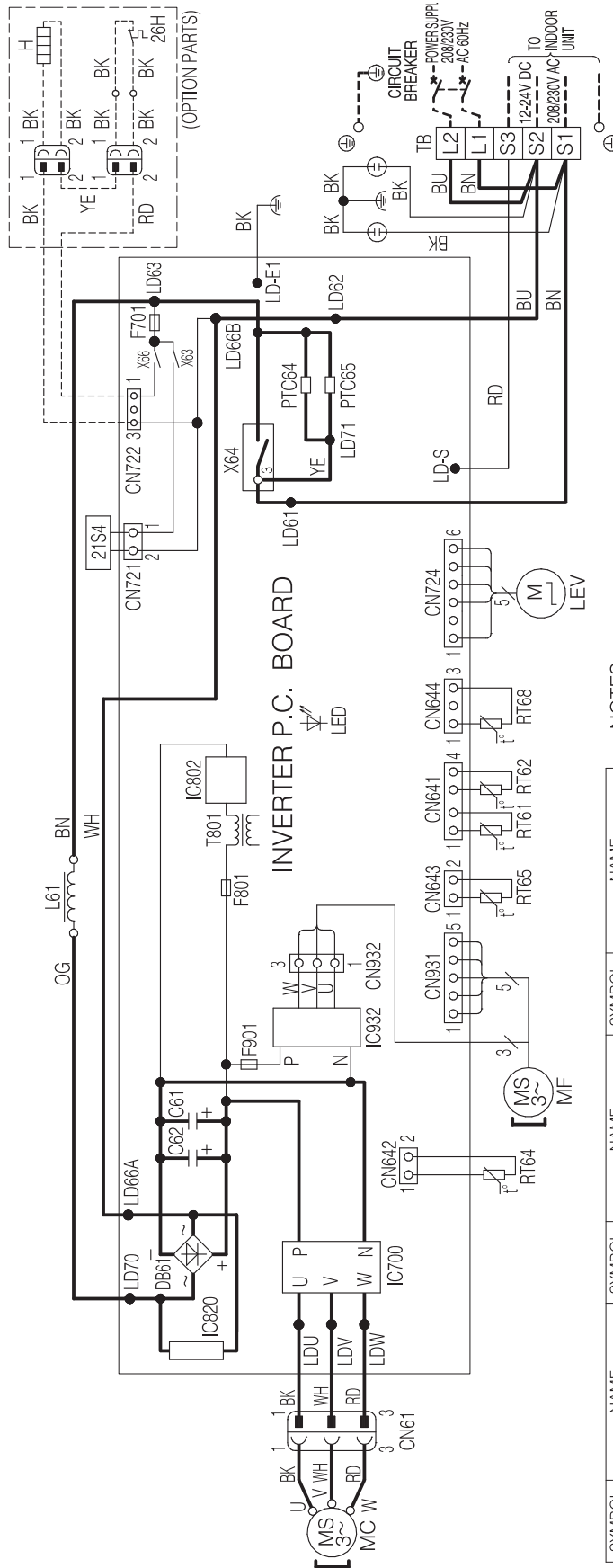

- NOTES :
1. About the indoor side electric wiring, refer to the indoor unit electric wiring diagram for servicing.
 2. Use copper supply wires.
 3. Symbols indicate, : Terminal block : Connector

SYMBOL	NAME	SYMBOL	NAME	SYMBOL	NAME
C61,C62	SMOOTHING CAPACITOR	L61	REACTOR	RT68	OUTDOOR HEAT EXCHANGER TEMP. THERMISTOR
DB61	DIODE MODULE	MC	COMPRESSOR	TB	TERMINAL BLOCK
F701,F801,F901	FUSE (T3, 15AL250V)	MF	FAN MOTOR	T801	TRANSFORMER
IC700,IC802,IC820	POWER MODULE	PTC64, PTC65	CIRCUIT PROTECTION	X63, X64, X66	RELAY
IC802	POWER DEVICE	RT61	DEFROST THERMISTOR	21S4	REVERSING VALVE COIL HEATER PROTECTOR(OPTION PARTS)
LED	LED	RT62	DISCHARGE TEMP. THERMISTOR	26H	HEATER PROTECTOR(OPTION PARTS)
LEV	EXPANSION VALVE COIL	RT64	FIN TEMP. THERMISTOR		
		RT65	AMBIENT TEMP. THERMISTOR		

SUZ-KA09NAH2.MX

SUZ-KA12NAH2.MX

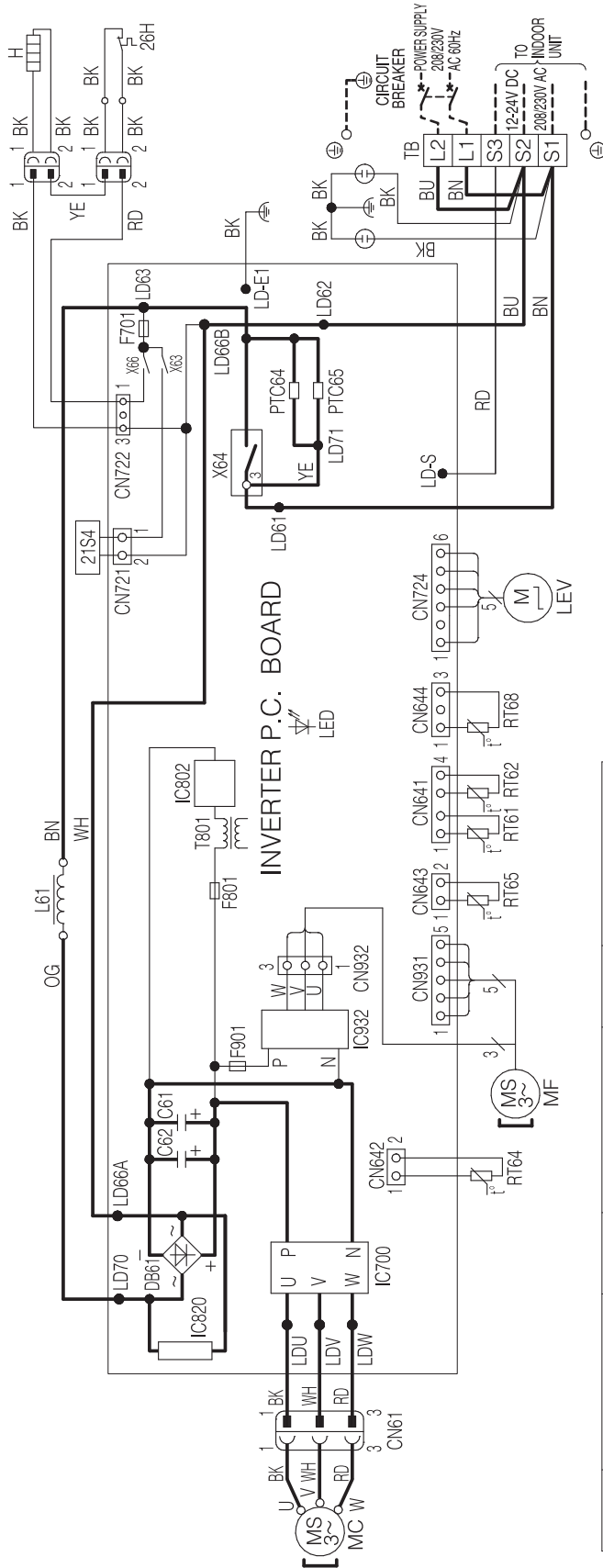

- NOTES :
1. About the indoor side electric wiring, refer to the indoor unit electric wiring diagram for servicing.
 2. Use copper supply wires.
 3. Symbols indicate, : Terminal block : Connector

SYMBOL	NAME	SYMBOL	NAME	SYMBOL	NAME
C61,C62	SMOOTHING CAPACITOR	L61	REACTOR	RT68	OUTDOOR HEAT EXCHANGER
DB61	DIODE MODULE	MC	COMPRESSOR		TEMP. THERMISTOR
F701,F801,F901	FUSE (T3, 15A(L250V))	MF	FAN MOTOR	TB	TERMINAL BLOCK
H	DEFROST HEATER	PTC64, PTC65	CIRCUIT PROTECTION	T801	TRANSFORMER
IC802	POWER MODULE	RT61	DEFROST THERMISTOR	X63, X64, X66	RELAY
LED	LED	RT62	DISCHARGE THERMISTOR	21S4	REVERSING VALVE COIL
LEV	EXPANSION VALVE COIL	RT64	FIN TEMP. THERMISTOR	26H	HEATER PROTECTOR
		RT65	AMBIENT TEMP. THERMISTOR		

SUZ-KA15NA2.MX

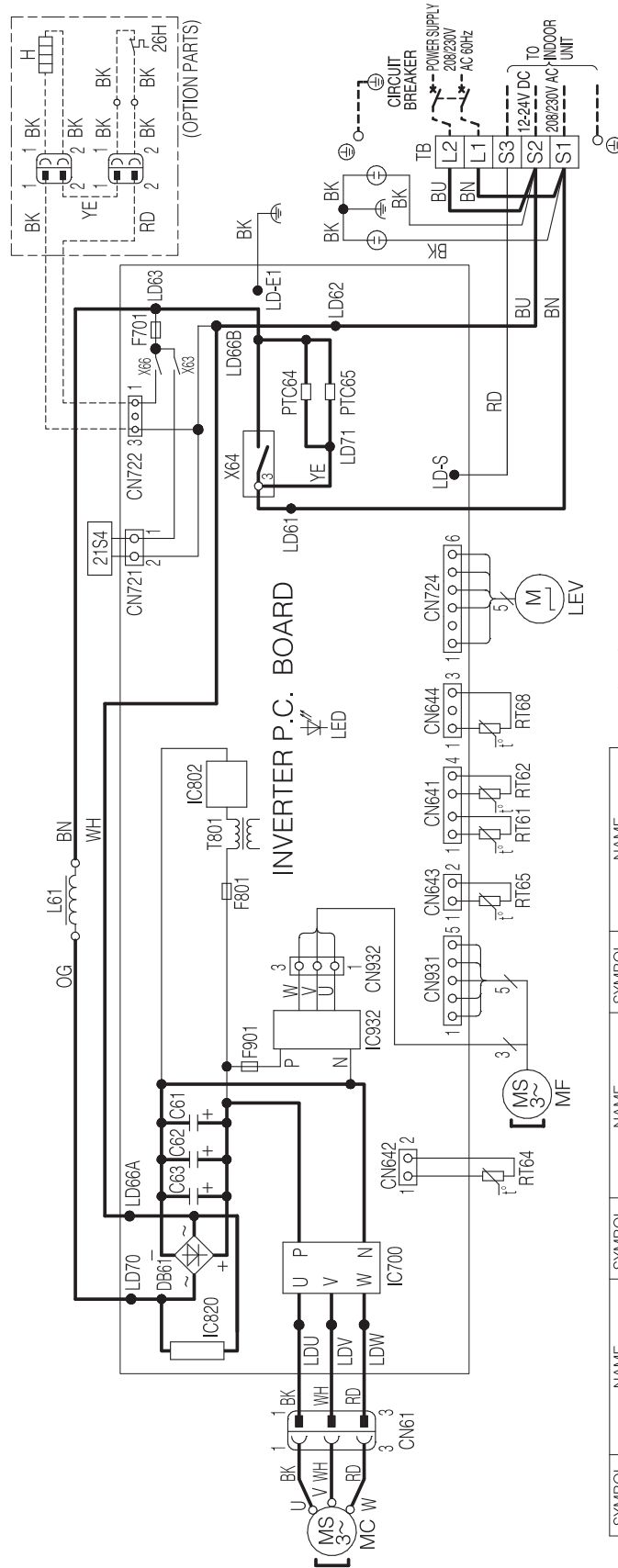

- NOTES :**
1. About the indoor side electric wiring, refer to the indoor unit electric wiring diagram for servicing.
 2. Use copper supply wires.
 3. Symbols indicate, :Terminal block :Connector

SYMBOL	NAME	SYMBOL	NAME	SYMBOL	NAME
C61,C62,C63	SMOOTHING CAPACITOR	L61	REACTOR	RT68	OUTDOOR HEAT EXCHANGER TEMP. THERMISTOR
DB61	DIODE MODULE	MC	COMPRESSOR	TB	TERMINAL BLOCK
F701,F801,F901	FUSE (T3, 15A/250V)	MF	FAN MOTOR	T801	TRANSFORMER
H	DEFROST HEATER(OPTION PARTS)	PTC64, PTC65	CIRCUIT PROTECTION	X63, X64, X66	REVERSING VALVE COIL RELAY
IC700,IC820,IC832	POWER MODULE	RT61	DEFROST THERMISTOR	21S4	DISCHARGE TEMP. THERMISTOR
IC802	POWER DEVICE	RT62	DISCHARGE TEMP. THERMISTOR	26H	FIN TEMP. THERMISTOR
LED	LED	RT64	EXPANSION VALVE COIL		AMBIENT TEMP. THERMISTOR
LEV	EXPANSION VALVE COIL	RT65	AMBIENT TEMP. THERMISTOR		

SUZ-KA15NAH2.MX

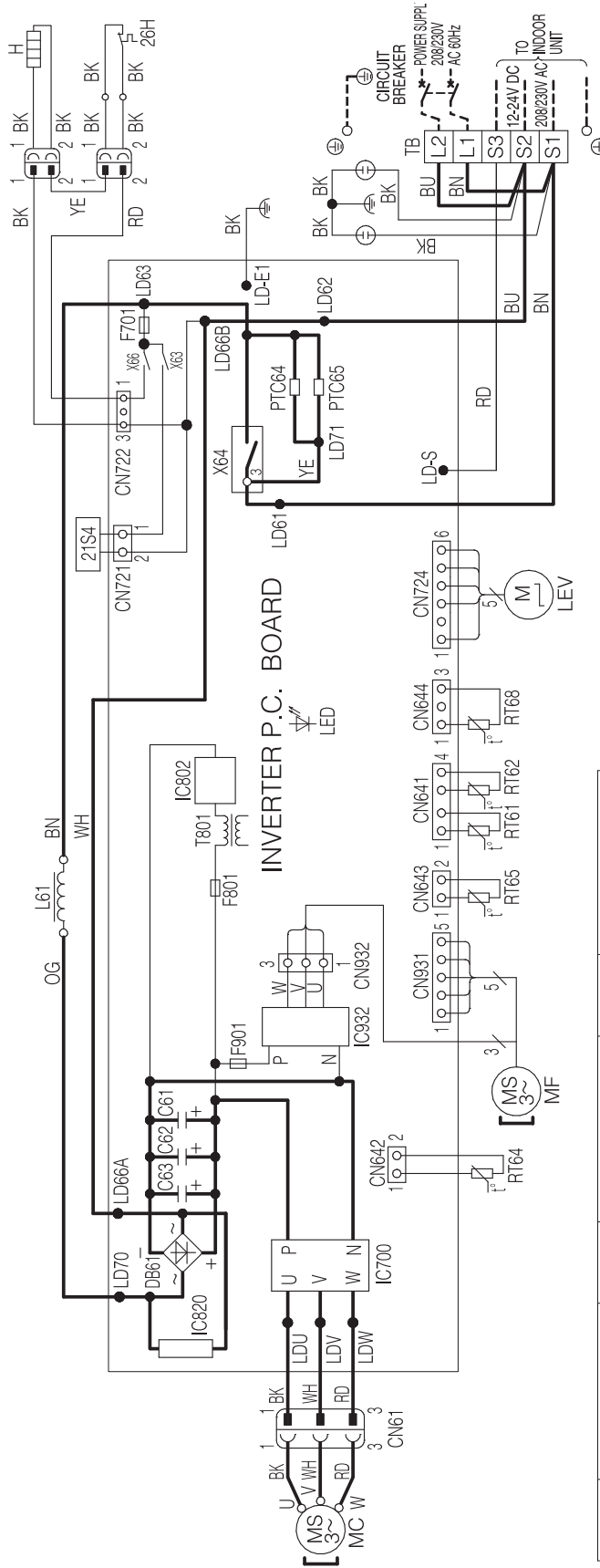

NOTES :

1. About the indoor side electric wiring, refer to the indoor unit electric wiring diagram for servicing.
2. Use copper supply wires.
3. Symbols indicate,  : Terminal block
 : Connector

SYMBOL	NAME	SYMBOL	NAME	SYMBOL	NAME
C61,C62,C63	SMOOTHING CAPACITOR	L61	REACTOR	RT68	OUTDOOR HEAT EXCHANGER TEMP. THERMISTOR
DB61	DIODE MODULE	MC	COMPRESSOR	TB	TERMINAL BLOCK
F701,F801,F801	FUSE (T3, 15AL250V)	MF	FAN MOTOR	T801	TRANSFORMER
H	DEFROST HEATER	PTC64, PTC65	CIRCUIT PROTECTION	RELAY	RELAY
IC700,IC820,IC832	POWER MODULE	RT61	DEFROST THERMISTOR	X63, X64, X66	REVERSING VALVE COIL
IC802	POWER DEVICE	RT62	DISCHARGE TEMP. THERMISTOR	21S4	HEATER PROTECTOR
LED	LED	RT64	FIN TEMP. THERMISTOR	26H	
LEV	EXPANSION VALVE COIL	RT65	AMBIENT TEMP. THERMISTOR		

6

REFRIGERANT SYSTEM DIAGRAM

SUZ-KA09NA(H)2.MX SUZ-KA12NA(H)2.MX SUZ-KA15NA(H)2.MX

Unit: Inch (mm)

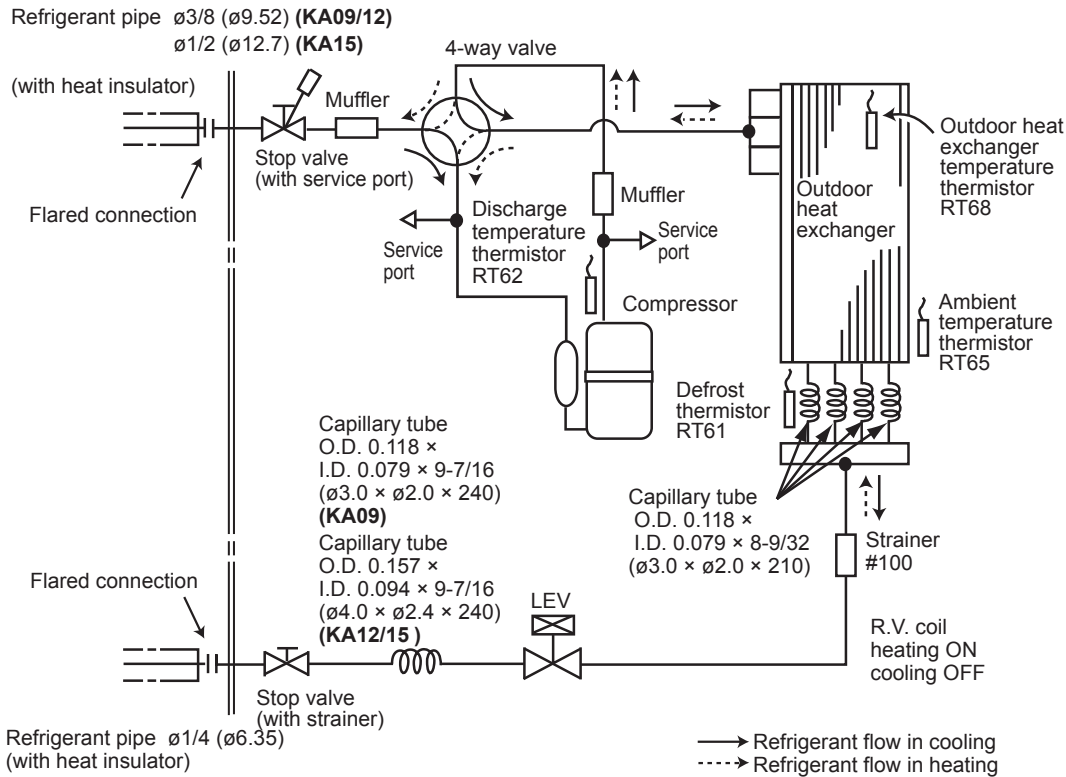

MAX. REFRIGERANT PIPING LENGTH and MAX. HEIGHT DIFFERENCE

Model	Refrigerant piping: ft		Piping size O.D: in	
	Max. Length A	Max. Height difference B	Gas	Liquid
SUZ-KA09/12/15NA(H)2	65	40	$3/8$ (KA09/12) $1/2$ (KA15)	$1/4$

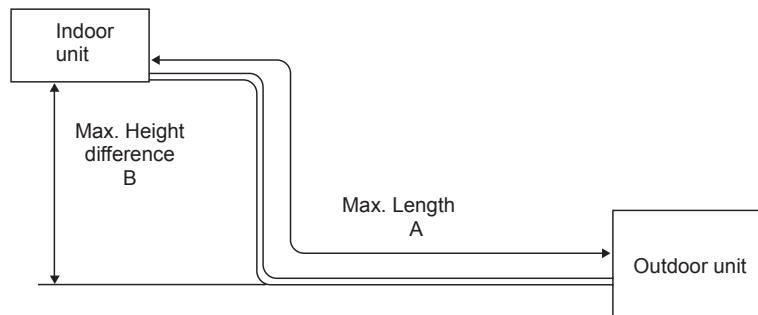

ADDITIONAL REFRIGERANT CHARGE (R410A: oz)

Refrigerant piping exceeding 25 ft requires additional refrigerant charge according to the calculation.

Model	Outdoor unit precharged	Refrigerant piping length (one way): ft					
		25	30	40	50	60	65
SUZ-KA09NA(H)2	2 lb 5 oz						
SUZ-KA12NA(H)2	2 lb 9 oz	0	1.08	2.16	3.24	4.32	5.4
SUZ-KA15NA(H)2	2 lb 9 oz						

Calculation: X oz = 1.08/5 oz / ft × (Refrigerant piping length (ft) - 25)

STANDARD OPERATION DATA

Representative matching			SEZ-KD09NA4		SEZ-KD12NA4		SEZ-KD15NA4		
Item		Unit	Cooling	Heating	Cooling	Heating	Cooling	Heating	
Total	Capacity	BTU/h	9000	12000	12000	15000	15000	18000	
	SHF	-	0.82	—	0.82	—	0.86	—	
	Input	kW	0.7	1.1	0.93	1.33	1.15	1.44	
Electrical circuit	Indoor unit		SEZ-KD09NA4		SEZ-KD12NA4		SEZ-KD15NA4		
	Power supply (V, phase, Hz)		230, 1, 60						
	Input	kW	0.06	0.04	0.07	0.05	0.09	0.07	
	Current	A	0.5	0.39	0.57	0.46	0.74	0.63	
	Outdoor unit		SUZ-KA09NA(H)2		SUZ-KA12NA(H)2		SUZ-KA15NA(H)2		
	Power supply (V, phase, Hz)		230, 1, 60						
	Input	kW	0.64	1.06	0.86	1.28	1.06	1.37	
	Current	A	2.89	4.64	3.47	5.29	4.24	5.63	
Refrigerant circuit	Condensing pressure	PSIG	358	473	387	441	415	386	
	Suction pressure	PSIG	133	110	147	99	141	99	
	Discharge temperature	°F	160	169	167	168	166	167	
	Condensing temperature	°F	109	114	114	124	119	114	
	Suction temperature	°F	63	36	66	31	55	31	
	Ref. pipe length	ft	25						
	Refrigerant charge (R410A)	-	1.05		1.15		1.15		
Indoor unit	Intake air temperature	DB	°F	80	70	80	70	80	70
		WB	°F	67	60	67	60	67	60
	Discharge air temperature	DB	°F	59	104	57	105	57	101
Outdoor unit	Intake air temperature	DB	°F	95	47	95	47	95	47
		WB	°F	75	43	75	43	75	43

Representative matching			SLZ-KF09NA		SLZ-KF12NA		SLZ-KF15NA		
Item		Unit	Cooling	Heating	Cooling	Heating	Cooling	Heating	
Total	Capacity	BTU/h	9000	11000	12000	13000	14100	18000	
	SHF	-	0.87	—	0.74	—	0.75	—	
	Input	kW	0.67	0.81	0.9	1.31	1.15	1.73	
Electrical circuit	Indoor unit		SLZ-KF09NA		SLZ-KF12NA		SLZ-KF15NA		
	Power supply (V, phase, Hz)		230, 1, 60						
	Input	kW	0.02	0.02	0.02	0.02	0.03	0.03	
	Current	A	0.2	0.15	0.24	0.19	0.32	0.27	
	Outdoor unit		SUZ-KA09NA(H)2		SUZ-KA12NA(H)2		SUZ-KA15NA(H)2		
	Power supply (V, phase, Hz)		230, 1, 60						
	Input	kW	0.65	0.79	0.88	1.29	1.12	1.7	
	Current	A	2.67	3.34	3.67	5.48	4.82	7.38	
Refrigerant circuit	Condensing pressure	PSIG	358	393	391	483	397	490	
	Suction pressure	PSIG	131	113	142	104	127	101	
	Discharge temperature	°F	159	167	167	159	168	191	
	Condensing temperature	°F	108	115	115	131	116	131	
	Suction temperature	°F	56	40	62	33	54	32	
	Ref. pipe length	ft	25						
	Refrigerant charge (R410A)	-	1.05		1.15		1.15		
Indoor unit	Intake air temperature	DB	°F	80	70	80	70	80	70
		WB	°F	67	60	67	60	67	60
	Discharge air temperature	DB	°F	57	103	56	105	57	112
Outdoor unit	Intake air temperature	DB	°F	95	47	95	47	95	47
		WB	°F	75	43	75	43	75	43

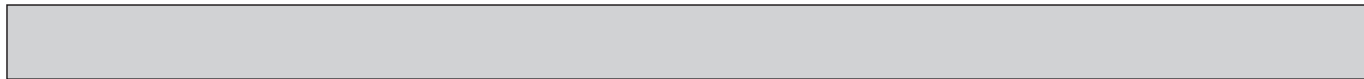

Representative matching			PEAD-A09AA7		PEAD-A12AA7		PEAD-A15AA7		
Item		Unit	Cooling	Heating	Cooling	Heating	Cooling	Heating	
Total	Capacity	BTU/h	9000	12000	12000	15000	15000	18000	
	SHF	-	0.9	—	0.9	—	0.9	—	
	Input	kW	0.72	0.9	0.93	1.16	1.15	1.35	
Electrical circuit	Indoor unit		PEAD-A09AA7		PEAD-A12AA7		PEAD-A15AA7		
	Power supply (V, phase, Hz)		230, 1, 60						
	Input	kW	0.07	0.05	0.09	0.07	0.11	0.09	
	Current	A	0.54	0.43	0.67	0.56	0.95	0.84	
	Outdoor unit		SUZ-KA09NA(H)2		SUZ-KA12NA(H)2		SUZ-KA15NA(H)2		
	Power supply (V, phase, Hz)		230, 1, 60						
	Input	kW	0.65	0.85	0.84	1.09	1.04	1.26	
	Current	A	2.55	3.48	3.36	4.45	4.01	5.01	
Refrigerant circuit	Condensing pressure	PSIG	358	380	383	374	412	343	
	Suction pressure	PSIG	133	111	153	93	144	97	
	Discharge temperature	°F	157	162	167	175	165	167	
	Condensing temperature	°F	108	113	113	111	119	105	
	Suction temperature	°F	57	38	49	40	57	38	
	Ref. pipe length	ft	25						
	Refrigerant charge (R410A)	-	1.05			1.15			
Indoor unit	Intake air temperature	DB	°F	80	70	80	70	80	70
		WB	°F	67	60	67	60	67	60
	Discharge air temperature	DB	°F	58	103	59	100	58	99
Outdoor unit	Intake air temperature	DB	°F	95	47	95	47	95	47
		WB	°F	75	43	75	43	75	43

Representative matching			SVZ-KP12NA		MLZ-KP09NA		MLZ-KP12NA		
Item		Unit	Cooling	Heating	Cooling	Heating	Cooling	Heating	
Total	Capacity	BTU/h	12000	11000	9000	12000	12000	15400	
	SHF	-	0.89	—	0.82	—	0.74	—	
	Input	kW	0.94	1.24	0.71	0.86	0.96	1.3	
Electrical circuit	Indoor unit		SVZ-KP12NA		MLZ-KP09NA		MLZ-KP12NA		
	Power supply (V, phase, Hz)		230, 1, 60		230, 1, 60				
	Input	kW	0.1		0.04				
	Current	A	0.9						
	Outdoor unit		SUZ-KA12NA(H)2		SUZ-KA09NA(H)2		SUZ-KA12NA(H)2		
	Power supply (V, phase, Hz)		230, 1, 60						
	Input	kW	0.84	1.11	0.67	0.82	0.92	1.26	
	Current	A	3.18	4.33	2.77	3.4	3.92	5.32	
Refrigerant circuit	Condensing pressure	PSIG	384	374	355	344	372	437	
	Suction pressure	PSIG	153	96	130	108	137	98	
	Discharge temperature	°F	167	170	158	162	165	172	
	Condensing temperature	°F	113	111	108	105	96	109	
	Suction temperature	°F	70	41	56	41	65	37	
	Ref. pipe length	ft	25		25				
	Refrigerant charge (R410A)	-	1.05		1.05		1.15		
Indoor unit	Intake air temperature	DB	°F	80	70	80	70	80	70
		WB	°F	67	60	67	60	67	60
	Discharge air temperature	DB	°F	59	100	57	104	57	111
Outdoor unit	Intake air temperature	DB	°F	95	47	95	47	95	47
		WB	°F	75	43	75	43	75	43

8-1. OUTDOOR FAN MOTOR CONTROL

The fan motor turns ON/OFF, interlocking with the compressor.

[ON] The fan motor turns ON 5 seconds before the compressor starts up.

[OFF] The fan motor turns OFF 15 seconds after the compressor has stopped running.

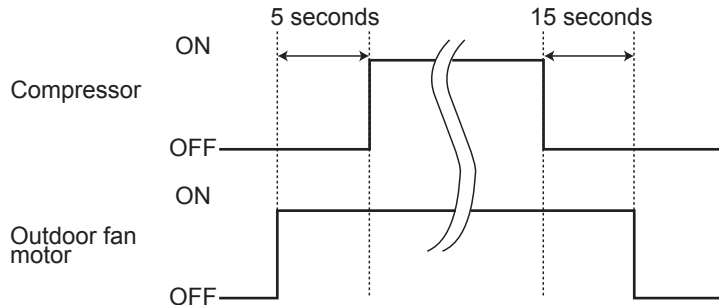

8-2. R.V. COIL CONTROL

Heating ON

Cooling OFF

Dry OFF

NOTE: The 4-way valve reverses for 5 seconds right before start-up of the compressor.

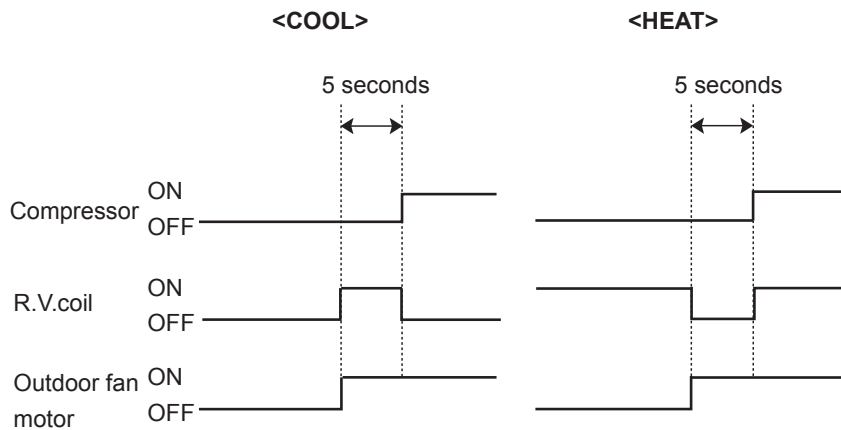

8-3. RELATION BETWEEN MAIN SENSOR AND ACTUATOR

Sensor	Purpose	Actuator					
		Compressor	LEV	Outdoor fan motor	R.V.coil	Indoor fan motor	Defrost heater *
Discharge temperature thermistor	Protection	○	○				
Indoor coil temperature thermistor	Cooling: Coil frost prevention	○					
	Heating: High pressure protection	○	○				
Defrost thermistor	Heating: Defrosting	○	○	○	○	○	
Fin temperature thermistor	Protection	○		○			
Ambient temperature thermistor	Cooling: Low ambient temperature operation	○	○	○			
	Heating: Defrosting (Heater)						○
Outdoor heat exchanger temperature thermistor	Cooling: Low ambient temperature operation	○	○	○			
	Cooling: High pressure protection	○	○	○			

*. SUZ-KA-NAH2 only.

9

SERVICE FUNCTION

9-1. CHANGE IN DEFROST SETTING

Changing defrost finish temperature

<JS> To change the defrost finish temperature, cut/solder the JS wire of the outdoor inverter P.C. board.
(Refer to "10-6. TEST POINT DIAGRAM AND VOLTAGE".)

Jumper		Defrost finish temperature
		SUZ-KA09/12/15
JS	Soldered (Initial setting)	41°F (5°C)
	None (Cut)	50°F (10°C)

9-2. PRE-HEAT CONTROL SETTING

When moisture gets into the refrigerant cycle, it may interfere the start-up of the compressor at low outside temperature. The pre-heat control prevents this interference. The pre-heat control turns ON when the discharge temperature is 68°F (20°C) or below. When the pre-heat control turns ON, the compressor is energized. (About 50 W)

Pre-heat control setting

<JK>

ON: To activate the pre-heat control, cut JK wire of the inverter P.C. board.

OFF: To deactivate the pre-heat control, solder JK wire of the inverter P.C. board.

(Refer to 10-6.1.)

Jumper		Pre-heat control setting
JK	Soldered	Deactivated (Factory setting)
	Cut	Activated

NOTE: When the inverter P.C. board is replaced, check the Jumper wires, and cut/solder them if necessary.

10

TROUBLESHOOTING

10-1. CAUTIONS ON TROUBLESHOOTING

1. Before troubleshooting, check the following

- 1) Check the power supply voltage.
- 2) Check the indoor/outdoor connecting wire for miswiring.

2. Take care of the following during servicing

- 1) Before servicing the air conditioner, be sure to turn OFF the main unit first with the remote controller, and turn off the breaker.
- 2) Be sure to turn OFF the power supply before removing the front panel, the cabinet, the top panel, and the electronic control P.C. board.
- 3) When removing the electrical parts, be careful of the residual voltage of smoothing capacitor.
- 4) When removing the electronic control P.C. board, hold the edge of the board with care NOT to apply stress on the components.
- 5) When connecting or disconnecting the connectors, hold the housing of the connector. DO NOT pull the lead wires.

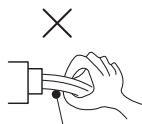

Lead wiring

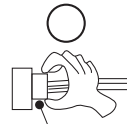

Housing point

3. Troubleshooting procedure

- 1) First, check if the OPERATION INDICATOR lamp is blinking ON and OFF to indicate an abnormality.
- 2) Before servicing check that the connector and terminal are connected properly.
- 3) When the electronic control P.C. board seems to be defective, check the copper foil pattern for disconnection and the components for bursting and discoloration.
- 4) Refer to "10-2. TROUBLESHOOTING CHECK TABLE" and "10-3. HOW TO PROCEED "SELF-DIAGNOSIS"". "

10-2. TROUBLE SHOOTING CHECK TABLE

SUZ-KA09NA(H)2.MX

SUZ-KA12NA(H)2.MX

SUZ-KA15NA(H)2.MX

No.	Symptoms	LED indication	check code	Abnormal point/ Condition	Condition	Remedy		
1	Outdoor unit does not operate.	1-time blink every 2.5 seconds	UP	Outdoor power system	Overcurrent protection cut-out operates 3 consecutive times within 1 minute after the compressor gets started.	•Reconnect connector of compressor. •Refer to "10-5.㉔How to check inverter/compressor". •Check stop valve.		
2			U3	Outdoor thermistors	Discharge temperature thermistor shorts, or opens during compressor running.	•Refer to "10-5.㉕ Check of outdoor thermistors".		
			U4		Fin temperature thermistor, defrost thermistor, P.C. board temperature thermistor, outdoor heat exchanger temperature thermistor or ambient temperature thermistor shorts, or opens during compressor running.			
3			FC	Outdoor control system	Nonvolatile memory data cannot be read properly.	•Replace inverter P.C. board.		
4	6-time blink 2.5 seconds OFF	E8 E9	Serial signal	The communication fails between the indoor and outdoor unit for 3 minutes.	•Check indoor/outdoor connecting wire. •Replace indoor or outdoor P.C. board if abnormality is displayed again.			
5	11-time blink 2.5 seconds OFF	UE	Stop valve/Closed valve	Closed valve is detected by compressor current.	•Check stop valve.			
6	16-time blink 2.5 seconds OFF	PL	Outdoor refrigerant system abnormality	A closed valve and air trapped in the refrigerant circuit are detected based on the temperature sensed by the indoor and outdoor thermistors and the current of the compressor.	•Check for a gas leak in a connecting piping, etc. •Check stop valve. •Refer to 10-5.㉖"Check of outdoor refrigerant circuit".			
7	'Outdoor unit stops and restarts 3 minutes later' is repeated.	2-time blink 2.5 seconds OFF		Overcurrent protection	Large current flows into intelligent power module.	•Reconnect connector of compressor. •Refer to "10-5.㉔How to check inverter/compressor". •Check stop valve.		
8				Discharge temperature overheat protection	Temperature of discharge temperature thermistor exceeds 116°C, compressor stops. Compressor can restart if discharge temperature thermistor reads 100°C or less 3 minutes later.	•Check refrigerant circuit and refrigerant amount. •Refer to "10-5.㉕Check of LEV".		
9				Fin temperature/P.C. board temperature thermistor overheat protection	Temperature of fin temperature thermistor on the heat sink exceeds 72 to 86°C or temperature of P.C. board temperature thermistor on the inverter P.C.board exceeds 72 to 85°C.	•Check around outdoor unit. •Check outdoor unit air passage. •Refer to "10-5.㉗Check of outdoor fan motor".		
10				High pressure protection	Indoor coil thermistor exceeds 70°C in HEAT mode. Defrost thermistor exceeds 70°C in COOL mode.	•Check refrigerant circuit and refrigerant amount. •Check stop valve.		
11				Compressor synchronous abnormality	The waveform of compressor current is distorted.	•Reconnect connector of compressor. •Refer to "10-5.㉔How to check inverter/compressor".		
12				Outdoor fan motor	Outdoor fan has stopped 3 times in a row within 30 seconds after outdoor fan start-up.	•Refer to "10-5.㉗Check of outdoor fan motor". •Refer to "10-5.㉕Check of inverter P.C. board".		
13				Each phase current of compressor	Each phase current of compressor cannot be detected normally.	•Refer to "10-5.㉕Check of inverter P.C. board".		
14				DC voltage	DC voltage of inverter cannot be detected normally.	•Refer to "10-5.㉔How to check inverter/compressor".		
15			Outdoor unit operates.	1-time blink 2.5 seconds OFF		Frequency drop by current protection	When the input current exceeds approximately 7A(KA09)/8A(KA12)/9A(KA15), compressor	The unit is normal, but check the following. •Check if indoor filters are clogged. •Check if refrigerant is short. •Check if indoor/outdoor unit air circulation is short cycled.
16						Frequency drop by high pressure protection	Temperature of indoor coil thermistor exceeds 131 °F [55 °C] in HEAT mode, compressor frequency lowers.	
		Frequency drop by defrosting in COOL mode			Indoor coil thermistor reads 46 °F [8 °C] or less in COOL mode, compressor frequency lowers.			
17		Frequency drop by discharge temperature protection			Temperature of discharge temperature thermistor exceeds 232 °F [111 °C], compressor frequency lowers.	•Check refrigerant circuit and refrigerant amount. •Refer to "10-5.㉕Check of LEV". •Refer to "10-5.㉕Check of outdoor thermistors".		
18		Low discharge temperature protection			Temperature of discharge temperature thermistor has been 122 °F [50 °C] or less for 20 minutes.	•Refer to "10-5.㉕Check of LEV". •Check refrigerant circuit and refrigerant amount.		
19	8-time blink 2.5 seconds OFF		PAM protection	The overcurrent flows into IGBT (Insulated Gate Biopolar transistor:TR821) or the bus-bar voltage reaches 320 V or more, PAM stops and restarts.	This is not malfunction. PAM protection will be activated in the following cases: 1. Instantaneous power voltage drop. (Short time power failure) 2. When the power supply voltage is high.			
			Zero cross detecting circuit	Zero cross signal for PAM control cannot be detected.				
20	9-time blink 2.5 seconds OFF		Inverter check mode	The connector of compressor is disconnected, inverter check mode starts.	•Check if the connector of the compressor is correctly connected. •Refer to "10-5.㉔How to check inverter/compressor".			

NOTE: 1. The location of LED is illustrated at the right figure. Refer to "10-6. TEST POINT DIAGRAM".
2. LED is lighted during normal operation.

The blinking frequency shows the number of times the LED blinks after every 2.5-second OFF.
(Example) When the blinking frequency is "2".

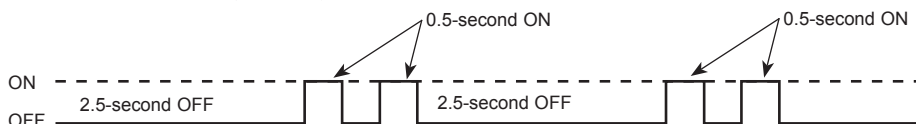

Inverter P.C. board

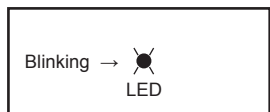

10-3. HOW TO PROCEED "SELF-DIAGNOSIS"

As this air conditioner has a function to memorize all the failures that had occurred, the latest failure detail can be recalled by following the procedure below. Use this function when the check code is not displayed with wired remote controller or the remote controller at use is wireless type.

10-3-1. Self-diagnosis <PAR-3xMAA ("x" represents 0 or later)>

① Select "Service" from the Main menu, and press the button.

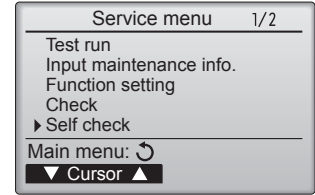

Select "Self check" with the **F1** or **F2** button, and press the button.

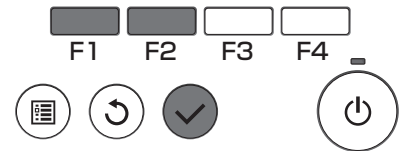

② With the **F1** or **F2** button, enter the refrigerant address, and press the button.

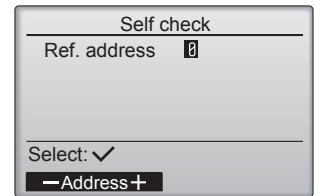

③ Check code, unit number, attribute will appear. "-" will appear if no error history is available.

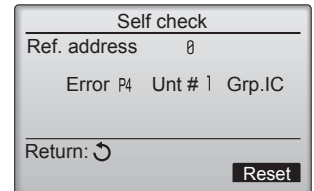

When there is no error history

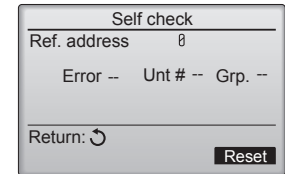

④ Resetting the error history.

Press the **F4** button (Reset) on the screen that shows the error history.



A confirmation screen will appear asking if you want to delete the error history.



Press the **F4** button (OK) to delete the error history.

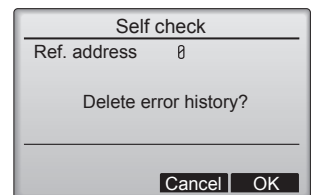

If deletion fails, "Request rejected" will appear.
"Unit not exist" will appear if no indoor units that are correspond to the entered address are found.

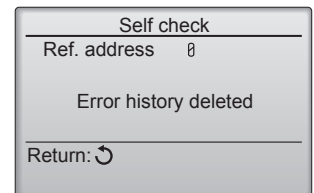

Navigating through the screens

- To go back to the Service menu button
- To return to the previous screen button

10-3-2. Self-diagnosis <Wireless remote controller>

<In case of trouble during operation>

When a malfunction occurs to air conditioner, both indoor unit and outdoor unit will stop and operation lamp blinks to inform unusual stop.

<Malfunction-diagnosis method at maintenance service>

[Procedure]

1. Press the CHECK button twice.
 - "CHECK" lights, and refrigerant address "00" blinks.
 - Check that the remote controller's display has stopped before continuing.
2. Press the temperature \odot \odot buttons.
 - Select the refrigerant address of the indoor unit for the self-diagnosis.
 - Note: Set refrigerant address using the outdoor unit's DIP switch (SW1).
(For more information, see the outdoor unit installation manual.)
3. Point the remote controller at the sensor on the indoor unit and press the HOUR button.
 - If an air conditioner error occurs, the indoor unit's sensor emits an intermittent buzzer sound, the operation light blinks, and the check code is output.
(It takes 3 seconds at most for check code to appear.)
4. Point the remote controller at the sensor on the indoor unit and press the ON/OFF button.
 - The check mode is cancelled.

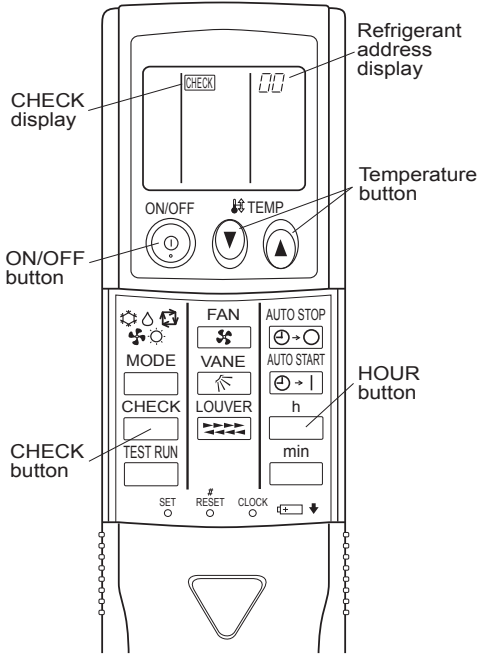

• Refer to the following tables for details on the check codes.

[Output pattern A]

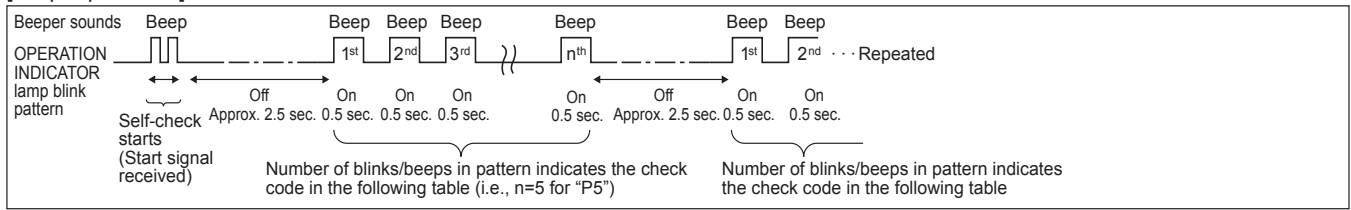

[Output pattern B]

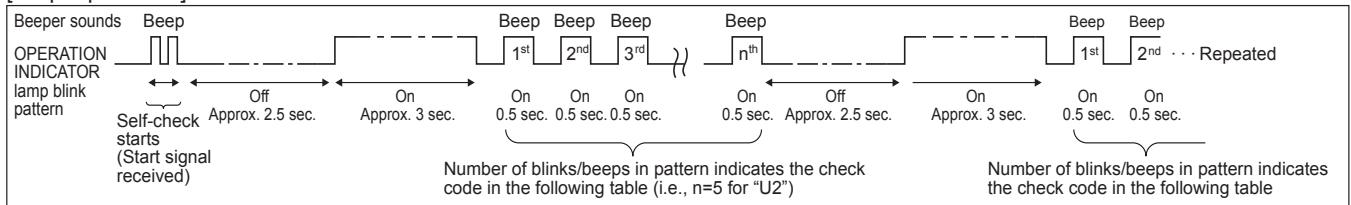

[Output pattern A] Errors detected by indoor unit

Wireless remote controller	Wired remote controller	Symptom	Remark
Beeper sounds/OPERATION INDICATOR lamp blinks (Number of times)	Check code		
1	P1	Intake sensor error	As for indoor unit, refer to indoor unit's service manual.
2	P2	Pipe (TH2) sensor error	
	P9	Pipe (TH5) sensor error	
3	E6,E7	Indoor/outdoor unit communication error	
4	P4	Drain sensor error/Float switch connector (CN4F) open	
5	P5	Drain pump error	
	PA	Forced compressor stop (due to water leakage abnormality)	
6	P6	Freezing/Overheating protection operation	
7	EE	Communication error between indoor and outdoor units	
9	E4,E5	Remote controller signal receiving error	
12	Fb (FB)*	Indoor unit control system error (memory error, etc.)	
14	PL	Abnormality of refrigerant circuit	
-	E0,E3	Remote controller transmission error	
-	E1,E2	Remote controller control board error	

[Output pattern B] Errors detected by unit other than indoor unit (outdoor unit, etc.)

Wireless remote controller	Wired remote controller	Symptom
Beeper sounds/OPERATION INDICATOR lamp blinks (Number of times)	Check code	
1	E9	Indoor/outdoor unit communication error (Transmitting error) (Outdoor unit)
2	UP	Compressor overcurrent interruption
3	U3,U4	Open/short of outdoor unit thermistors
14	Others	Other errors (Refer to the technical manual for the outdoor unit.)

- Notes: 1. If the beeper does not sound again after the initial 2 beeps to confirm the self-check start signal was received and the OPERATION INDICATOR lamp does not come on, there are no error records.
 2. If the beeper sounds 3 times continuously "beep, beep, beep (0.4 + 0.4 + 0.4 sec.)" after the initial 2 beeps to confirm the self-check start signal was received, the specified refrigerant address is incorrect.

*The check code in the parenthesis indicates PAR-3xMAA model. ("x" represents 0 or later).

10-4. TROUBLE CRITERION OF MAIN PARTS

SUZ-KA09NA(H)2.MX SUZ-KA12NA(H)2.MX SUZ-KA15NA(H)2.MX

Part name	Check method and criterion	Figure													
Defrost thermistor (RT61) Fin temperature thermistor (RT64) Ambient temperature thermistor (RT65) Outdoor heat exchanger temperature thermistor (RT68)	Measure the resistance with a tester. Refer to "Inverter P.C. board" in "10-6. TEST POINT DIAGRAM AND VOLTAGE", for the chart of thermistor.														
Discharge temperature thermistor (RT62)	Measure the resistance with a tester. Before measurement, hold the thermistor with your hands to warm it up. Refer to "Inverter P.C. board" in "10-6. TEST POINT DIAGRAM AND VOLTAGE", for the chart of thermistor.														
Compressor	Measure the resistance between terminals with a tester. (Temperature: 14 - 104 °F (-10 - 40 °C)) <table border="1" style="margin-left: 20px;"> <thead> <tr> <th rowspan="2"></th> <th colspan="3">Normal (Ω)</th> </tr> <tr> <th>KA09</th> <th>KA12</th> <th>KA15</th> </tr> </thead> <tbody> <tr> <td>U-V</td> <td rowspan="3">1.26 - 1.72</td> <td rowspan="3">1.60 - 2.17</td> <td rowspan="3">0.82 - 1.11</td> </tr> <tr> <td>U-W</td> </tr> <tr> <td>V-W</td> </tr> </tbody> </table>		Normal (Ω)			KA09	KA12	KA15	U-V	1.26 - 1.72	1.60 - 2.17	0.82 - 1.11	U-W	V-W	
	Normal (Ω)														
	KA09	KA12	KA15												
U-V	1.26 - 1.72	1.60 - 2.17	0.82 - 1.11												
U-W															
V-W															
Outdoor fan motor	Measure the resistance between lead wires with a tester. (Temperature: 14 ~ 104 °F (-10 ~ 40 °C)) <table border="1" style="margin-left: 20px;"> <thead> <tr> <th rowspan="2">Color of lead wire</th> <th>Normal (Ω)</th> </tr> <tr> <th>KA09/12/15</th> </tr> </thead> <tbody> <tr> <td>RD - BK BK - WH WH - RD</td> <td>29 - 40</td> </tr> </tbody> </table>	Color of lead wire	Normal (Ω)	KA09/12/15	RD - BK BK - WH WH - RD	29 - 40									
Color of lead wire	Normal (Ω)														
	KA09/12/15														
RD - BK BK - WH WH - RD	29 - 40														
R. V. coil (21S4)	Measure the resistance using a tester. [Temperature: 14 - 104°F (-10 - 40°C)] <table border="1" style="margin-left: 20px;"> <thead> <tr> <th>Normal (kΩ)</th> </tr> </thead> <tbody> <tr> <td>0.97 - 1.38</td> </tr> </tbody> </table>	Normal (kΩ)	0.97 - 1.38												
Normal (kΩ)															
0.97 - 1.38															
Expansion valve coil (LEV)	Measure the resistance using a tester. [Temperature: 14 - 104°F (-10 - 40°C)] <table border="1" style="margin-left: 20px;"> <thead> <tr> <th>Color of lead wire</th> <th>Normal (Ω)</th> </tr> </thead> <tbody> <tr> <td>RD - OG</td> <td rowspan="5">37 - 54</td> </tr> <tr> <td>RD - WH</td> </tr> <tr> <td>RD - BU</td> </tr> <tr> <td>RD - YE</td> </tr> <tr> <td>RD - YE</td> </tr> </tbody> </table>	Color of lead wire	Normal (Ω)	RD - OG	37 - 54	RD - WH	RD - BU	RD - YE	RD - YE						
Color of lead wire	Normal (Ω)														
RD - OG	37 - 54														
RD - WH															
RD - BU															
RD - YE															
RD - YE															
Defrost heater (SUZ-KA·NAH2)	Measure the resistance using a tester. [Temperature: 14 - 104°F (-10 - 40°C)] <table border="1" style="margin-left: 20px;"> <thead> <tr> <th>Normal (Ω)</th> </tr> </thead> <tbody> <tr> <td>349 - 428</td> </tr> </tbody> </table>	Normal (Ω)	349 - 428												
Normal (Ω)															
349 - 428															

10-5. TROUBLESHOOTING FLOW

A How to check inverter/compressor

Disconnect the connector (CN61) between compressor and the intelligent power module (IPM).

Check the voltage between terminals.

.....See 10-5.ⓑ “Check of open phase”.

Are the voltages balanced?

No

Replace the inverter P.C. board.

Yes

Check the compressor.

.....See 10-5.ⓒ “Check of compressor”.

B Check of open phase

- With the connector between the compressor and the intelligent power module disconnected, activate the inverter and check if the inverter is normal by measuring the voltage balance between the terminals.

Output voltage is 50 - 130 V. (The voltage may differ according to the tester.)

< Operation method (Test run operation)>

1. Press the TEST (RUN) button twice.
2. Press the MODE button and switch to the COOL (or HEAT) mode.
3. Compressor starts at rated frequency in COOL mode or 58 Hz in HEAT mode.
4. Indoor fan operates at High speed.
5. To cancel test run operation, press the ON/OFF button on remote controller.

<Measurement point>

at 3 points

BK (U) - WH (V)

BK (U) - RD (W)

WH(V) - RD (W)

Measure AC voltage between the lead wires at 3 points.

NOTE: 1. Output voltage varies according to power supply voltage.

2. Measure the voltage by analog type tester.

3. During this check, LED of the inverter P.C. board blinks 9 times.

(Refer to "10-6. TEST POINT DIAGRAM AND VOLTAGE".)

C Check of compressor

Refer to 10-5.ⓒ “Check of compressor winding”.

Is the compressor normal?

No

Replace the compressor.

Yes

Refer to 10-5.ⓔ “Check of compressor operation time”.

Does the compressor operate continuously?

No

Refer to 10-5.ⓕ “Check of compressor start failure”.

Yes

OK.

D Check of compressor winding

- Disconnect the connector between the compressor and intelligent power module, and measure the resistance between the compressor terminals.

<Measurement point>

Measure the resistance between the lead wires at 3 points.

BK - WH

BK - RD

WH - RD

<Judgement>

Refer to "10-4. TROUBLE CRITERION OF MAIN PARTS".

0[Ω] Abnormal [short]

Infinite [Ω] Abnormal [open]

NOTE: Be sure to zero the ohmmeter before measurement.

E Check of compressor operation time

- Connect the compressor and activate the inverter. Then measure the time until the inverter stops due to over current.

<Operation method>

Start heating or cooling operation by pressing the TEST button

twice on the remote controller. (Test run mode)

(TEST RUN OPERATION: Refer to 10-5 ⑥.)

<Measurement>

Measure the time from the start of compressor to the stop of compressor due to overcurrent.

<Judgement>

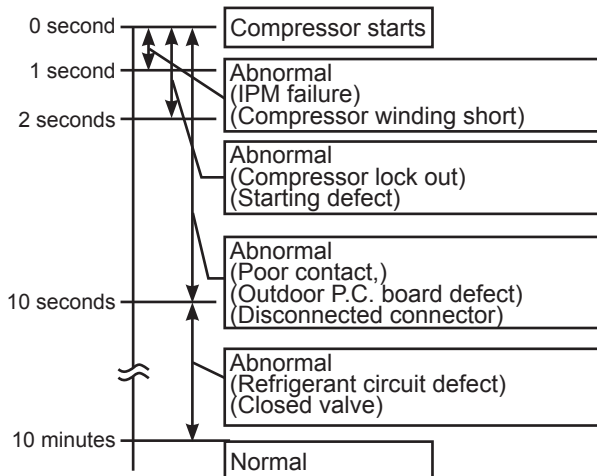

F Check of compressor start failure

Confirm that 1~4 is normal.

- Electrical circuit check

1. Contact of the compressor connector

2. Output voltage of inverter P.C. board and balance of them (See 10-5.⑥)

3. Direct current voltage between DB61(+) and (-) on the inverter P.C. board

4. Voltage between outdoor terminal block S1-S2

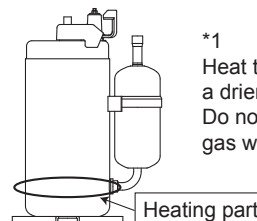
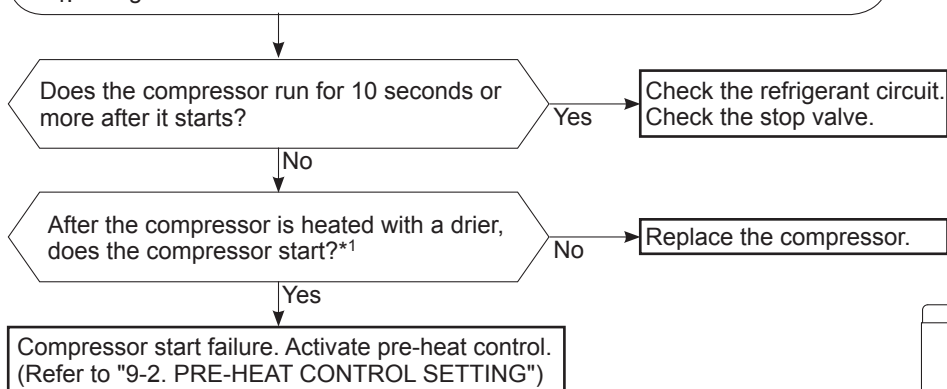

*1

Heat the compressor with a drier for about 20 minutes. Do not recover refrigerant gas while heating.

G Check of outdoor thermistors

Disconnect the connector of thermistor in the outdoor P.C. board (see below table), and measure the resistance of thermistor.

Is the resistance of thermistor normal?
(Refer to "10-6. TEST POINT DIAGRAM AND VOLTAGE".)

No → Replace the thermistor except RT64. When RT64 is abnormal, replace the inverter P.C. board.

Yes

Reconnect the connector of thermistor.
Turn ON the power supply and press EMERGENCY OPERATION switch.

Does the unit operate for 10 minutes or more without showing thermistor abnormality?

No → Replace the inverter P.C. board.

Yes

OK.
(Cause is poor contact.)

Thermistor	Symbol	Connector, Pin No.	Board
Defrost	RT61	Between CN641 pin1 and pin2	Inverter P.C. board
Discharge temperature	RT62	Between CN641 pin3 and pin4	
Fin temperature	RT64	Between CN642 pin1 and pin2	
Ambient temperature	RT65	Between CN643 pin1 and pin2	
Outdoor heat exchanger temperature	RT68	Between CN644 pin1 and pin3	

H Check of R.V. coil

First of all, measure the resistance of R.V. coil to check if the coil is defective. Refer to "10-4. TROUBLE CRITERION OF MAIN PARTS".

In case CN721 is disconnected or R.V. coil is open, voltage is generated between the terminal pins of the connector although no signal is being transmitted to R.V. coil. Check if CN721 is connected.

Unit operates in COOL mode even if it is set to HEAT mode.

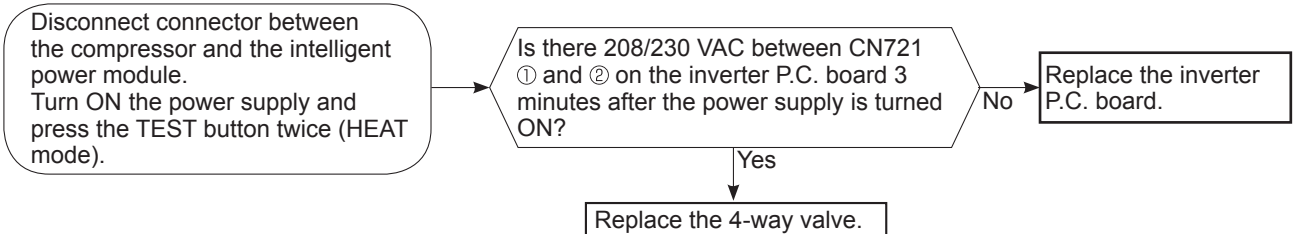

Unit operates in HEAT mode even if it is set to COOL mode.

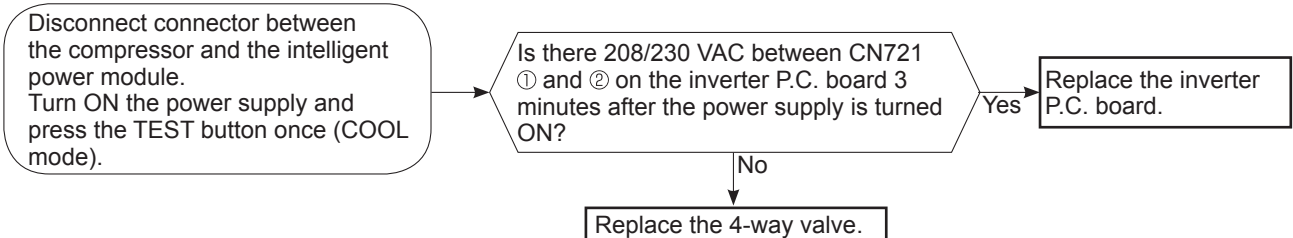

① Check of outdoor fan motor

Check the connection between the connector CN931 and CN932. Disconnect the connectors CN931 and CN932 from the inverter P.C. board.

Is the resistance between each terminal of outdoor fan motor normal? (Refer to 10-4.)

Yes

Disconnect CN932 from the inverter P.C. board, and turn on the power supply.

Rotate the outdoor fan motor manually and measure the voltage of CN931.
Between 1(+) and 5(-)
Between 2(+) and 5(-)
Between 3(+) and 5(-)

Does the voltage between each terminal become 5 and 0 VDC repeatedly?

No

(Fixed to either 5 or 0 VDC)

Yes

Does the outdoor fan motor rotate smoothly?

No

Yes

Replace the outdoor fan motor.

Replace the inverter P.C. board.

J Check of power supply

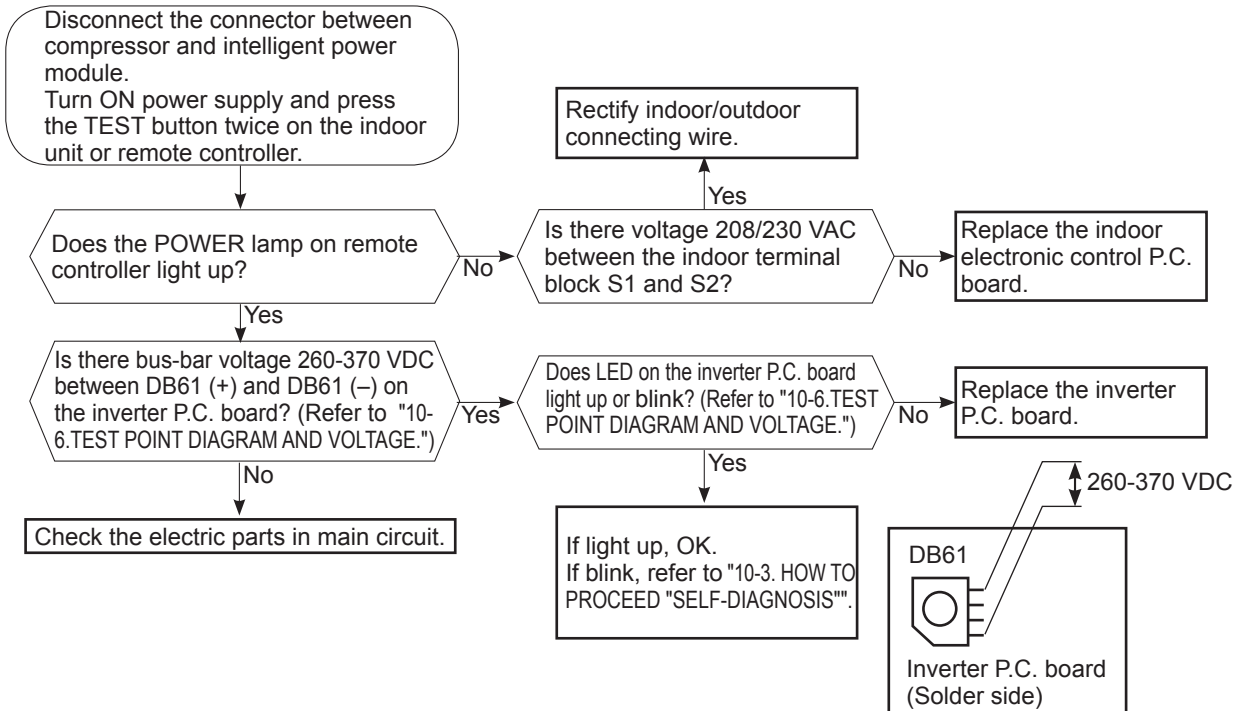

K Check of LEV (Expansion valve)

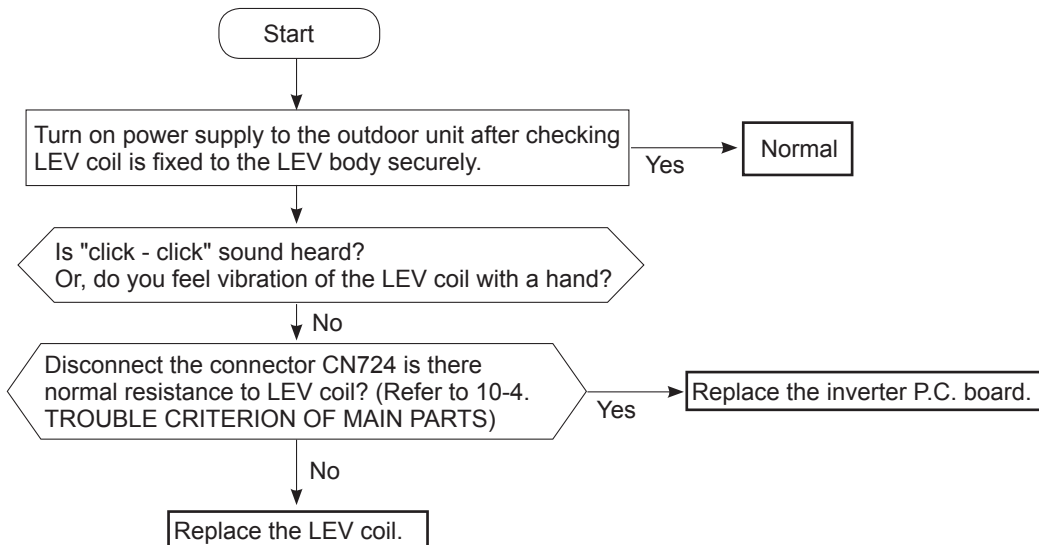

Ⓛ Check of inverter P.C. board

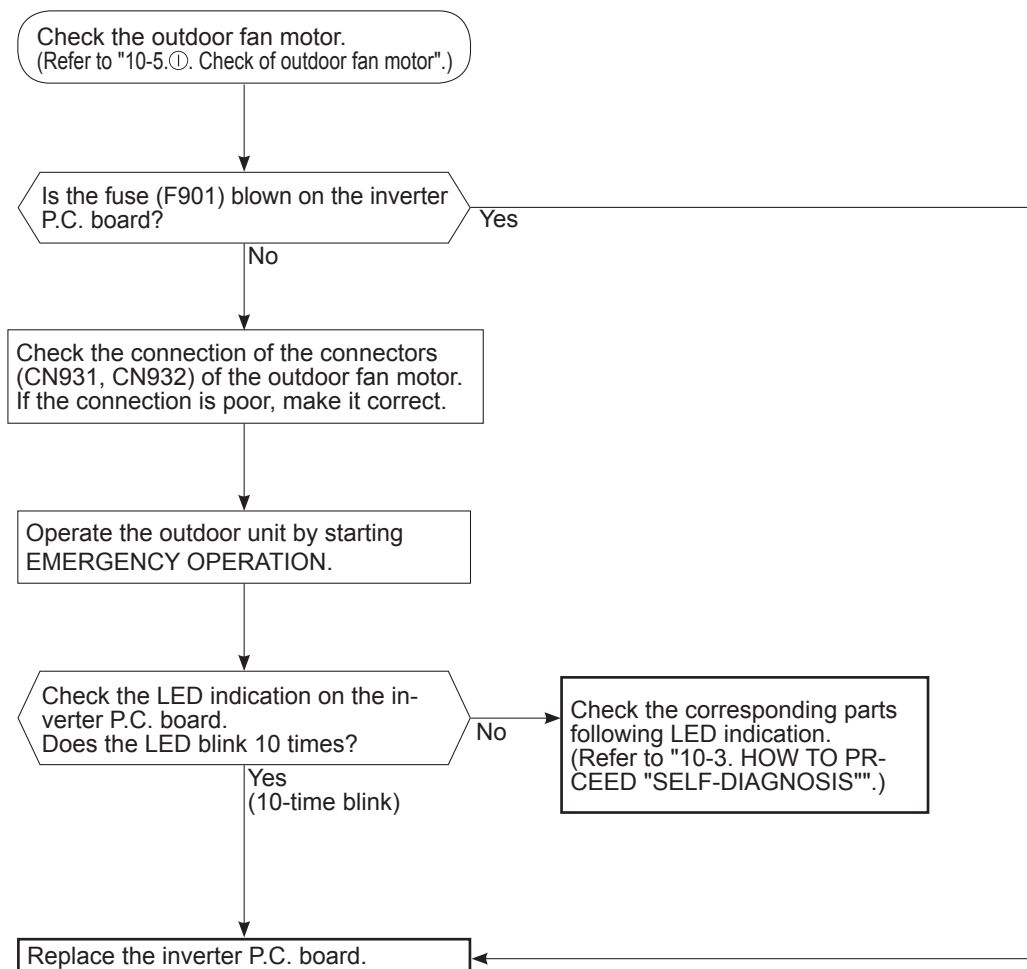

M How to check miswiring and serial signal error

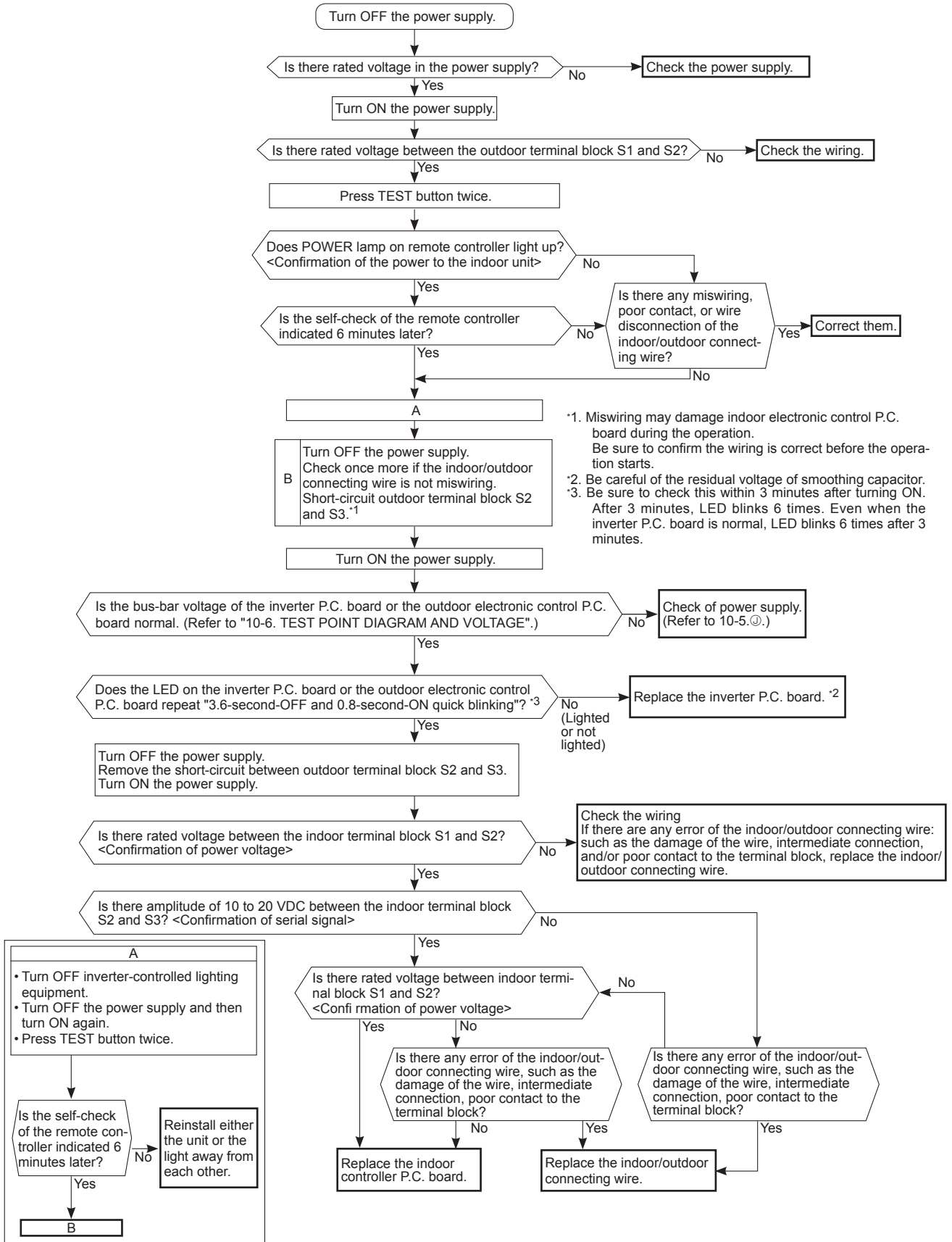

Ⓝ Check the defrost heater

SUZ-KA09/12/15NAH2

Check the following points before checking electric continuity.

1. Does the resistance of ambient temperature thermistor have the characteristics? Refer to 10-6.1.
2. Is the resistance of defrost heater normal? Refer to 10-4.
3. Is the heater protector closed?
4. Are both ambient temperature thermistor and circuit of defrost heater securely connected to connectors?

In HEAT mode, for more than 5 minutes, let the ambient temperature thermistor continue to read 32°F (0°C) or below, and let the defrost thermistor continue to read 30°F (-1°C) or below.

NOTE: In case both thermistors are more than the above temperature, cool them with cold water etc...

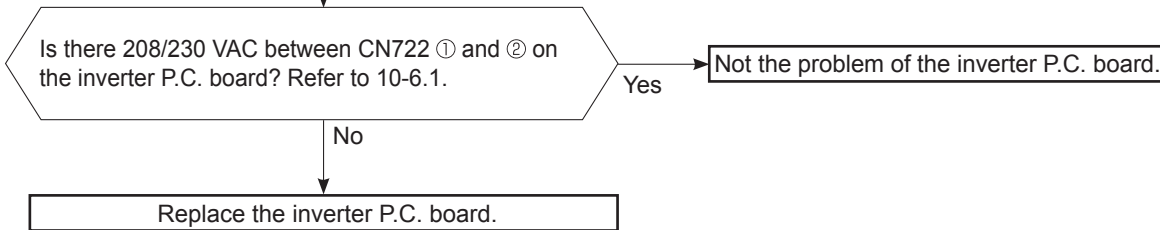

Ⓞ Check of outdoor refrigerant circuit

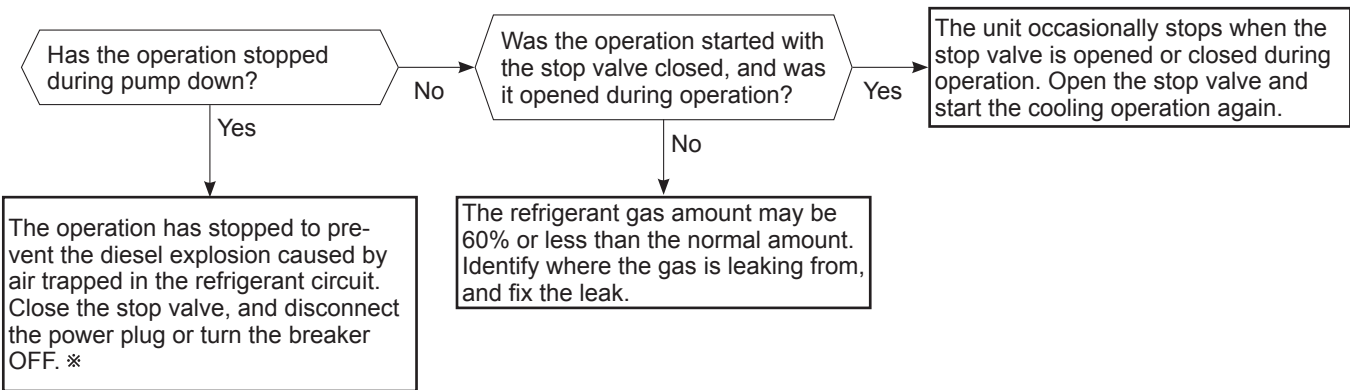

* **CAUTION** : Do not start the operation again to prevent hazards.

P Electromagnetic noise enters into TV sets or radios

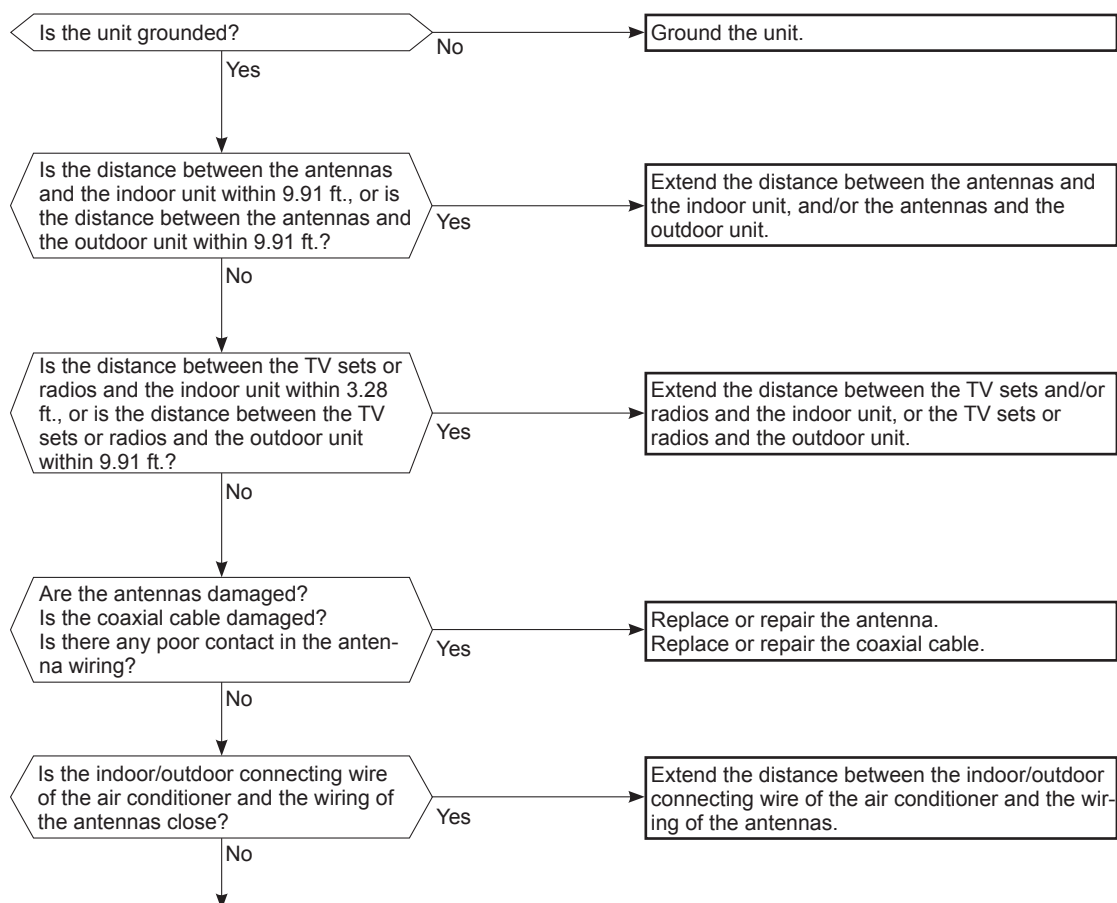

Even if all of the above conditions are fulfilled, the electromagnetic noise may enter, depending on the electric field strength or the installation condition (combination of specific conditions such as antennas or wiring).
Check the followings before asking for service.

1. Devices affected by the electromagnetic noise
TV sets, radios (FM/AM broadcast, shortwave)
2. Channel, frequency, broadcast station affected by the electromagnetic noise
3. Channel, frequency, broadcast station unaffected by the electromagnetic noise
4. Layout of:
indoor/outdoor unit of the air conditioner, indoor/outdoor wiring, grounding wire, antennas, wiring from antennas, receiver
5. Electric field intensity of the broadcast station affected by the electromagnetic noise
6. Presence or absence of amplifier such as booster
7. Operation condition of air conditioner when the electromagnetic noise enters in
 - 1) Turn OFF the power supply once, and then turn ON the power supply. In this situation, check for the electromagnetic noise.
 - 2) Within 3 minutes after turning ON the power supply, press OPERATE/STOP (ON/OFF) button on the remote controller for power ON, and check for the electromagnetic noise.
 - 3) After a short time (3 minutes later after turning ON), the outdoor unit starts running. During operation, check for the electromagnetic noise.
 - 4) Press OPERATE/STOP (ON/OFF) button on the remote controller for power OFF, when the outdoor unit stops but the indoor/outdoor communication still runs on. In this situation, check for the electromagnetic noise.

10-6. TEST POINT DIAGRAM AND VOLTAGE

Inverter P.C. board

SUZ-KA09NA(H)2.MX SUZ-KA12NA(H)2.MX SUZ-KA15NA(H)2.MX

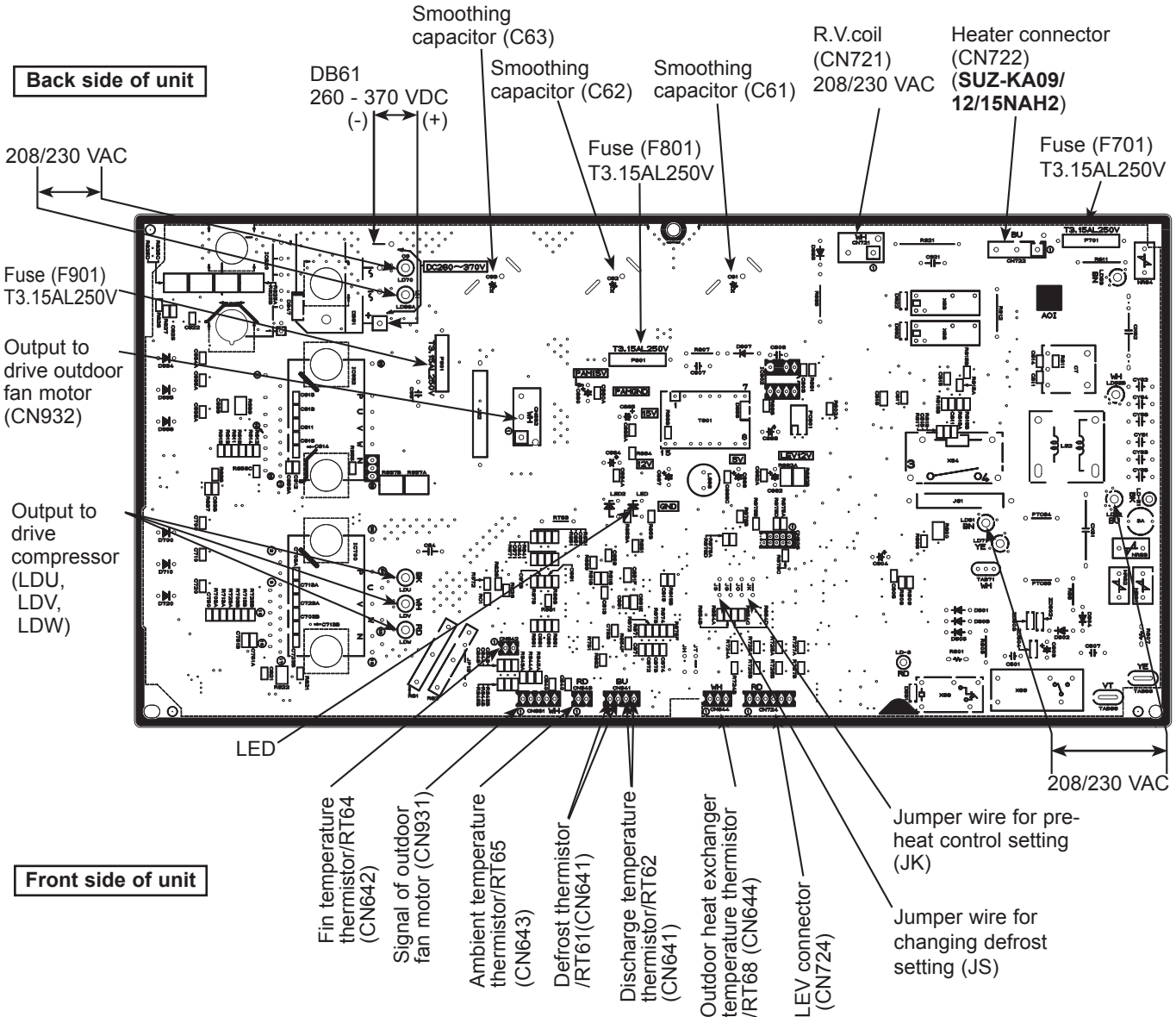

Defrost thermistor(RT61)
Ambient temperature thermistor(RT65)
Outdoor heat exchanger temperature thermistor(RT68)

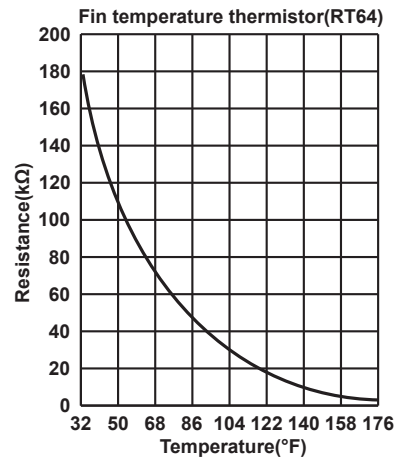
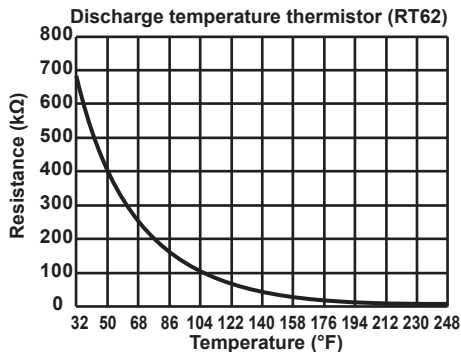
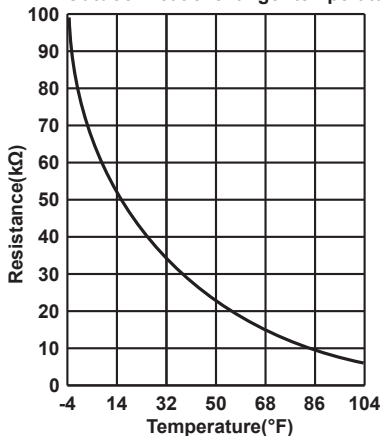

11-1. UNIT FUNCTION SETTING BY THE REMOTE CONTROLLER

Each function can be set according to necessity using the remote controller. The setting of function for each unit can only be done by the remote controller. Select function available from the table 1.

<Table 1> Function selections

(1) Functions available when setting the unit number to 00 (Select 00 referring to ④ setting the indoor unit number.)

Function	Settings	Mode No.	Setting No.	● : Initial setting (when sent from the factory)	Check	Remarks
		Wired remote controller (RF thermostat)				
Power failure automatic recovery	Not available	01	1			The setting is applied to all the units in the same refrigerant system.
	Available (Approx. 4-minute wait-period after power is restored.)	(101)	2	●		
Indoor temperature detecting	Indoor unit's internal sensor	02	1	●		
	Data from main remote controller *1	(—)	2			
		3				
LOSSNAY connectivity	Not supported	03	1	●		
	Supported (indoor unit dose not intake outdoor air through LOSSNAY)	(103)	2			
	Supported (indoor unit intakes outdoor air through LOSSNAY)		3			
Power supply voltage	230V	04	1	●		
	208V	(104)	2			
Frost prevention temperature	2°C [36°F] (Normal)	15	1	●		
	3°C [37°F]	(115)	2			

*1 Can be set only when a wired remote controller is used.

When using 2 remote controllers (2-remote controller operation), the remote controller with built-in sensor must be set as a main remote controller.

(2) Functions are available when setting the unit number to 01.

Function	Settings	Mode No. Wired remote controller (RF thermostat)	Setting No.	● : Initial setting (Factory setting)				Check
				Ceiling concealed	Ceiling cassette	Ceiling suspended	Multi position	
				SEZ-KD-NA4	SLZ-KA-NA	PEAD-A-AA	SVZ-KP-NA	
Filter sign	100h	07 (107)	1					
	2500h		2		●			
	No filter sign indicator		3	●		●	●	
External static pressure	5/15/35/50Pa (0.02/0.06/0.14/0.20in.WG)	08 (108)	Refer to the table below	—	Refer to the table below	Refer to the table below		
		10 (110)	Refer to the table below	—	Refer to the table below	Refer to the table below		
Heater control *2	No heater present	11 (111)	1	—	—	●	●	
	Heater present		2	—	—			
	SEZ, SLZ :Set temp -4.5°F ON PEAD, SVZ :Heater not operation in Defrost/Error	23 (123)	1	●	●	●	●	
	SEZ, SLZ :Set temp -1.8°F ON PEAD, SVZ :Heater not operation in Defrost/Error*4		2					
Set temperature in heating mode *3	Available	24 (124)	1	●	●	●	●	
	Not available		2					
Fan speed during the heating thermo OFF	Extra low	25 (125)	1	●	●	●	●	
	Stop		2					
	Set fan speed		3					
Fan speed during the cooling thermo OFF	Set fan speed	27 (127)	1	●	●	●	●	
	Stop		2					
Detection of abnormality of the pipe temperature (P8)	Available	28	1	●	●	●	●	
	Not available	(128)	2			●	●	

*2 For the detail of Heater control, refer to the service manual.

*3 4 degC (7.2 degF) up

*4 Depend on the error, heater may not operate please refer to SVZ service manual.

External static pressure setting for SEZ.

External static pressure	Setting No.		● : Initial setting (Factory setting)	Check
	Mode No. 08	Mode No. 10		
5Pa (0.02in.WG)	1	2		
15Pa (0.06in.WG)	1	1	●	
35Pa (0.14in.WG)	2	1		
50Pa (0.20in.WG)	3	1		

External static pressure setting for PEAD.

External static pressure	Setting No.		● : Initial setting (Factory setting)	Check
	Mode No. 08	Mode No. 10		
35Pa (0.14in.WG)	2	1		
50Pa (0.20in.WG)	3	1	●	
70Pa (0.28in.WG)	1	2		
100Pa (0.40in.WG)	2	2		
150Pa (0.60in.WG)	3	2		

External static pressure setting for SVZ (Vertical, Horizontal left, Horizontal right position*).

External static pressure	Setting No.		● : Initial setting (Factory setting)	Check
	Mode No. 08	Mode No. 10		
75Pa (0.3in.WG)	1	1		
125Pa (0.5in.WG)	2	1	●	
200Pa (0.8in.WG)	3	1		

* Regarding to down flow setting, please refer to down flow kit installation manual.

11-1-1. Selecting functions using the wired remote controller <PAR-3xMAA ("x" represents 0 or later)>

<Service menu>

Maintenance password is required

① Select "Service" from the Main menu, and press the  button.

*At the main display, the menu button and select "Service" to make the maintenance setting.

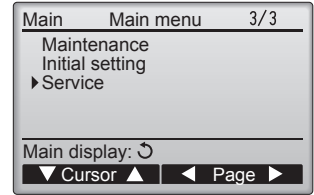

② When the Service menu is selected, a window will appear asking for the password.

To enter the current maintenance password (4 numerical digits), move the cursor to the digit you want to change with the **F1** or **F2** button.



Set each number (0 through 9) with the **F3** or **F4** button.



Then, press the  button.

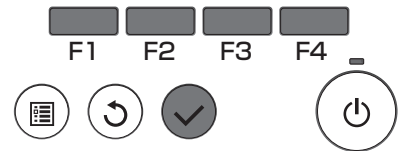
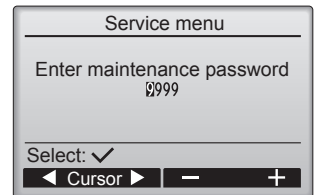

Note: The initial maintenance password is "9999". Change the default password as necessary to prevent unauthorized access. Have the password available for those who need it.

: If you forget your maintenance password, you can initialize the password to the default password "9999" by pressing and holding the **F1 and **F2** buttons simultaneously for three seconds on the maintenance password setting screen.**

③ If the password matches, the Service menu will appear.

The type of menu that appears depends on the connected indoor units' type.

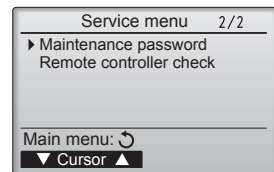
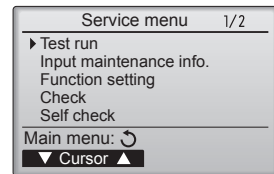



Note: Air conditioning units may need to be stopped to make certain settings. There may be some settings that cannot be made when the system is centrally controlled.



A screen will appear that indicates the setting has been saved.



Navigating through the screens

- To go back to the Main menu  button
- To return to the previous screen.....  button

<Function setting>

- ① Select "Service" from the Main menu, and press the button.



- Select "Function setting" with the **F1** or **F2** button, and press the button.

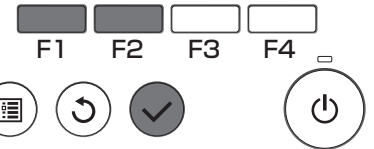
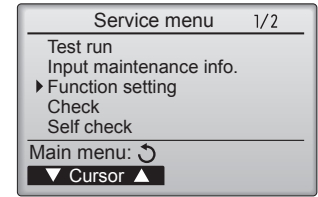

- ② Set the indoor unit refrigerant addresses and unit numbers with the **F1** through **F4** buttons, and then press the button to confirm the current setting.

<Checking the indoor unit No.>

When the button is pressed, the target indoor unit will start fan operation. If the unit is common or when running all units, all indoor units for the selected refrigerant address will start fan operation.

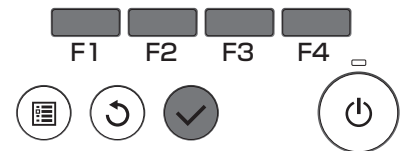
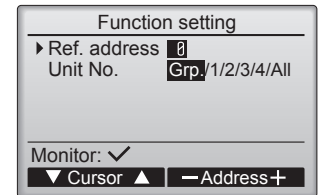

- ③ When data collection from the indoor units is completed, the current settings appears highlighted. Non-highlighted items indicate that no function settings are made. Screen appearance varies depending on the "Unit No." setting.

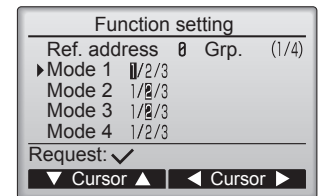

- ④ Use the **F1** or **F2** button to move the cursor to select the mode number, and change the setting number with the **F3** or **F4** button.

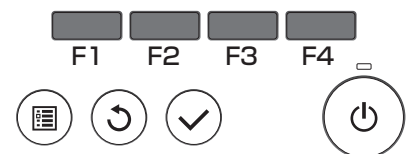
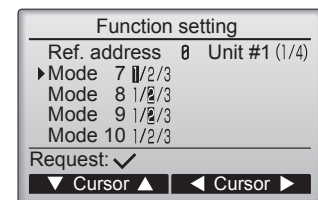

- ⑤ When the settings are completed, press the button to send the setting data from the remote controller to the indoor units. When the transmission is successfully completed, the screen will return to the Function setting screen.

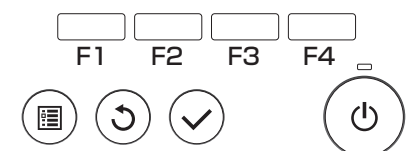
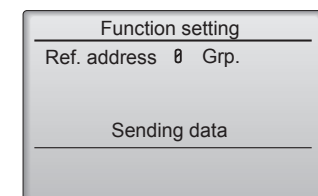

Note:

- Make the above settings only on Mr. Slim units as necessary.
- The above function settings are not available for the CITY MULTI units.
- Table 1 summarizes the setting options for each mode number. Refer to the indoor unit Installation Manual for the detailed information about initial settings, mode numbers, and setting numbers for the indoor units.
- Be sure to write down the settings for all functions if any of the initial settings has been changed after the completion of installation work.

<"Terminal with locking mechanism" Detaching points>

The terminal which has the locking mechanism can be detached as shown below.
 There are two types (refer to (1) and (2)) of the terminal with locking mechanism.
 The terminal without locking mechanism can be detached by pulling it out.
 Check the shape of the terminal before detaching.

(1) Slide the sleeve and check if there is a locking lever or not.

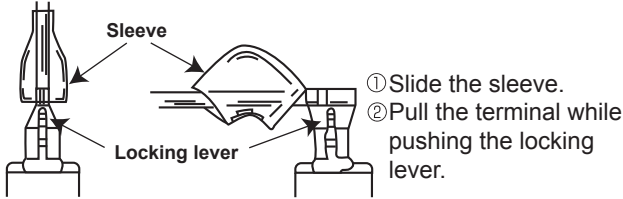

(2) The terminal with this connector has the locking mechanism.

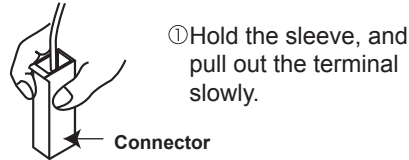

12-1. SUZ-KA09NA(H)2.MX SUZ-KA12NA(H)2.MX SUZ-KA15NA(H)2.MX

—————> : Indicates the visible parts in the photos/figures.
 - - - - -> : Indicates the invisible parts in the photos/figures.

NOTE: Turn OFF the power supply before disassembly.

OPERATING PROCEDURE	PHOTOS/FIGURES
<p>1. Removing the cabinet</p> <p>(1) Remove the screw fixing the service panel. (2) Pull down the service panel and remove it. (3) Remove the screws fixing the conduit cover. (4) Remove the conduit cover. (Photo 4) (5) Remove the screw fixing the conduit plate. (Photo 5) (6) Remove the conduit plate. (7) Disconnect the power supply wire and indoor/outdoor connecting wire. (8) Remove the screws fixing the top panel. (9) Remove the top panel. (10) Remove the screws fixing the cabinet. (11) Remove the cabinet. (12) Remove the screws fixing the back panel. (13) Remove the back panel.</p> <p>Photo 2</p> <p>Screws of the top panel Screws of the cabinet</p>	<p>Photo 1</p> <p>Screws of the top panel Back panel Screws of the back panel Service panel Screws of the cabinet</p> <p>Photo 3</p> <p>Screw of the cabinet Screws of the terminal block support and the back panel Direction to remove Screws of the cabinet Hooks</p>

OPERATING PROCEDURE

PHOTOS/FIGURES

Photo 4

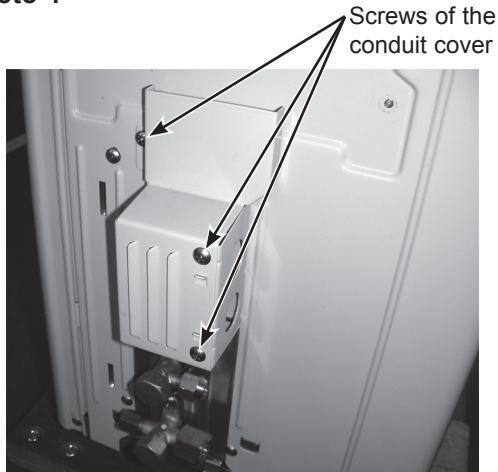
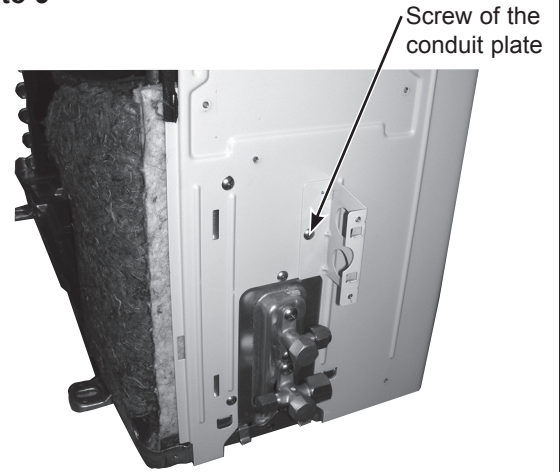

Photo 5



2. Removing the inverter assembly, inverter P.C. board

- (1) Remove the cabinet and panels. (Refer to 1.)
- (2) Disconnect the lead wire to the reactor and the following connectors:
<Inverter P.C. board>
CN721 (R.V. coil)
CN722 (Defrost heater and heater protector) (**SUZ-KA09/12/15NAH2**)
CN931, CN932 (Fan motor)
CN641 (Defrost thermistor and discharge temperature thermistor)
CN643 (Ambient temperature thermistor)
CN644 (Outdoor heat exchanger temperature thermistor)
CN724 (LEV)
- (3) Remove the compressor connector (CN61).
- (4) Remove the screws fixing the heat sink support and the separator.
- (5) Remove the fixing screws of the terminal block support and the back panel.
- (6) Remove the inverter assembly.
- (7) Remove the screw of the ground wire and screw of the terminal block support.
- (8) Remove the heat sink support from the P.C. board support.
- (9) Remove the screw of the inverter P.C. board and remove the inverter P.C. board from the P.C. board support.

Photo 6

Screws of the heat sink support and the separator

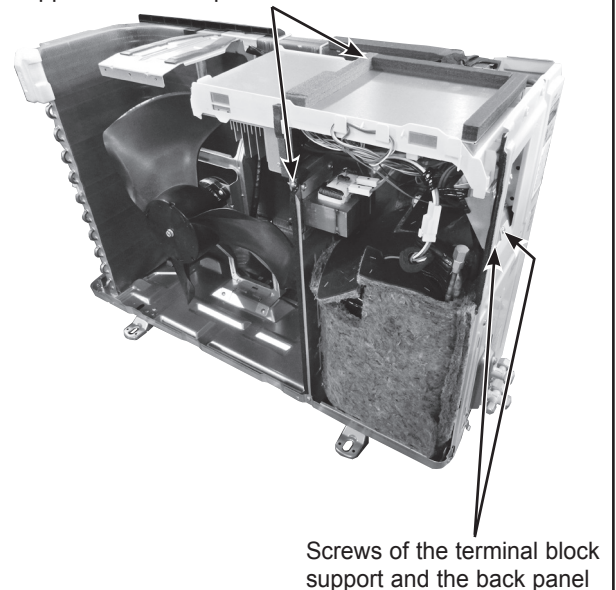

Screws of the terminal block support and the back panel

3. Removing R.V. coil

- (1) Remove the cabinet and panels. (Refer to 1.)
- (2) Disconnect the following connectors:
<Inverter P.C. board>
CN721 (R.V. coil)
- (3) Remove the R.V. coil.

Photo 7

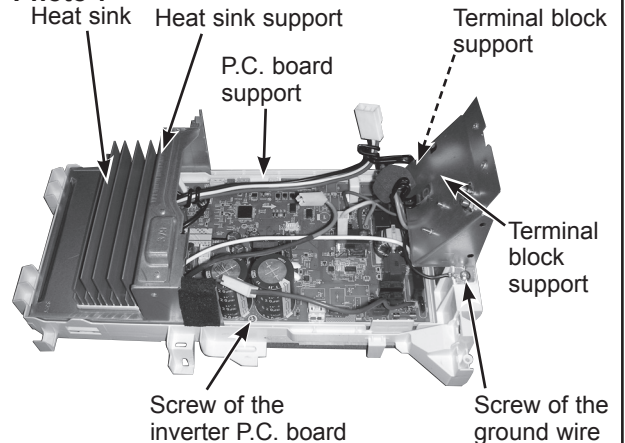

OPERATING PROCEDURE

4. Removing the discharge temperature thermistor, defrost thermistor, outdoor heat exchanger temperature thermistor and ambient temperature thermistor

- (1) Remove the cabinet and panels. (Refer to 1.)
- (2) Disconnect the lead wire to the reactor and the following connectors:
<Inverter P.C. board>
CN641 (Defrost thermistor and discharge temperature thermistor)
CN643 (Ambient temperature thermistor)
CN644 (Outdoor heat exchanger temperature thermistor)
- (3) Pull out the discharge temperature thermistor from its holder.
- (4) Pull out the defrost thermistor from its holder.
- (5) Pull out the outdoor heat exchanger temperature thermistor from its holder.
- (6) Pull out the ambient temperature thermistor from its holder.

PHOTOS/FIGURES

Photo 8

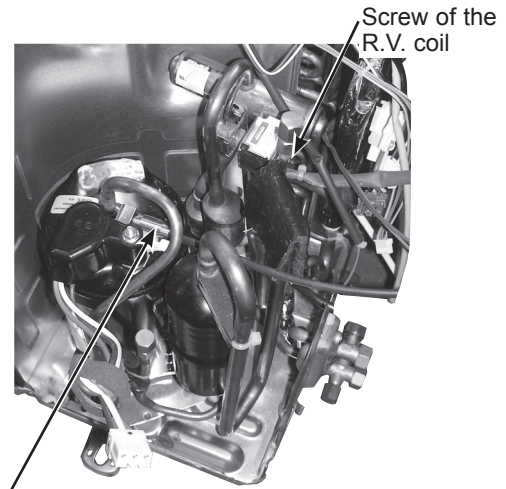

Discharge temperature thermistor

Photo 9

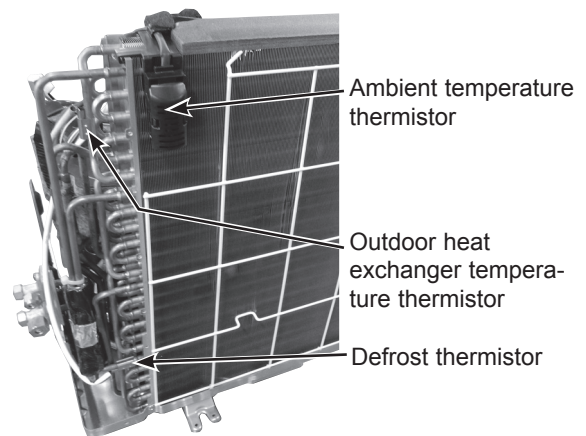

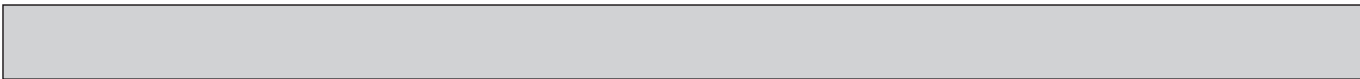

mitsubishi electric corporation

HEAD OFFICE: TOKYO BUILDING., 2-7-3, MARUNOUCHI, CHIYODA-KU, TOKYO100-8310, JAPAN
