

# Installation Instructions

## Model Number FDV451 & MQFDV453

### Free Standing Direct Vent Gas Stove



Stock #s: FDV451N, FDV451NE, FDV451LP, FDV451LPE,  
MQFDV453N, MQFDV453NE, MQFDV453LP, MQFDV453LPE are

Certified to: ANSI Z21.88-2014 • CSA 2.33-2014

**⚠ WARNING:**  
**FIRE OR EXPLOSION HAZARD**  
Failure to follow safety warnings exactly could result in serious injury, death, or property damage.

- Do not store or use gasoline or other flammable vapors and liquids in the vicinity of this or any other appliance.
- **WHAT TO DO IF YOU SMELL GAS**
  - Do not try to light any appliance.
  - Do not touch any electrical switch; do not use any phone in your building.
  - Leave the building immediately.
  - Immediately call your gas supplier from a neighbor's phone. Follow the gas supplier's instructions.
  - If you cannot reach your gas supplier, call the fire department.
- Installation and service must be performed by a qualified installer, service agency or the gas supplier.

This appliance may be installed in an aftermarket permanently located, manufactured home (USA only) or mobile home, where not prohibited by local codes.

This appliance is only for use with the type of gas indicated on the rating plate. This appliance is not convertible for use with other gases, unless a certified kit is used.

**INSTALLER:** Leave this manual with the appliance.  
**CONSUMER:** Retain this manual for future reference.

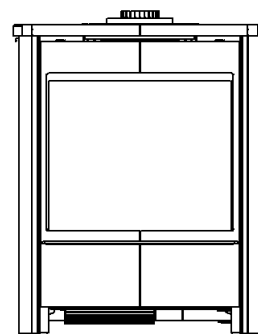

**⚠ DANGER**



**HOT GLASS WILL CAUSE BURNS.**  
**DO NOT TOUCH GLASS UNTIL COOLED.**  
**NEVER ALLOW CHILDREN TO TOUCH GLASS.**

A barrier designed to reduce the risk of burns from the hot viewing glass is provided with this appliance and shall be installed for the protection of children and other at-risk individuals.



A Division of R-Co. Inc.  
2340 Logan Avenue  
Winnipeg, Manitoba, Canada R2R 2V3  
Ph: (204) 632-1962  
Printed in Canada February 20, 2018  
Part # 451-MAN-14

# Table of Contents

## INFORMATION

|  |     |
|--|-----|
| Table of Contents.....   | 2-3 |
| Glass Safety / Termination Cap Safety- All Units.....                | 4   |
| Warnings, Installations, and Operations.....                         | 5-6 |
| Pre-installation Questions and Answers / Operating Instructions..... | 7   |
| Mobile Home/Manufactured Housing Installation.....                   | 8   |

## FDV451 / MQFDV453 INSTALLATION

|   |    |
|---|----|
| Locating Your Appliance / Fireplace Dimensions..... | 9  |
| Clearance to Combustibles.....                      | 9  |
| Gas Line Installation.....                          | 10 |

## GENERAL INSTALLATION, USE, AND MAINTENANCE

|  |       |
|--|-------|
| Fan Installation.....  | 11    |
| Split Receptacle- Switch Control Outside of Fireplace.....               | 12    |
| Door and Glass Information.....  | 13    |
| FDV451 / MQFDV453 Glass Front Door Removal / Installation.....           | 14    |
| MQ453 Glass Side Door Removal / Installation.....                        | 15    |
| Important Information For Door Fronts, Vent Lids, And Side Doors.....    | 16    |
| F450F Front Door Kit -Door Face with Safety Screen and Vent Lid.....     | 17    |
| Vent Lid Installation.....   | 18    |
| F451SD / MQ453SD Side Door Kits.....                                     | 19    |
| FDV453 Side Door Panel Screen Removal.....                               | 20    |
| F451RL / F453RL Brick Liner Installation .....                           | 21    |
| Brick Clip Update for F451RL Side Brick and F451PL Porcelain Liners..... | 22    |
| F451PL / F453PL Porcelain Liner Installation .....                       | 23    |
| 51UHS Box / Component Locations.....                                     | 24    |
| Proflame 2 Box / Component Locations.....                                | 25    |
| F45LG Log Grate Installation.....  | 26    |
| LOGF451 Oak Log Set.....   | 27-28 |
| LOGF452 Oak Log Set.....   | 29-30 |
| MQ453LOG Driftwood Log Set.....  | 31-32 |
| RBCB1 Cannonballs.....   | 33    |
| MQ Dealer Accessories.....   | 34    |
| MQ Stone Decorative Stone Set.....                                       | 35    |
| Millivolt System, Lighting, and Burner Control.....                      | 36    |
| Burner System Maintenance.....   | 37    |
| Restrictor Baffle Setting for Gas Conversions.....                       | 38    |
| Gas Conversion- Part A.....  | 39    |
| Gas Conversion Kit For Top Convertible Pilot- Part B.....                | 40    |
| Gas Conversion for Modulator- Part C.....                                | 41    |
| Burner Removal.....  | 42    |

## PROFLAME 1 IPI SYSTEM

|   |    |
|---|----|
| IPI Electronic Ignition System.....   | 43 |
| Remote Control Operation.....   | 44 |
| IPI Electronic Ignition Parts List – Standard System.....                               | 45 |
| Configuration 1: Basic Manual Hi / Lo and manual Off.....                               | 46 |
| Configuration 2: Remote On / Off and manual Hi / Lo.....                                | 47 |
| Operating the Receiver Without Batteries For GT / EGT / GTM / EGTM Remote Controls..... | 48 |
| Configuration 3: Remote ON/OFF, Variable HI/LO, and Fan.....                            | 49 |
| Electronic Ignition Lighting Instructions.....  | 48 |

**PROFLAME 2 IPI SYSTEM**

Parts List, Basic System..... 51  
Proflame 2 GTMFL..... 51  
Proflame 2 Remote Control..... 52  
Proflame 2 Label..... 53

**VENTING**

Vent Termination..... 54  
General Venting Information..... 55  
Venting Routes And Components..... 56  
Venting Table..... 57  
Horizontal Vent Installation..... 58  
Z47ST24 / Z47ST36 Horizontal Snorkel Terminations..... 59  
Vertical Venting above 12 Feet..... 60  
Vertical Vent Installation..... 61-62  
  
Troubleshooting the Gas Control System..... 63

**PARTS LISTS**

FDV451 / MQFDV453 Parts List..... 64-66

**WARRANTY**

Limited Lifetime Warranty..... 67

## -Glass Safety- All Units

### IT IS THE RESPONSIBILITY OF THE HOME OWNER TO ENSURE THAT NO ONE TOUCHES A HOT APPLIANCE.

If the barrier becomes damaged, the barrier shall be replaced with the manufacturer's barrier for this appliance.

Any safety screen, guard, or barrier removed for servicing the appliance, must be replaced prior to operating the appliance.

- Children and adults should be alerted to the hazards of the high surface temperatures of this appliance and should stay away to avoid burns or ignition of clothing.
- Do not clean when the glass is hot.
- Young children should be carefully supervised when they are in the same room as the appliance. Toddlers, young children and others may be susceptible to accidental contact burns.
- A physical barrier is recommended if there are at risk individuals in the house. To restrict access to a fireplace or stove, install an adjustable safety gate to keep toddlers, young children and other at risk individuals out of the room and away from hot surfaces.
- Do not leave the fireplace remote control where it is accessible to children.

 **DANGER**



**HOT GLASS WILL CAUSE BURNS.**

**DO NOT TOUCH GLASS UNTIL COOLED.**

**NEVER ALLOW CHILDREN TO TOUCH GLASS.**

A barrier designed to reduce the risk of burns from the hot viewing glass is provided with this appliance and shall be installed for the protection of children and other at-risk individuals.

## -Termination Cap Safety- All Units

 **WARNING:**

**A HORIZONTAL VENT CERTIFIED GUARD (SAFETY CAGE) IS AVAILABLE WHEN REQUIRED BY LOCAL CODES.**

### SAFETY CAGES ARE AVAILABLE FOR ALL HORIZONTAL VENT TERMINATIONS. CHECK WITH YOUR DEALER.

- **TERMINATION CAP IS HOT!** Do not place flammable materials on or within 24 inches of termination caps.
- It is imperative that the vent termination be located observing the minimum clearances as shown in manual.
- There must not be any obstruction such as bushes, garden sheds, fences, decks or utility buildings within 24" from the front of the termination plate.
- Do not locate termination where excessive snow or ice build-up may occur. Be sure to check vent termination area after snow falls and clear to prevent accidental blockage of venting system. When using snow blowers, make sure snow is not directed towards vent termination area.
- Venting terminal shall not be recessed into a wall or siding.

# Warnings, Installations and Operations

## Installation Regulations

This gas appliance must be installed by a qualified installer in accordance with local building codes, or in the absence of local codes, with the current CAN/CSA-B149.1 or .2 Installation Code (in Canada) or the current National Fuel Gas Code Z223.1- NFPA 54 when installed in the United States.

This appliance, when installed, must be electrically connected and grounded in accordance with local codes, or in the absence of local codes, with the current CSA C22.1 Canadian Electrical Code or with the National Electrical Code; ANSI/NFPA 70 when installed in the United States.

In the U.S.A. Thermostats are not permitted for Vented Gas Fireplaces (ANSI Z21.50b-Decorative).

# WARNING

## FOR SAFE INSTALLATION AND OPERATION OF YOUR GAS FIREPLACE PLEASE NOTE THE FOLLOWING:

1. Do not clean when the glass is hot.
2. Do not use abrasive cleaners.
3. Using a substitute glass will void all product warranties.
4. For safe operation, glass doors must be closed.
5. When purging the gas line, the glass front must be removed.
6. Do not strike or abuse glass. Take care to avoid breakage.
7. Do not alter gas orifice.
8. No substitute materials may be used other than factory supplied components.
9. This appliance gives off high temperatures and should be located out of heavy traffic areas and away from furniture and draperies.
10. Children and adults should be alerted to the hazards of the high surface temperatures of this appliance and should stay away to avoid burns or ignition of clothing.
11. Young children should be carefully supervised when they are in the same room as the appliance. Toddlers, young children and others may be susceptible to accidental contact burns. A physical barrier is recommended if there are at risk individuals in the house. To restrict access to a fireplace or stove, install an adjustable safety gate to keep toddlers, young children and other at risk individuals out of the room and away from hot surfaces.
12. Under no circumstances should any solid fuels (wood, paper) be used in this appliance.
13. Under no circumstances should this appliance be modified. Any parts that have to be removed for servicing should be replaced prior to operating this appliance.
14. Any safety screen, guard, or barrier removed for servicing an appliance must be replaced prior to operating the appliance.
15. Installation and repair should be done by a qualified service person. The appliance should be inspected before use and at least annually by a professional service person. More frequent cleaning may be required due to excessive lint from carpeting, bedding material, et cetera. It is imperative that control compartments, burners and circulating air passageways of the appliance be kept clean. Make sure that the gas valve and pilot light are turned off before you attempt to clean this unit.
16. Clothing or other flammable material should not be placed on or near the appliance. This appliance should not be used as a drying rack for clothing nor should Christmas stockings or decorations be hung from it.
17. Do not use this heater if any part has been under water. Immediately call a qualified service technician to inspect the heater and to replace any part of the control system and any gas control which has been under water.
18. Do not operate appliance unless completely installed as per installation instructions.
19. Failure to position the parts in accordance with these diagrams or failure to use only parts specifically approved with this appliance may result in property damage or personal injury.
20. **WARNING: Do not operate appliance with the glass front removed, cracked or broken. Replacement of the glass should be done by a licensed or qualified service person.**
21. The appliance area must be kept clear and free from combustible materials, gasoline, and other flammable vapors and liquids.
22. The front of the fireplace gives off high temperatures that could ignite combustible material which is kept close to the front of the unit.
23. Ensure that power to the Fireplace is turned off before servicing.
24. Do not operate this Fireplace without the glass front or with a broken glass.
25. Improper installation, adjustment, alteration, service or maintenance can cause injury or property damage. Refer to the owner's information manual provided with this appliance. For assistance or additional information consult a qualified installer, service agency, or the gas supplier.
26. Operation of this appliance when not connected to a properly installed and maintained venting system or tampering with the blocked vent shutoff system can result in carbon monoxide (CO) poisoning and possible death.
27. This appliance is equipped with a three-prong (grounding) plug for your protection against shock hazard and should be plugged directly into a properly grounded three-prong receptacle. Do not cut or remove the grounding prong from this plug.

### DANGER



**HOT GLASS WILL CAUSE BURNS.  
DO NOT TOUCH GLASS UNTIL COOLED.  
NEVER ALLOW CHILDREN TO TOUCH GLASS.**

A barrier designed to reduce the risk of burns from the hot viewing glass is provided with this appliance and shall be installed for the protection of children and other at-risk individuals.

- Gas fired appliances may be used only for supplemental heat and/or decorative purposes and under no circumstances shall they provide a primary heat source.
- This appliance must not be connected to a chimney flue serving a separate solid-fuel burning appliance.

NOTE: It is recommended that a Carbon Monoxide (CO) Detector be installed in or near bedrooms and on all levels of your home. Place a detector about 15ft [4.5m] outside the room that houses your gas appliance.

**Certified for installation in a bedroom or bed/sitting room. In Canada must be installed with listed millivolt thermostat.**

**In the U.S.A. Thermostats are not permitted for Vented Gas Fireplaces (ANSI Z21.50b-Decorative).**

**In USA see local codes.**

## Operations and Maintenance Instructions

For safe installation and operation note the following:

- Venting systems should be periodically examined by a qualified agency.
- The flow of combustion and ventilation air must not be obstructed.
- The Burner/Log Assembly has been engineered and permanently adjusted for proper flame control.
- Periodically remove the logs from the grate assembly and vacuum any loose particles from the grate and burner areas. See Log Placement page to remove logs. Vacuum burner parts and replace logs.
- Never use your gas fireplace as a cooking device.
- Label all wires prior to disconnection when servicing controls. Wiring errors can cause improper and dangerous operation. Verify proper operation after servicing.

## Installation Requirements for the Commonwealth of Massachusetts

In the Commonwealth of Massachusetts, the installer or service agent shall be a plumber or gas fitter licensed by the Commonwealth. When installed in the Commonwealth of Massachusetts or where applicable codes; the unit shall be installed with a CO detector per the requirements listed below.

1. For direct-vent appliances, mechanical-vent heating appliances or domestic hot water equipment, where the bottom of the vent terminal and the air intake is installed below four feet above grade the following requirements must be satisfied:
  - A. If there is not one already present, on each floor level where there are bedroom(s), a carbon monoxide detector and alarm shall be placed in the living area outside the bedroom(s). The carbon monoxide detector shall comply with NFPA 720.
  - B. A carbon monoxide detector shall be located in the room that houses the appliance or equipment and shall:
    - Be powered by the same electrical circuit as the appliance or equipment such that only one service switch services both the appliance and the carbon monoxide detector;
    - Have battery back-up power;
    - Meet ANSI/UL 2034 Standards and comply with NFPA 720; and
    - Have been approved and listed by a Nationally Recognized Testing Laboratory as recognized under 527 CMR.
  - C. A Product-approved vent terminal must be used, and if applicable, a Product-approved air intake must be used. Installation shall be in strict compliance with the manufacturer's instructions. A copy of the installation instructions shall remain with the appliance or equipment at the completion of the installation.
  - D. A metal or plastic identification plate shall be mounted at the exterior of the building, four feet directly above the location of vent terminal. The plate shall be of sufficient size to be easily read from a distance of eight feet away, and read "Gas Vent Directly Below".
2. For direct-vent appliances, mechanical-vent heating appliances or domestic hot water equipment where the bottom of the vent terminal and the air intake is installed above four feet above grade the following requirements must be satisfied:
  - A. If there is not one already present, on each floor level where there are bedroom(s), a carbon monoxide detector and alarm shall be placed in the living area outside the bedroom(s). The carbon monoxide detector shall comply with NFPA 720.
  - B. A carbon monoxide detector shall:
    - Be located in the room that houses the appliance or equipment;
    - Be either hard-wired or battery powered or both; and
    - Shall comply with NFPA 720.

A Product-approved vent terminal must be used, and if applicable, a Product-approved air intake must be used. Installation shall be in strict compliance with the manufacturer instructions. A copy of the installation instructions shall remain with the appliance or equipment at the completion of the installation.

For the state of Massachusetts a **T-handle gas shut-off valve** must be used on a gas appliance. This T-handle gas shut-off valve must be listed and approved by the state of Massachusetts. This is in reference to the state of Massachusetts state code CMR238.

## Pre-installation Questions and Answers

### About curing of the paint

Your stove or fireplace has been painted with the highest quality silicone stove paint. This paint dries quickly in 15-20 minutes when first applied at the factory. However, due to the high temperature silicone components, the paint will cure when heat is applied to the appliance as it is first used. The following information applies to the curing process to get the paint fully hard and durable.

Fire the appliance four successive times for 10 minutes each firing and a 5 minute cool down between each. Be aware during log and firebox paint curing that a white deposit may be developing on the inside of the glass doors. It is important to remove this white deposit from the glass doors using a fireplace glass cleaner.

- Babies, small children, pregnant women and pets should leave the area during the cure phase.
- Ventilate well, open doors and windows.
- Do not touch during curing.

### Why does my fireplace or stove give off odour?

It is normal for your fireplace to give off some odor at first. This is due to the curing of the paint, adhesives, silicones and any undetected oil from the manufacturing process as well as the finishing materials used with the installations (e.g. marble, tile and the adhesives used to adhere this product to the walls can react with heat and cause odours).

It is recommended that you burn your gas fireplace or stove for a minimum of four hours at a time with the fan off (if a fan is present) after the curing of the paint has been completed. These odours can last upward to 40 hours of burn time; keep burning at a minimum of four hours per use until odours dissipate.

### Noise coming from the fireplace?

Noise is caused by the expansion and contraction of metal as the appliance heats up and cools down. This is normal and is similar to the sounds produced by a furnace or heating duct. This noise does not affect the operation or longevity of your fireplace.

It is also normal for the fan to make some noise when it comes on. This noise can be reduced somewhat by turning down the speed of the fan with the variable speed control. Be aware, however, that this will reduce the volume of heated air circulated into the room by the fan.

### Note to the Installer:

Be sure appliance is working properly and its operation (including remote control operation, if included) is fully explained to and understood by the customer.

## Operating Instructions

1. Be sure to read and understand all the instructions in this manual before operation of appliance.
2. Ensure all wiring is correct and properly enclosed to prevent possible shock.
3. Check for gas leaks.
4. Make sure the glass door is properly installed before operation. Never operate the appliance with the glass door removed.
5. Make sure venting and termination cap are installed and unobstructed.
6. If brick or porcelain liners are used, ensure they are installed.
7. Verify that the pilot can be seen when lighting the appliance. If not, the log or rock placement is incorrect.
8. If the unit is turned off, you must wait a minimum of 60 seconds before re-lighting it.

## Mobile Home/Manufactured Housing Installation

This Direct Vent System Appliance must be installed in accordance with the manufacturer's installation instructions and the Manufactured Home Construction and Safety Standard Title 24 CFR, Part 3280, or the current Standard for Fire Safety Criteria for Manufactured Home Installations, Sites, and Communities ANSI/NFPA 501A, and with CAN/CSA Z240 MH Mobile Home Standard in Canada.

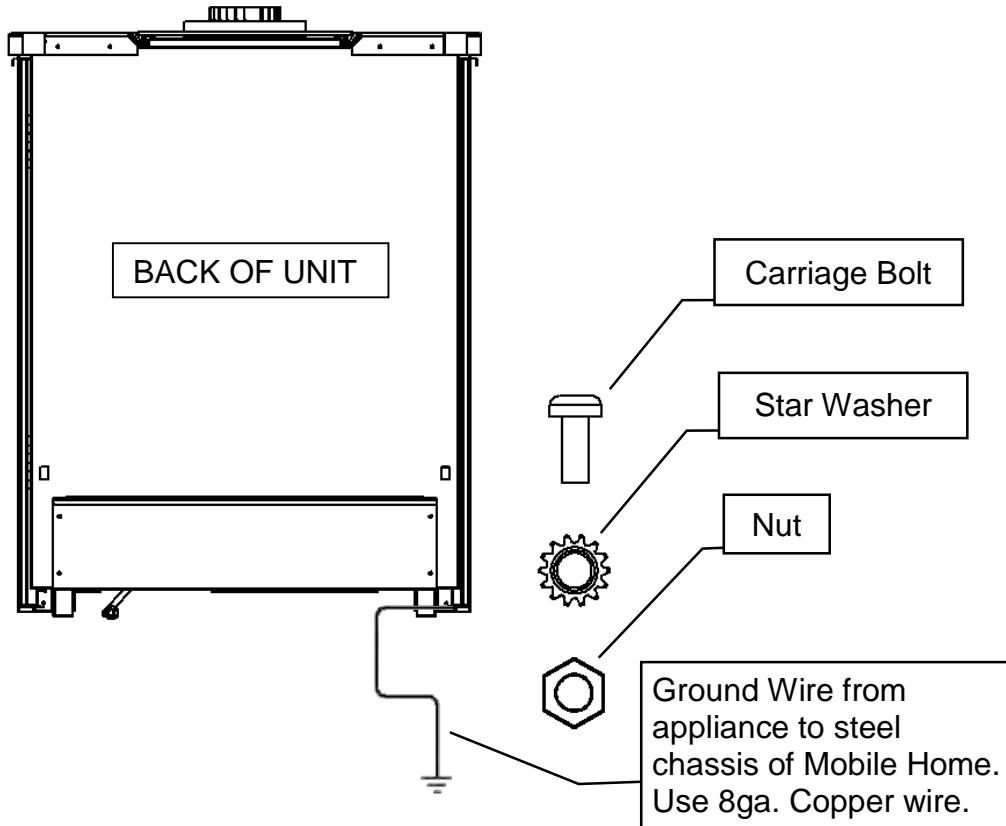

THE VENTED GAS FIREPLACE HEATERS (ANSI Z21.88-2009) IN THIS MANUAL MAY BE INSTALLED IN MANUFACTURED (MOBILE) HOMES AFTER FIRST SALE IN THE USA.

THE VENTED GAS FIREPLACE HEATERS (ANSI Z21.88-2009) IN THIS MANUAL MAY BE INSTALLED IN MANUFACTURED (MOBILE) HOMES IN CANADA.

Please follow the current ANSI/NFPA 70 National Electrical Code in the USA and CAN/CSA C22.1 Canadian National Electrical Code in Canada.

An appliance must be grounded to the steel chassis of the home with 8 ga. copper wire using a serrated or star washer to penetrate paint or protective coating to insure grounding.

Use carriage bolt at the attachment point (see diagram above) to secure the appliance to the floor.

**⚠ Warning:** Do not compromise the structural integrity of the manufactured home wall, floor or ceiling, during installation of appliance or venting.

**For required venting components see venting installation in appropriate section of this manual.**

Certified for installation in a bedroom or bed/sitting room. In Canada must be installed with listed millivolt thermostat. In USA see local codes.



# FDV451 / MQFDV453 Dimensions

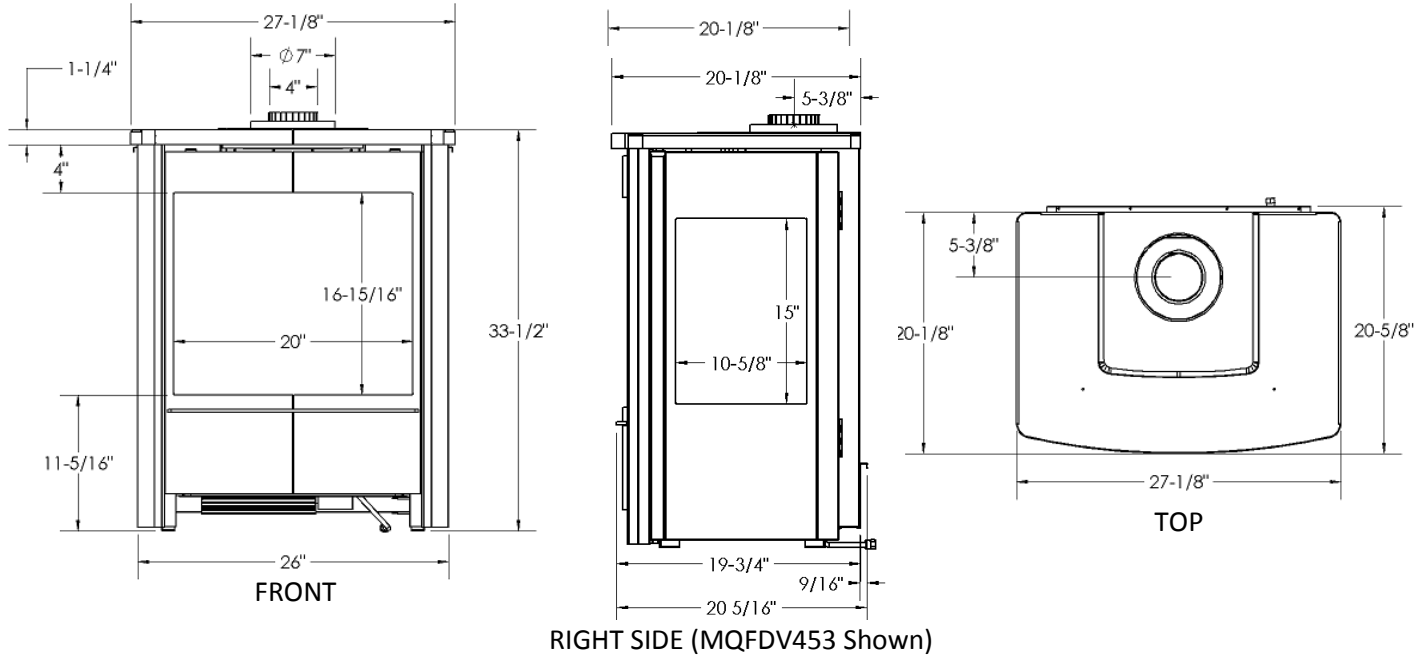

## FDV451 / MQFDV453 Locating Your Appliance / Clearance To Combustibles

The unit should be placed on a hard, stable surface. The appliance may be installed directly on carpeting, tile or other combustible material with no additional floor protection being required.

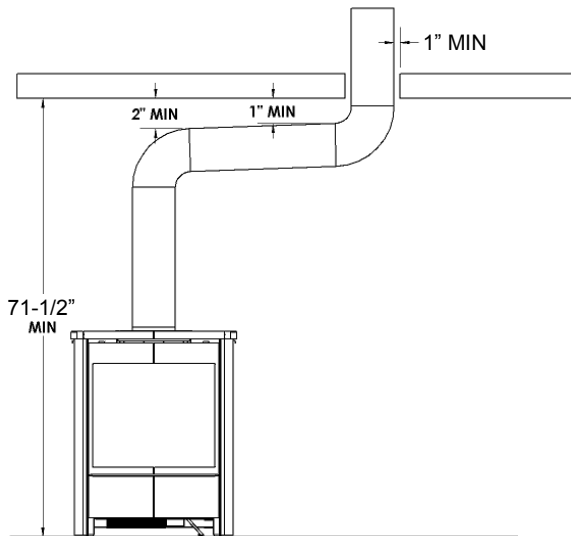
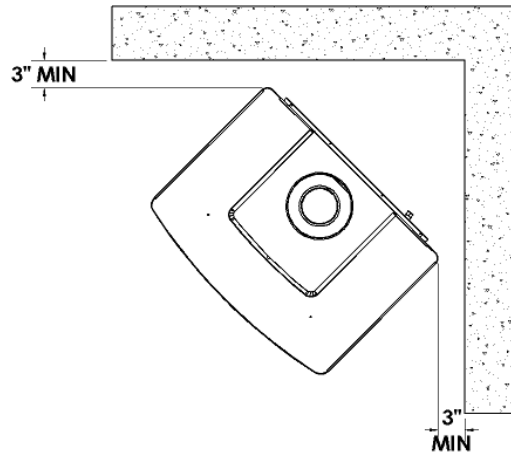
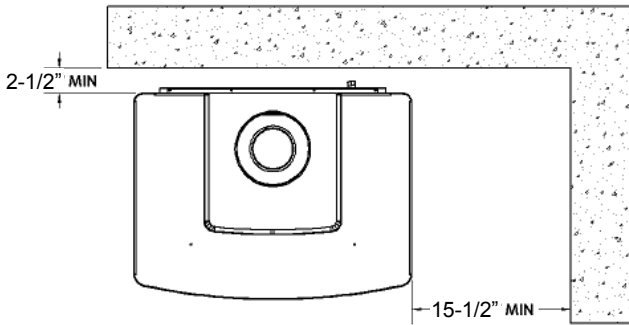

**THE FOLLOWING MINIMUM DISTANCES TO COMBUSTIBLES MUST BE OBSERVED TO ENSURE SAFE OPERATION OF YOUR STOVE.**

| Minimum Distance to Combustibles |         |
|----------------------------------|---------|
| Front                            | 36"     |
| Sides                            | 15-1/2" |
| Back                             | 2-1/2"  |
| Ceiling (from floor)             | 71-1/2" |
| Top of 90° Elbow                 | 2"      |
| Top of Horizontal Pipes          | 1"      |
| Vertical Venting                 | 1"      |

This unit has been tested in an Alcove. The minimum size of the Alcove must be: 48" Deep, 71-1/2" Tall, and 58" Wide.

# Gas Line Installation

This gas appliance should be installed by a qualified installer in accordance with local building codes and with current CAN/CGA - B149.1 or .2 installation codes for Gas Burning appliances and equipment in Canada and the National Fuel Gas Code ANSI Z223 in the U.S.A.

1. The gas pipeline can be brought in through the back or bottom of the unit.
2. The gas control inlet is 3/8" NPT. Typical installation layout for rigid pipe is shown at right.
3. When using copper or flex connector, use only approved fittings. Always provide a union so that gas line can be easily disconnected for burner or fan servicing. See gas specification for pressure details and ratings.
4. When a vertical section of gas pipe is required for the installation, a condensation trap is needed. See CAN/CGA-B149.1 or .2 for code details.
5. For natural gas, a minimum of 3/8" iron pipe with gas minimum pressure of 4.5" w.c. must be used for supply from the gas meter. Consult with the local gas utility if any questions arise concerning pipe sizes.
6. A 1/8" NPT plugged tapping is accessible for test gauge connection both on the inlet and outlet of the gas valve.
7. Turn the gas supply ON and check for leaks. **DO NOT USE OPEN FLAME FOR THIS PURPOSE.** Use an approved leak testing solution.
8. The appliance and its individual shutoff valve must be disconnected from the gas supply piping system during any pressure testing of that system at test pressures in excess of 1/2 PSIG (3.5 KPa).
9. The appliance must be isolated from the gas supply piping system by closing its individual shutoff valve during any pressure testing of the gas supply piping system at test pressures equal to or less than 1/2 PSIG (3.5 KPa).

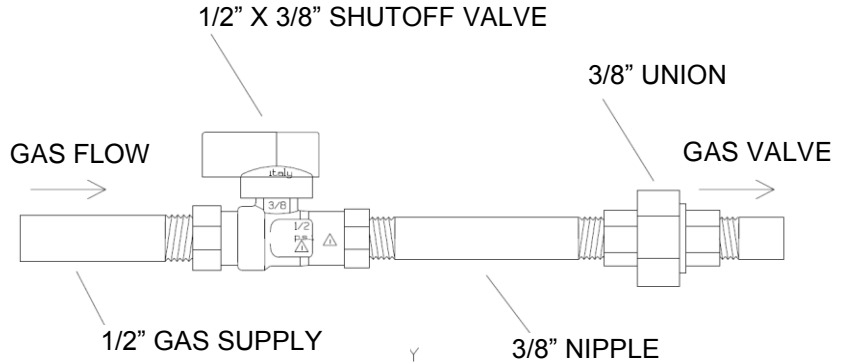

**NOTE:** The gas line connection may be made of 1/2" rigid pipe or an **Approved Kingsman Flex Connector, such as FP15GC.** Since some municipalities have additional local codes, it is always best to consult your local authorities and the current CAN/CGA - B149.1 or .2 installation code in Canada or the National Fuel Gas code ANSI Z223.1 in the U.S.A

For the state of Massachusetts a T-handle gas shut-off valve must be used on a gas appliance. This T-handle gas shut-off valve must be listed and approved by the state of Massachusetts. This is in reference to the state of Massachusetts state code CMR238.

Important: Always check for gas leaks with a soap and water solution. Do not use open flame for leak testing.

## Gas Specifications

| MODELS                                   | FDV451N/NE            | FDV451LP/LPE    | MQFDV453N/NE    | MQFDV453LP/LPE         |
|--|-----------------------|-----------------|-----------------|------------------------|
| Fuel                                     | Natural               | Propane         | Natural         | Propane                |
| Gas Control                              | Millivolt / IPI       | Millivolt / IPI | Millivolt / IPI | Millivolt / IPI        |
| Maximum                                  | 34,500                | 31,000          | 34,500          | 31,000                 |
| Low                                      | 23,750                | 24,500          | 23,750          | 24,500                 |
| Orifice Size<br>(0-4500ft)               | #32                   | #50             | #32             | #50                    |
| Air Shutter                              | 1/4"                  | Fully Open      | 1/4"            | Fully Open             |
| Gas Inlet Size S.I.T. 820 Nova, 3/8" NPT |                       |                 |                 |                        |
| Gas Supply Pressure                      | Minimum               |                 | Normal          | Maximum                |
| Natural Gas                              | 5.5"                  |                 | 7"              | 9"                     |
| Propane                                  | 11"                   |                 | 11"             | 12"                    |
| Manifold Pressure                        | Natural Gas           |                 |                 | Propane                |
| Manifold Pressure High                   | 3.5 IN. W.C./ .87 KPa |                 |                 | 10 IN. W.C./ 2.61 KPa  |
| Manifold Pressure Low                    | 1.6 IN. W.C./ .40 KPa |                 |                 | 6.3 IN. W.C./ 1.57 KPa |

# Fan Installation F450FK FDV451 / MQFDV453

## ⚠ WARNING

### Electrical Grounding Instructions

This appliance is equipped with a three prong (grounding) plug for your protection against shock hazard and should be plugged directly into a properly grounded three-prong receptacle. Do not cut or remove the grounding prong from this.

### Before Servicing

1. Ensure all power supply is shut off.
2. Label all wires prior to disconnecting when servicing control. Wiring errors can cause improper and dangerous operation.
3. For fan servicing: Vacuum and clean lint/dirt build-up on the fan blades and motor.

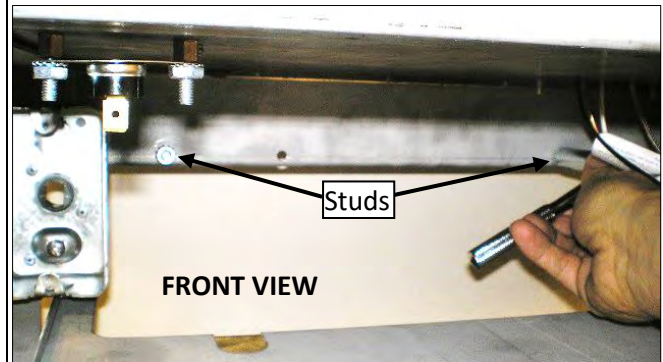
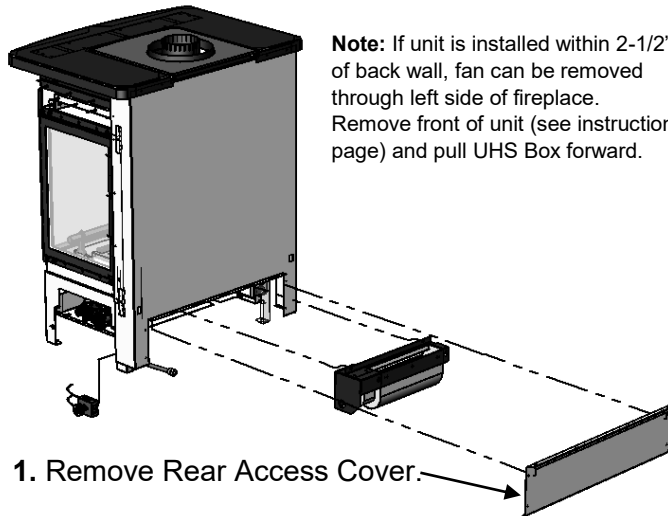
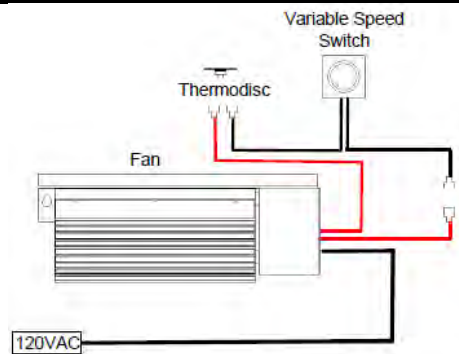

**4. Install variable speed switch into the appropriate hole in right rear leg of appliance.**

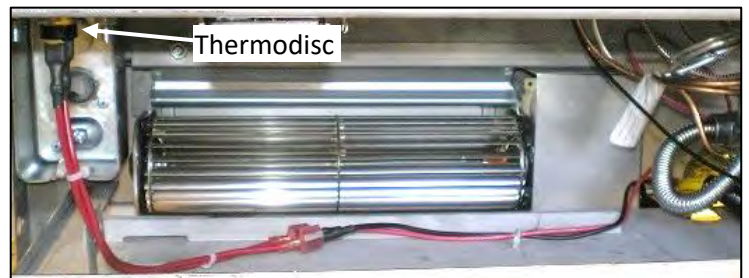
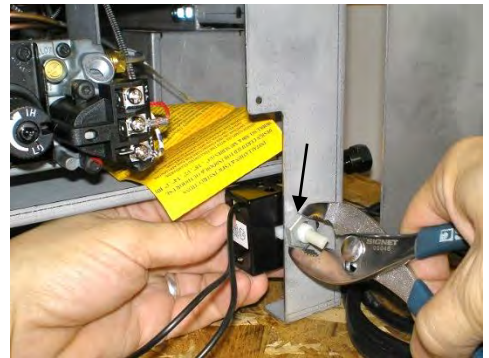

Replace Rear Access Cover (shown in item 1.) once fan is installed.

## Fan Speed Control Outside of Fireplace

If you plan to locate the variable speed control switch for the fan outside of the fireplace and you require a constant source of AC power inside the unit for another accessory such as lights or an IPI valve system, follow one of the procedures below.

### ⚠ WARNING

A qualified electrician must connect electrical wiring to junction outlet for built-in installation.

**Follow all codes.**

### ⚠ WARNING

**Electrical Grounding Instructions –**  
This appliance is equipped with a three – pronged (grounding) plug for your protection against shock hazard and should be plugged directly into a properly grounded three-prong receptacle.

### ⚠ WARNING

Label all wires prior to disconnection when servicing controls. Wiring errors can cause improper and dangerous operation. Verify proper operation and servicing.

**⚠ Caution:** Electrical installation to be done by a qualified installer. All wires must be connected and grounded in accordance with CSA Standard C22.1- Canadian Electrical Code part 1 or with the National Electrical Code, ANSI /NFPA 70 (latest edition) and /or in accordance with local codes.

Switch Controlled Split Receptacle With Switch At START Of Cable Run

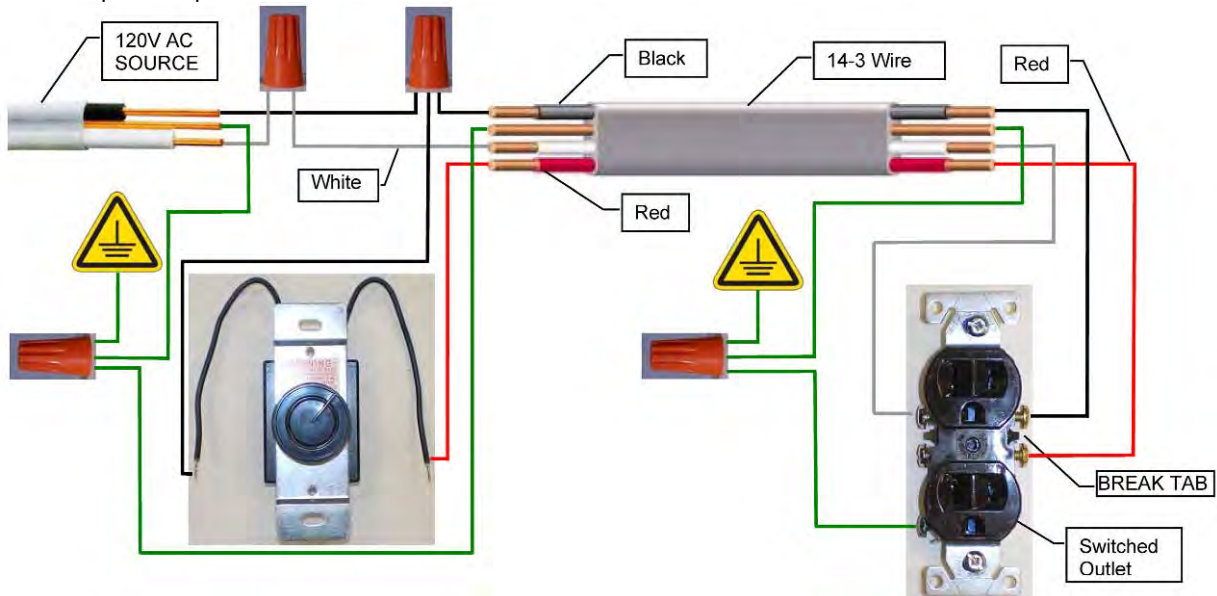

Switch Controlled Split Receptacle With Switch At END Of Cable Run

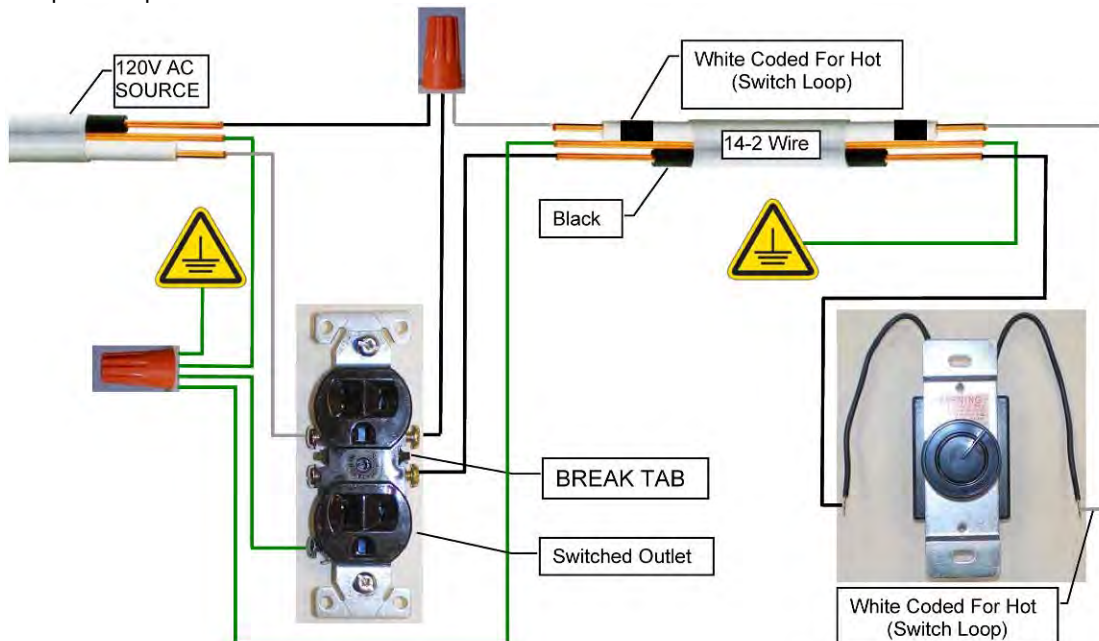

## Door and Glass Information FDV451 / MQFDV453

### Glass Cleaning

It will be necessary to clean the glass periodically. During startup, condensation, which is normal, forms on the inside of the glass, and causes dust, lint etc. to cling to the glass surface.

Also, initial paint curing can deposit a slight film on the glass. It is therefore recommended that initially the glass be cleaned two or three times with a fireplace glass cleaner. After that, the glass should be cleaned two or three times a season depending on the circumstances.



#### Cautions and Warnings

- Do not clean when the glass is hot.
- The use of substitute glass will void all product warranties (see **Glass Replacement** in this section).
- Care must be taken to avoid breakage of the glass.
- Do not operate this fireplace without the glass front or with a broken glass front.
- Do not strike or abuse the glass.

### Glass Replacement

Only Robax ceramic or coated Neoceram glass may be used for replacement for all FDV451 / MQFDV453 Models. Glass must be minimum 5mm thick.

To replace glass, clean all materials from the door frame. Scrape off old silicone all the way down to the metal. Using high-temp silicone [rated up to 500°F (260°C)] apply a continuous bead of approximately 1/8"-3/16" to all four [4] sides of the frame. With the frame resting on a flat surface, insert the new glass with a new gasket. Gently press the glass into the silicone. Be careful not to use excessive force on the glass. Let the silicone dry for approximately 15-20minutes.

**Use caution when removing broken glass. Wear gloves.**

#### Removal of the Glass Front Door

1. Remove the door by unlatching the 2 top latches. Simply place 2 fingers in the grooves, and pull and lift upward slightly.
2. Once the top of the door is unlatched, pull it outward and lower it to unlatch the bottom.
3. To re-install, place the Bottom Door Ledge into the 2 Lower Latch assemblies first. Then swing the door closed to seal it against the firebox cavity. Re-latch the Upper Latch assembly to secure the door to the appliance.

#### Removal of the Glass Side Doors

1. Remove nuts with a 7/16" wrench.
2. Remove Door.

### Spring Replacement

\*Over time, the door latch spring (Part#36HB-123) may need to be replaced if tension is lost.

1. To replace latch spring, remove the 2 hex screws (located in the firebox) that secure the latch assembly in place.
2. Once the screws are removed the latches will slide out of place.
3. Remove the locknut from the latch assembly and replace the spring. Re-tighten the locknut until 2 thread turns are beyond the locknut. This is critical for proper tension. Replace latch assembly.

## FDV451 / MQFDV453 Glass Front Door Removal / Installation

**To Remove Door:** Using supplied latch tool, pull top latches forward and up to release from door.

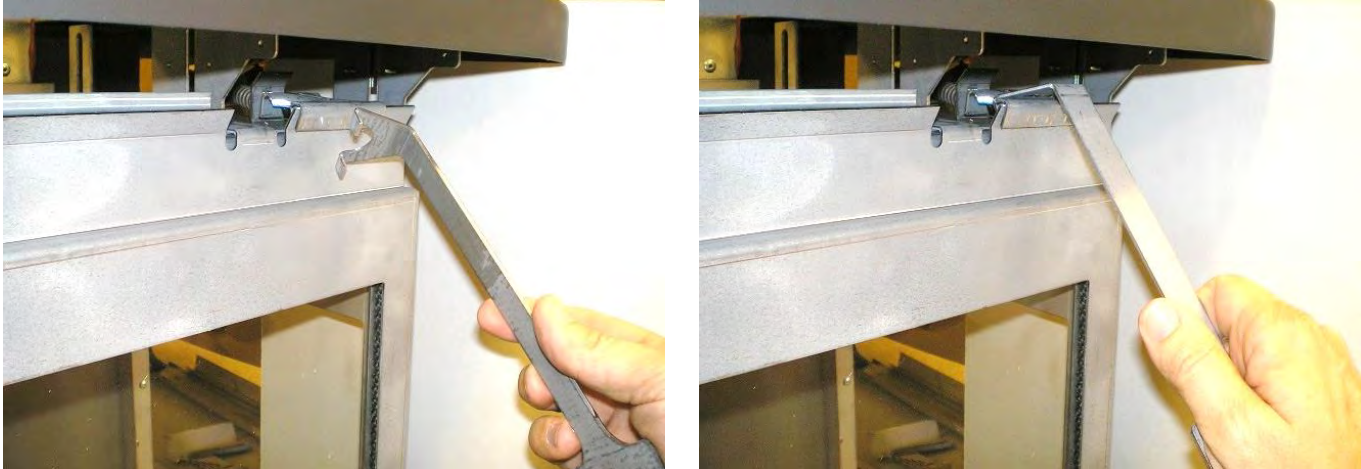

Swing door down and pull away from appliance to release.

**To Install Door:** Engage door in lower latches at an angle of between 5 and 10 degrees below horizontal.

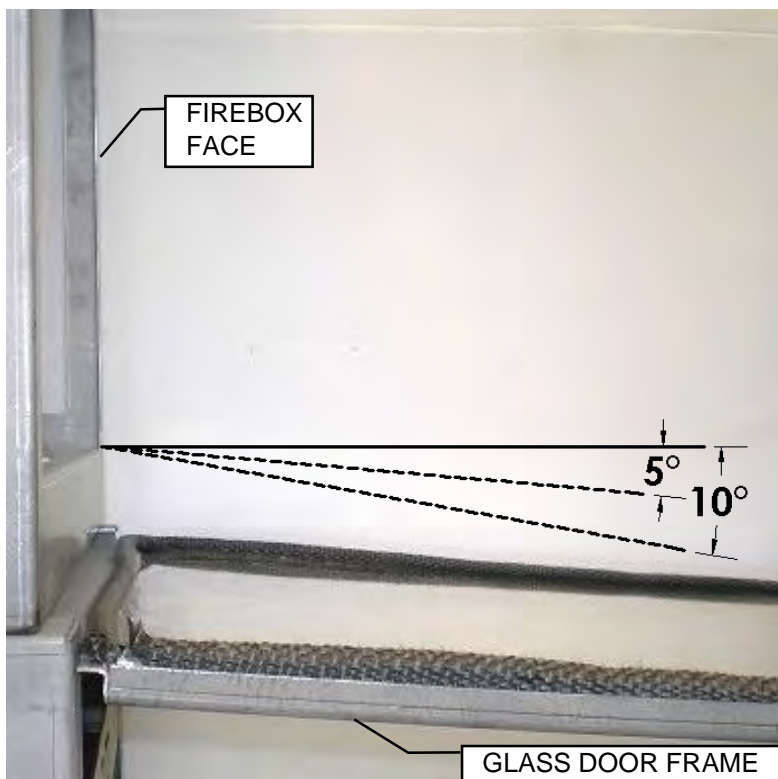

Swing door up and use supplied tool to pull latches over door frame.

### **⚠WARNING:**

Wait until unit is **COMPLETELY** cool before touching glass or attempting to install or remove Glass Door.

**⚠WARNING:** Wait until unit is COMPLETELY cool before touching glass or attempting to install or remove Glass Door.

**To Remove Door:** Remove [4] KEPS nuts with a 7/16" wrench.



**NOTE:** Do not overtighten nuts, as gasket or glass may be damaged

**To Replace Door:** Place Glass Side Door over studs. Tighten KEPS nuts with a 7/16" socket or wrench.

Top of Glass Door Frame



Bottom of Glass Door Frame



**⚠ IMPORTANT INFORMATION FOR DOOR FRONTS, VENT LIDS, AND SIDE DOORS**

**WARNING: SIDE DOOR PANEL GETS EXTREMELY HOT!  
DO NOT OPEN SIDE DOOR PANEL UNTIL UNIT IS COMPLETELY COOL.**



**INSTALLATION NOTES:**

- Cotton gloves must be worn to protect the finish during installation and handling.
- All fingerprints must be cleaned off with a soft cloth prior to burning the unit or they will be permanent.
- Be sure to remove plastic protective film from stainless steel and clean residue with a damp cloth.

**CLEANING NOTES:**

**- FIREPLACE MUST BE COMPLETELY COOL -**

- **STAINLESS STEEL** components may be cleaned with a commercial stainless steel cleaner. Stainless steel may discolor during normal operation. This is normal and should not be considered a defect.
- **POWDER BLACK** components may be cleaned with a ceramic glass cleaner and a microfiber cloth to return the luster.



# FDV451 / MQFDV453

# -F450F Door Front Kit-

Kit contains: [1] Door Face with safety screen, [2] DT Screws, [1] Vent Lid.

**⚠WARNING:** Wait until unit is COMPLETELY cool before touching glass or attempting to install or remove Front Face.

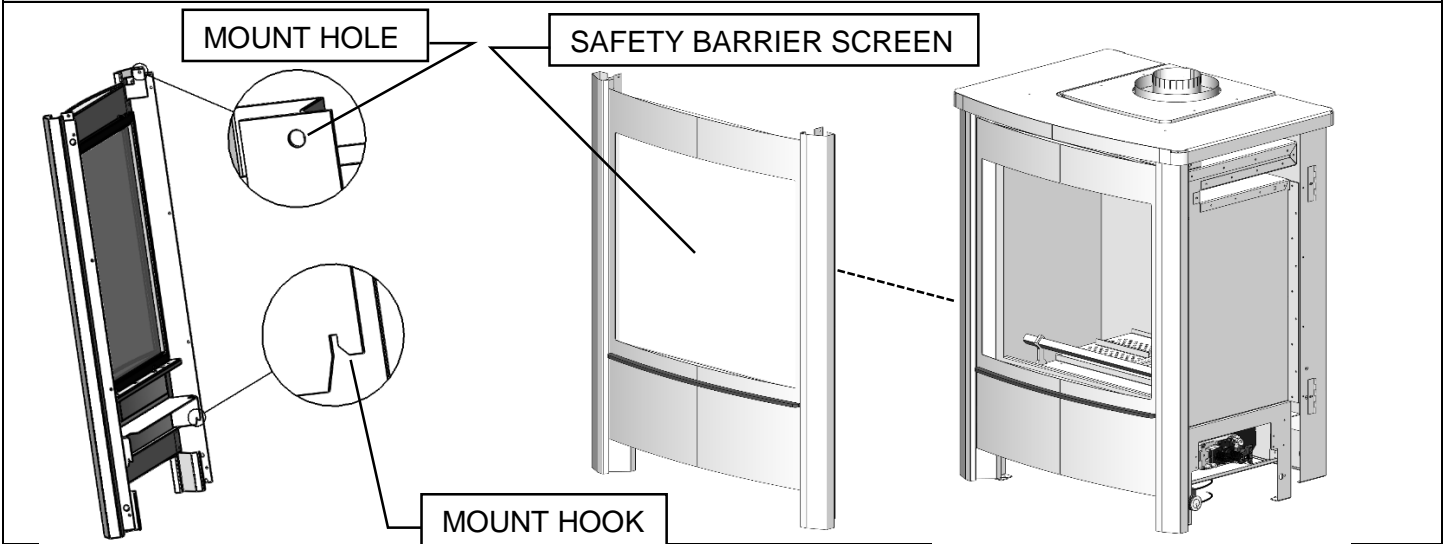

1. Remove the [2] screws from the top mount bracket on each side of the appliance.



2. Insert Door Face under appliance top and engage lower hooks into slots on face of appliance (See next).



3. Once lower hooks are engaged, insert and tighten [1] DT Screw into mounts on upper sides of Door Face. Replace the [2] screws from the top mount bracket on each side of the appliance.

### **IMPORTANT NOTES:**

- Cotton gloves must be worn to protect the finish during installation and handling.
- All fingerprints must be cleaned off with a soft cloth prior to burning the unit or they will be permanent.
- Stainless steel may discolor during normal operation. This is normal and should not be considered a defect.
- Be sure to remove plastic protective film from stainless steel and clean residue with a damp cloth.

## FDV451 / FDV453 Vent Lid Installation

VENT LID MUST BE IN PLACE BEFORE VENTING IS CONNECTED.

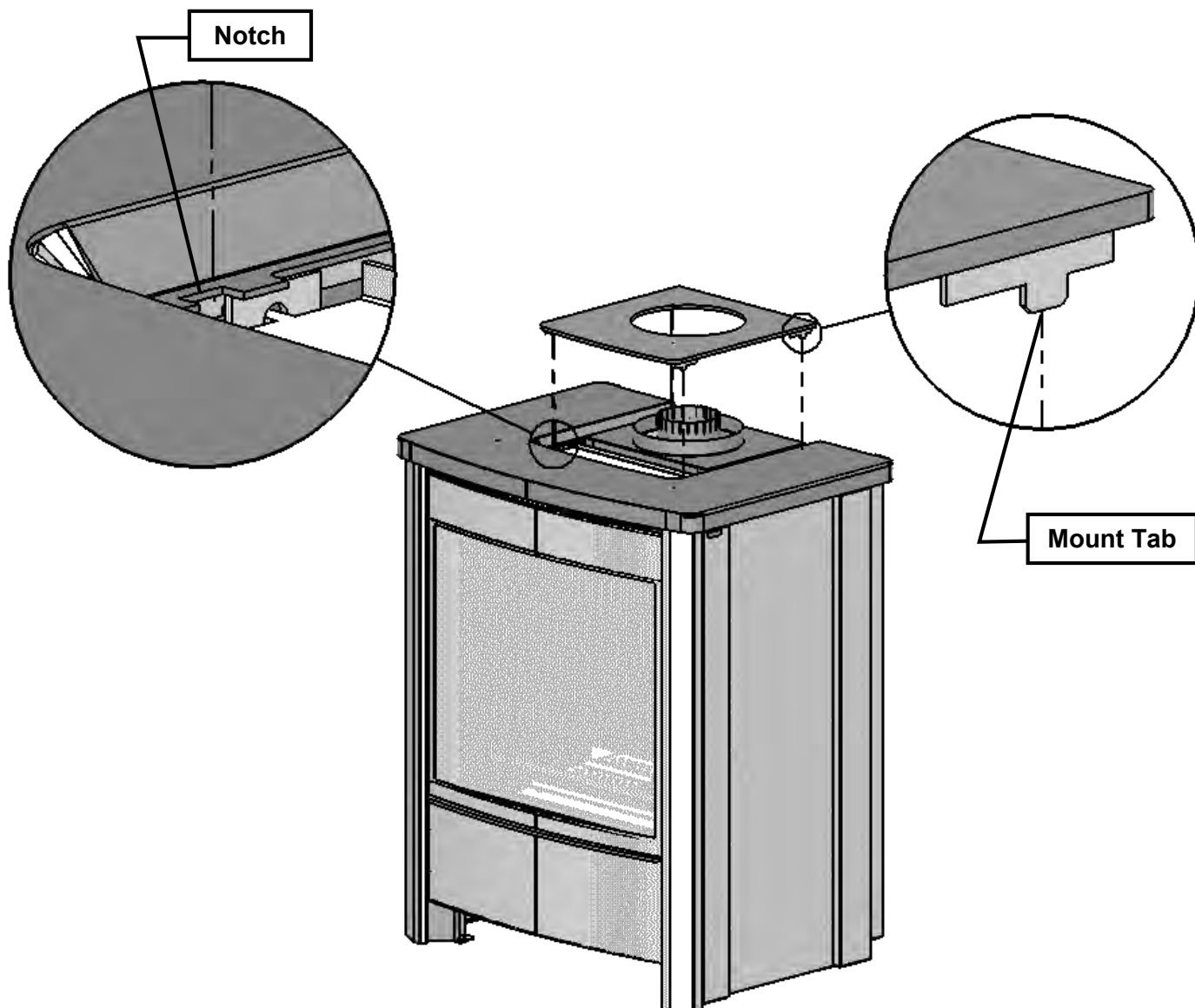

To install Vent Lid:

- Place Vent Lid onto fireplace and center over flue.
- Mount Tabs will engage with notches inside recess on appliance top.
- No fasteners are required.

## F451SD / MQ453SD -Side Door Kits-

Kit contains: [1] Pair of Side Door Panels with safety screens, [4] DT Screws.

**⚠WARNING:** Wait until unit is COMPLETELY cool before touching glass or attempting to install or remove Side Panel.

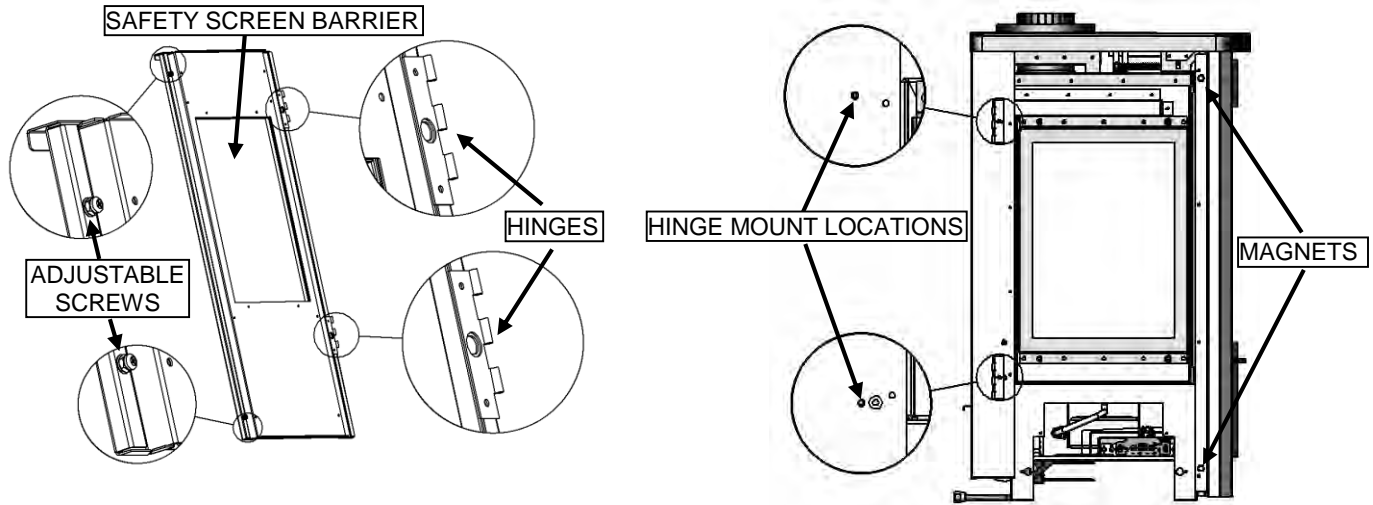

1. Attach Side Door Panels using DT Screws provided.



2. Using DT Screws, adjust position of Side Door Panels (1/16" to 1/8" gap along front edge is optimal).

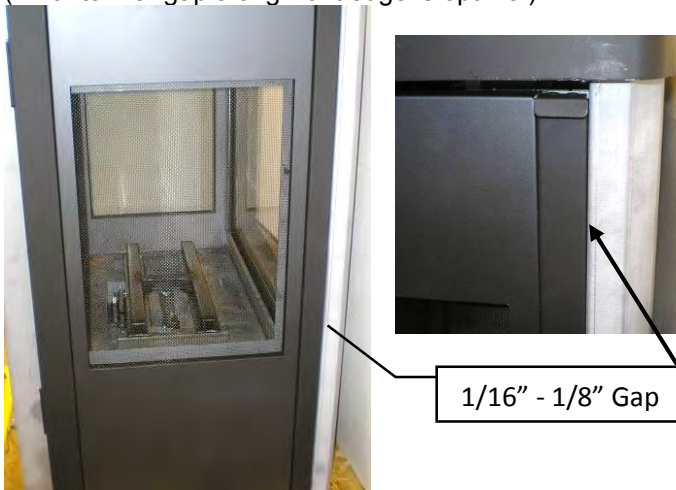

3. Move adjustable screws until face of Side Door Panels are flush with appliance (5/16" wrench and Phillips screwdriver required).



### **IMPORTANT NOTES:**

- Cotton gloves must be worn to protect the finish during installation and handling.
- All fingerprints must be cleaned off with a soft cloth prior to burning the unit or they will be permanent.
- Stainless steel may discolor during normal operation. This is normal and should not be considered a defect.
- Be sure to remove plastic protective film from stainless steel and clean residue with a damp cloth.

## FDV453 Side Door Panel Screen Removal

**Step One:** Using a 1/4" Hex driver, remove the [Qty 8] DT Screws on the inside of the Side Door Panel. Set the Outer Door Panel aside.

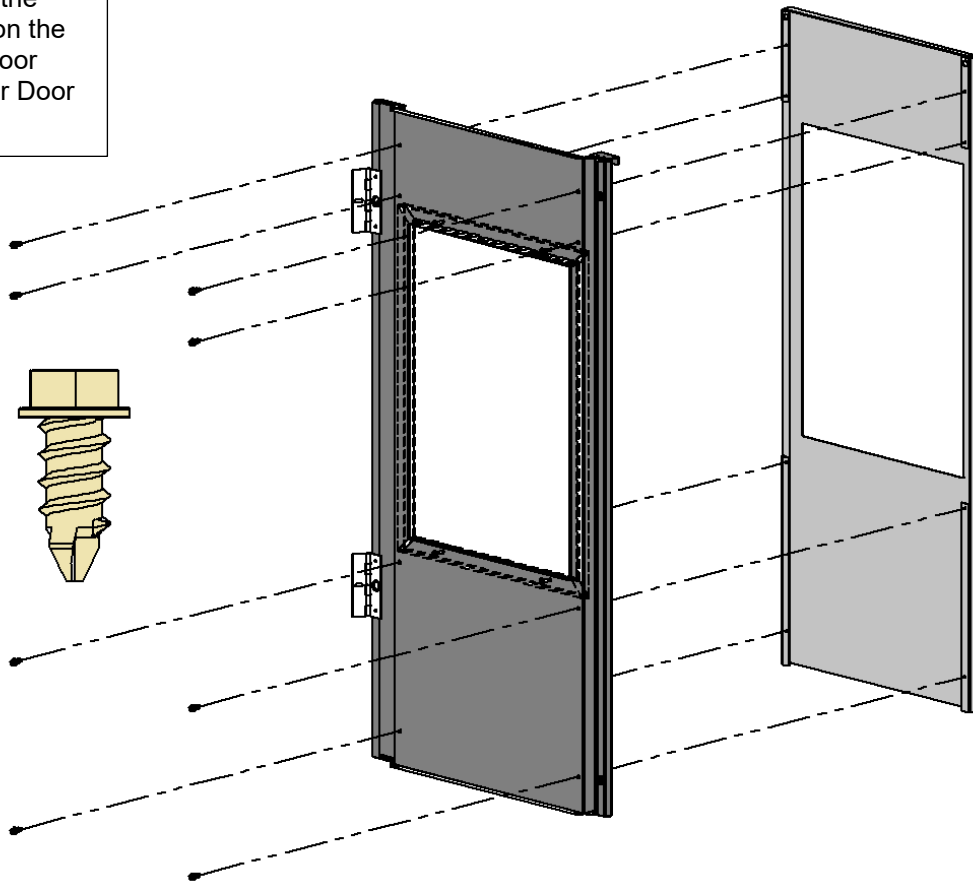

**Step Two:** Using an R1 Robertson or Phillips screw driver, remove the [Qty 4] #6 Black Screws holding the screen in place.

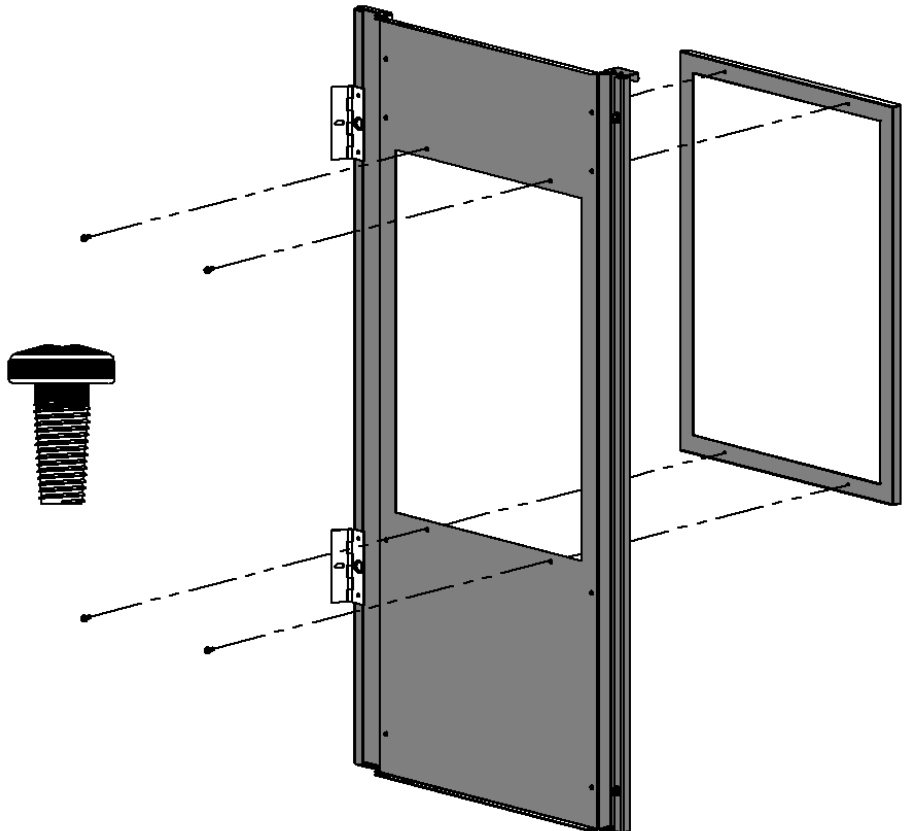

**Step Three:** Replace Screen and Reinstall Outer Door Panel.

## F451RL / F453RL – Brick Liner Installation / Removal

**⚠WARNING:** Failure to position the parts in accordance with these diagrams or failure to use only parts specifically approved with this appliance may result in property damage or personal injury.

**F451RL:** [1] Back Liner, [2] Side Liners  
**F453RL:** [1] Back Liner only

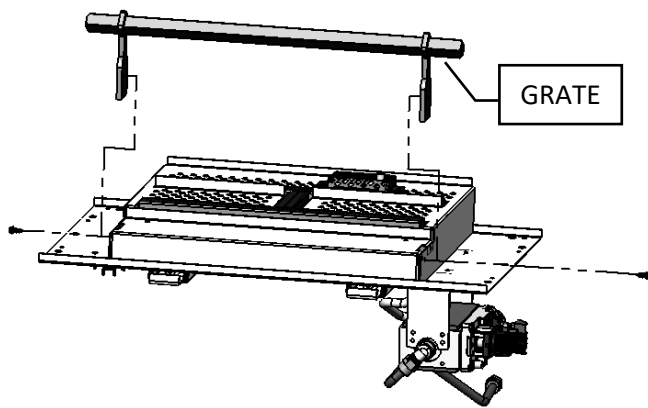

1. Remove [2] DT Screws. Remove Grate from firebox.



2. Tilt back liner back slightly and enter firebox with one top corner first.



3. Carefully move back liner past pilot area.



4. Back Liner is held in place by angle in top of firebox.

**F451RLT / RLH:**



5. Place Side Liners into firebox.



6. Side Liners are held in place by retainer clips- **See Next Page.**

## Brick Clip Update for FDV451 Side Brick Liners

If the Serial Number of the Appliance is above # 1325 For FDV451 Units:

The left and right side Brick Clips are fixed in the Firebox.

Slide Clips upward when installing Left and Right Side Panel.

Pull Brick Clip down to hold Liners in place.

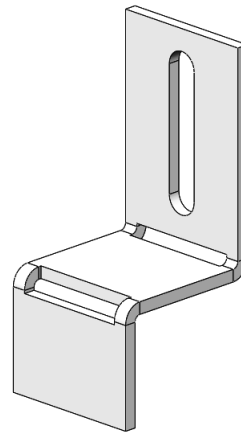

Side Brick Clips in FDV453 slide up and down, but are not removable.

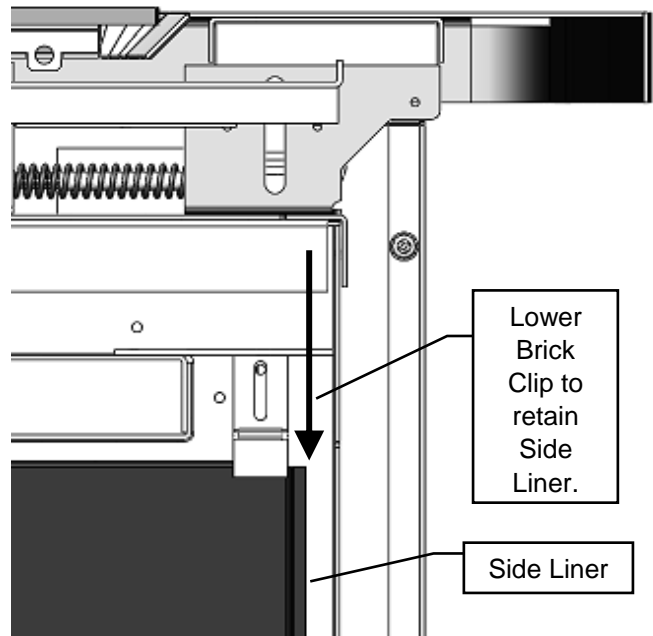
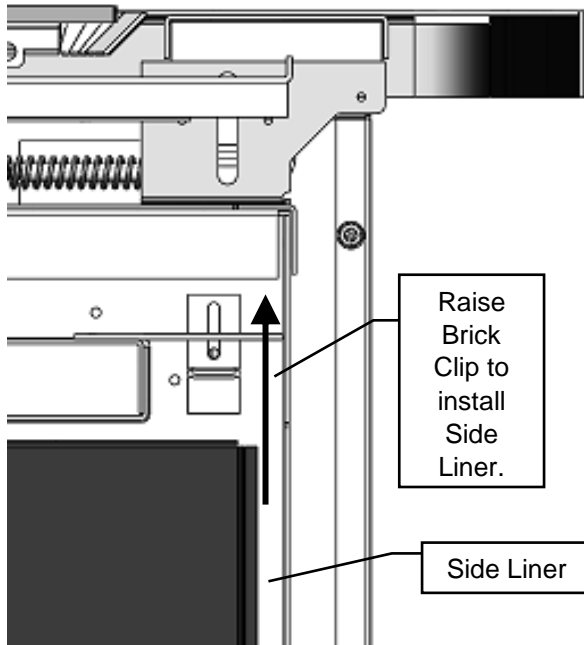

## F451PL / MQ453PL – Porcelain Liner Installation / Removal

**⚠ WARNING:** Failure to position the parts in accordance with these diagrams or failure to use only parts specifically approved with this appliance may result in property damage or personal injury.

**F451PL:** [1] Back Liner, [2] Side Liners  
**MQ453PL:** [1] Back Liner only

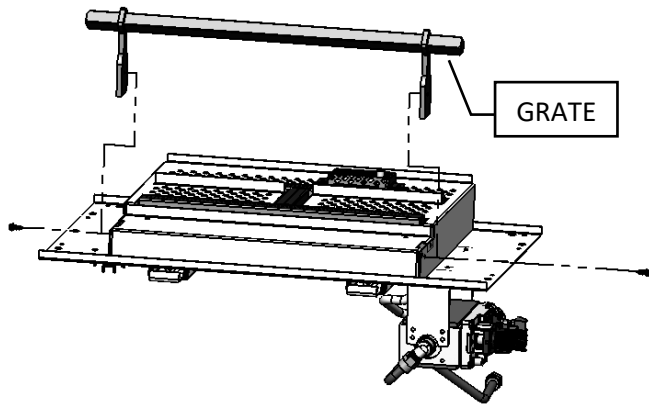

1. Remove [2] DT Screws. Remove Grate from firebox.



2. Tilt back liner back slightly and enter firebox with top left corner first.



3. Carefully move back liner past pilot area.



4. Back Liner is held in place by angle in top of firebox.

**F451PL Side Liners:**



5. Place Side liners into firebox.

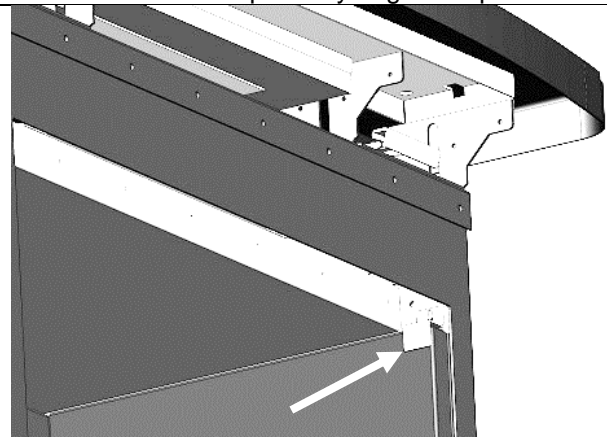

6. Side Liners are held in place by retainer clips in upper front corners of firebox. **See Previous Page.**

**⚠ Note: Warping and Discoloration of Porcelain or Painted Metal Liners Is Not Covered Under Warranty.** Both Porcelain and Painted Metal Liners may discolor and warp during normal operation of your appliance. This is normal, and not considered a defect.

# FDV451 / MQFDV453

# 51UHS Box

INCLUDED WITH BASE MODEL (MILLIVOLT) UNITS.

The 51-UHS Box is designed for millivolt and IPI units for in-unit installation of the Remote Receiver, Fan Control Module, and the IPI Module. 51-UHS Box can be inserted & removed from beneath fireplace through Side panel opening.

**NOTE:** When using a remote control, the 51-UHS Box must be used. Batteries for Remote Receiver can be changed by lifting 51-UHS up through opening.

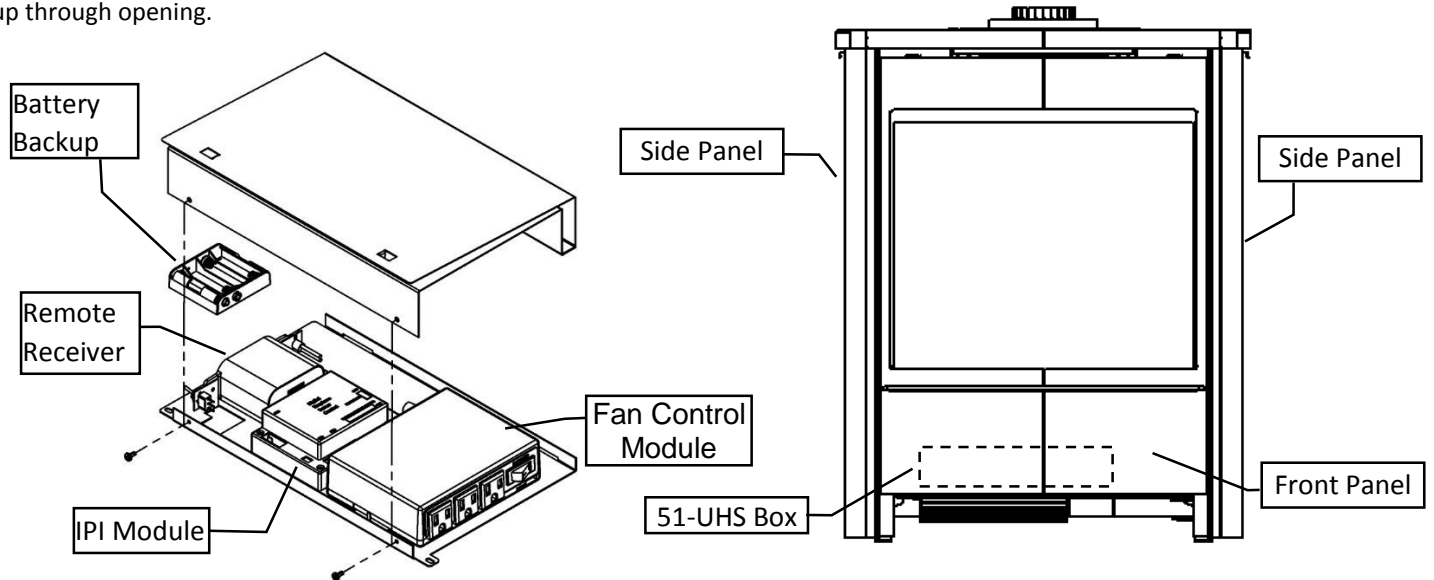

51-UHS can be inserted & removed from beneath fireplace through Side Panel.

## COMPONENT LOCATIONS

(See Each Section For Connections & Wiring)

### TOP VIEW

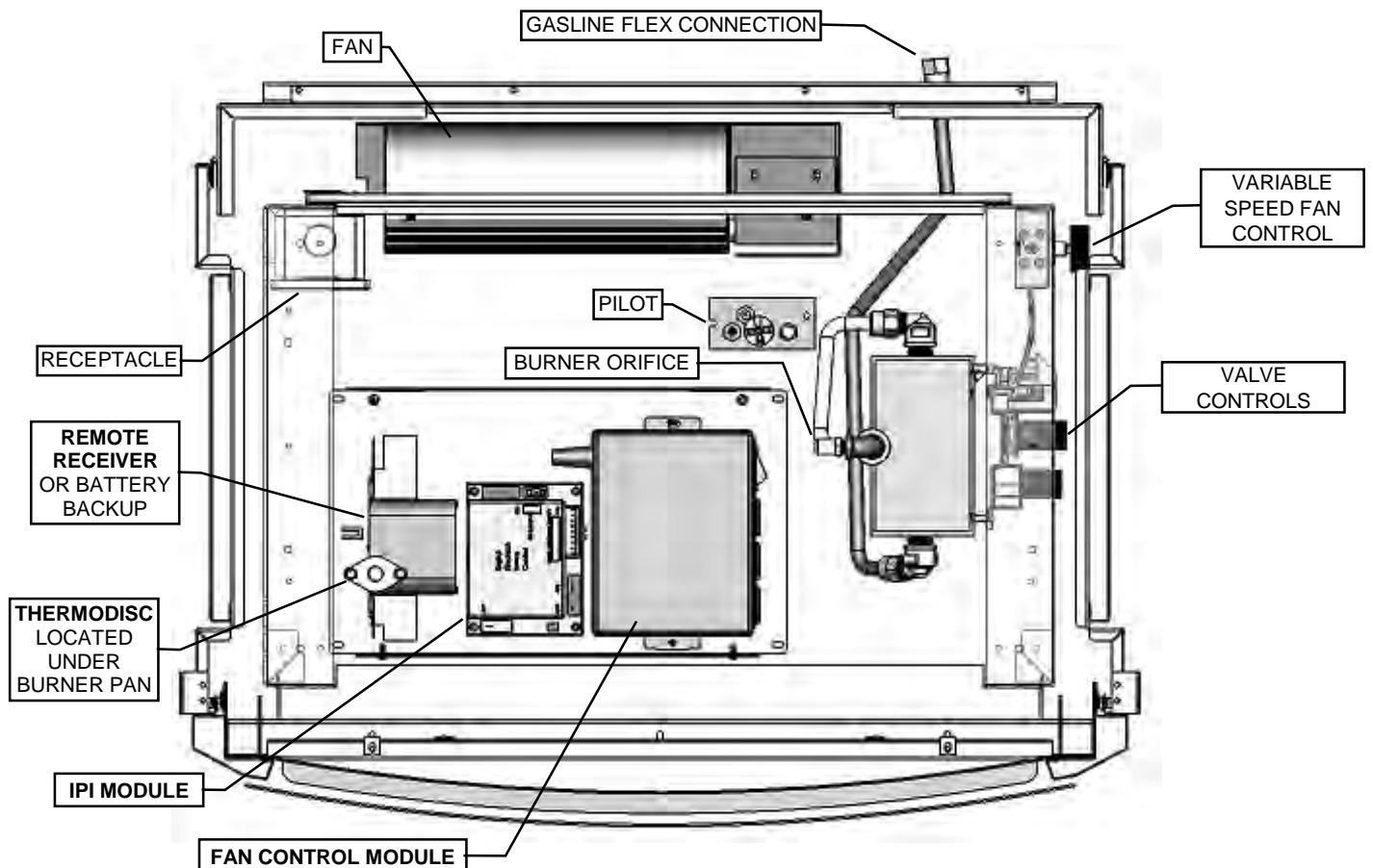



The Proflame2 IFC (Integrated Fireplace Control) board is a device that allows the automatic ignition and pilot flame supervision, to command the functions of a hearth appliance. Refer to Proflame 2 Section for more information.

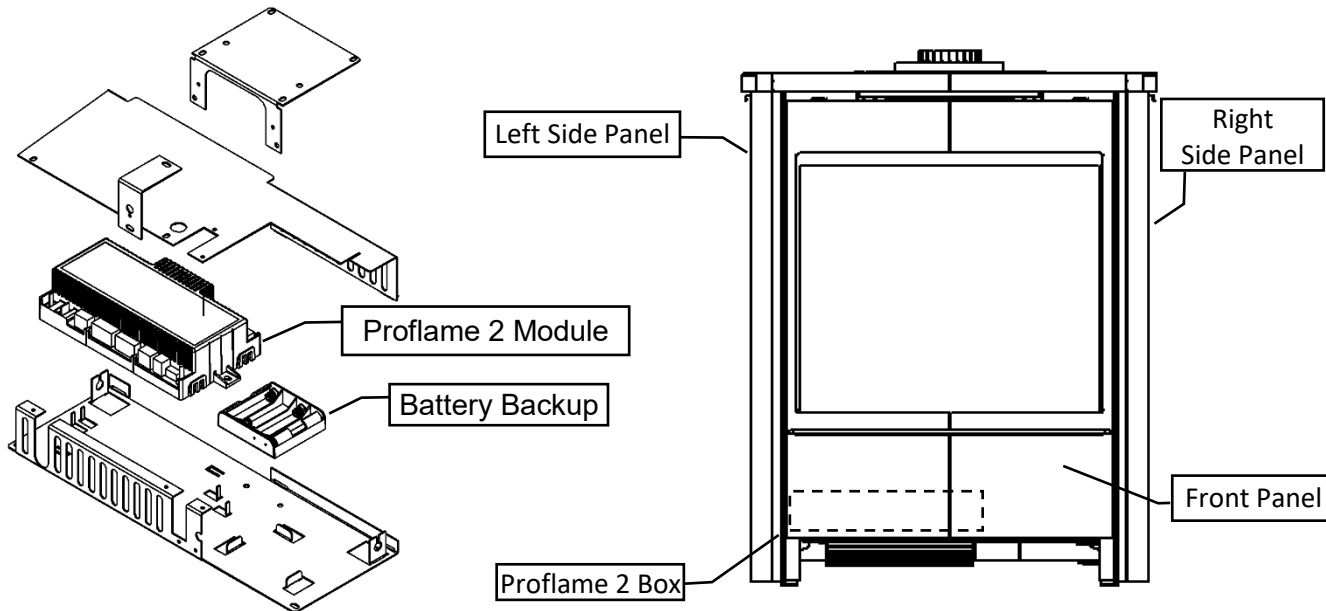

Proflame 2 Box can be inserted & removed from beneath fireplace through Left Side Panel.

**COMPONENT LOCATIONS**

(See Each Section For Connections & Wiring)

**TOP VIEW**

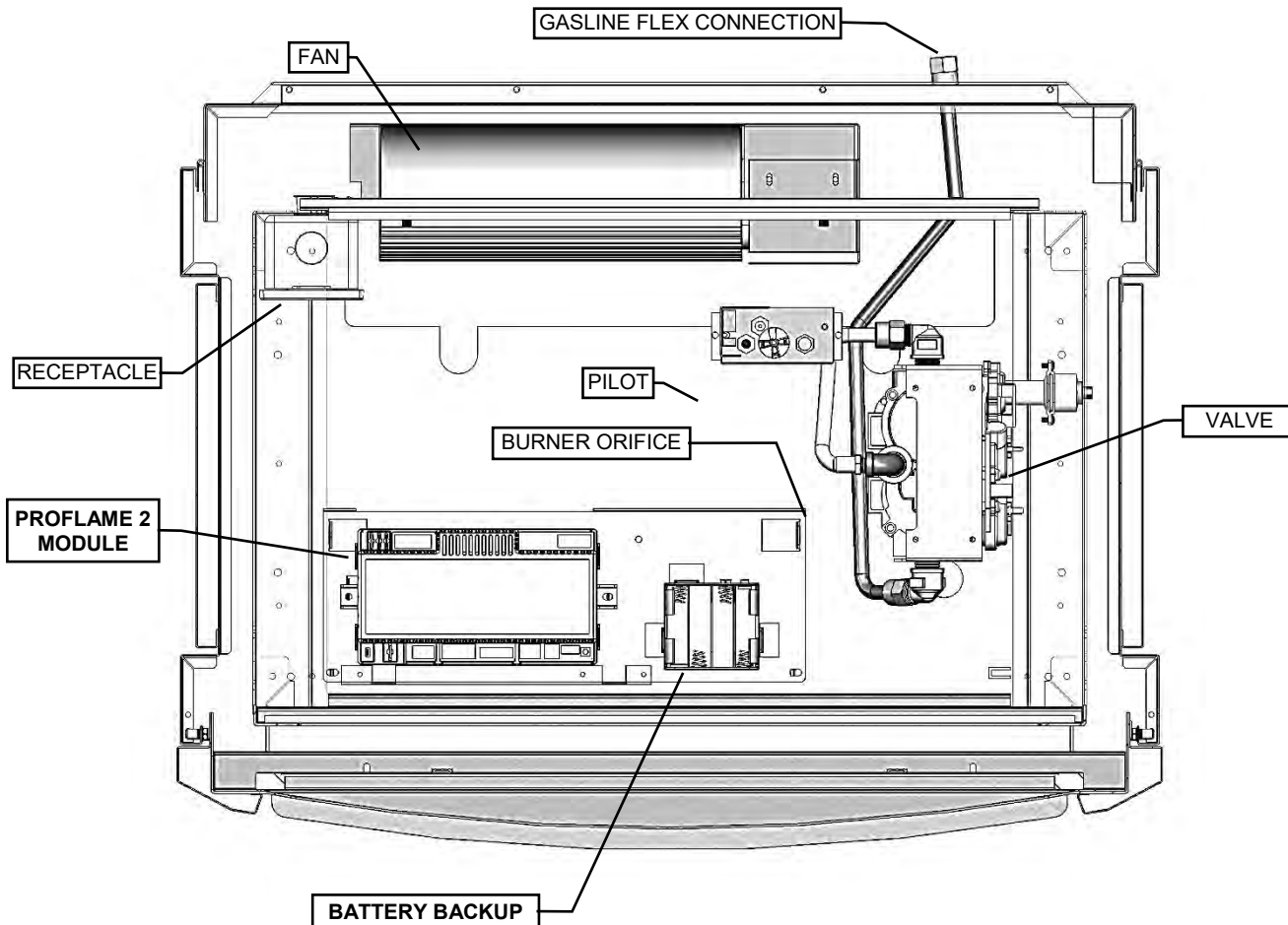

# F45LG Log Grate Installation FDV451 / MQFDV453

Contents of Kit: [1] Horizontal Grate Bar with Andiron, [1] Andiron



**Step 1:** Slide loose Andiron onto Grate Bar.

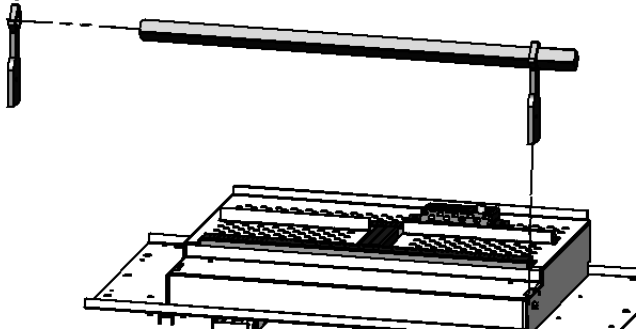

**Step 2:** Insert Andirons into slots in False Bottom.

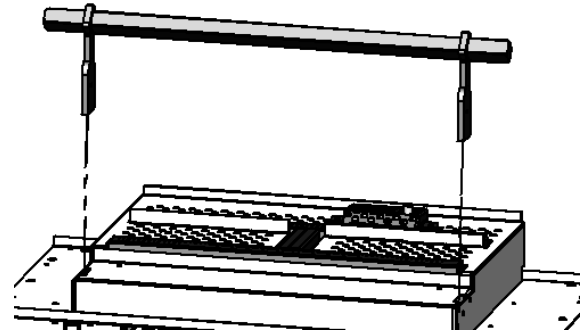

## LOGF451 – Oak Log Set

**⚠WARNING:** Failure to position the parts in accordance with these diagrams or failure to use only parts specifically approved with this appliance may result in property damage or personal injury.

**NOTE:** Lava Rock, 350 Embers, and Vermiculite are packaged with fireplace.  
Can be used with Optional **F45LG Grate Bar**.

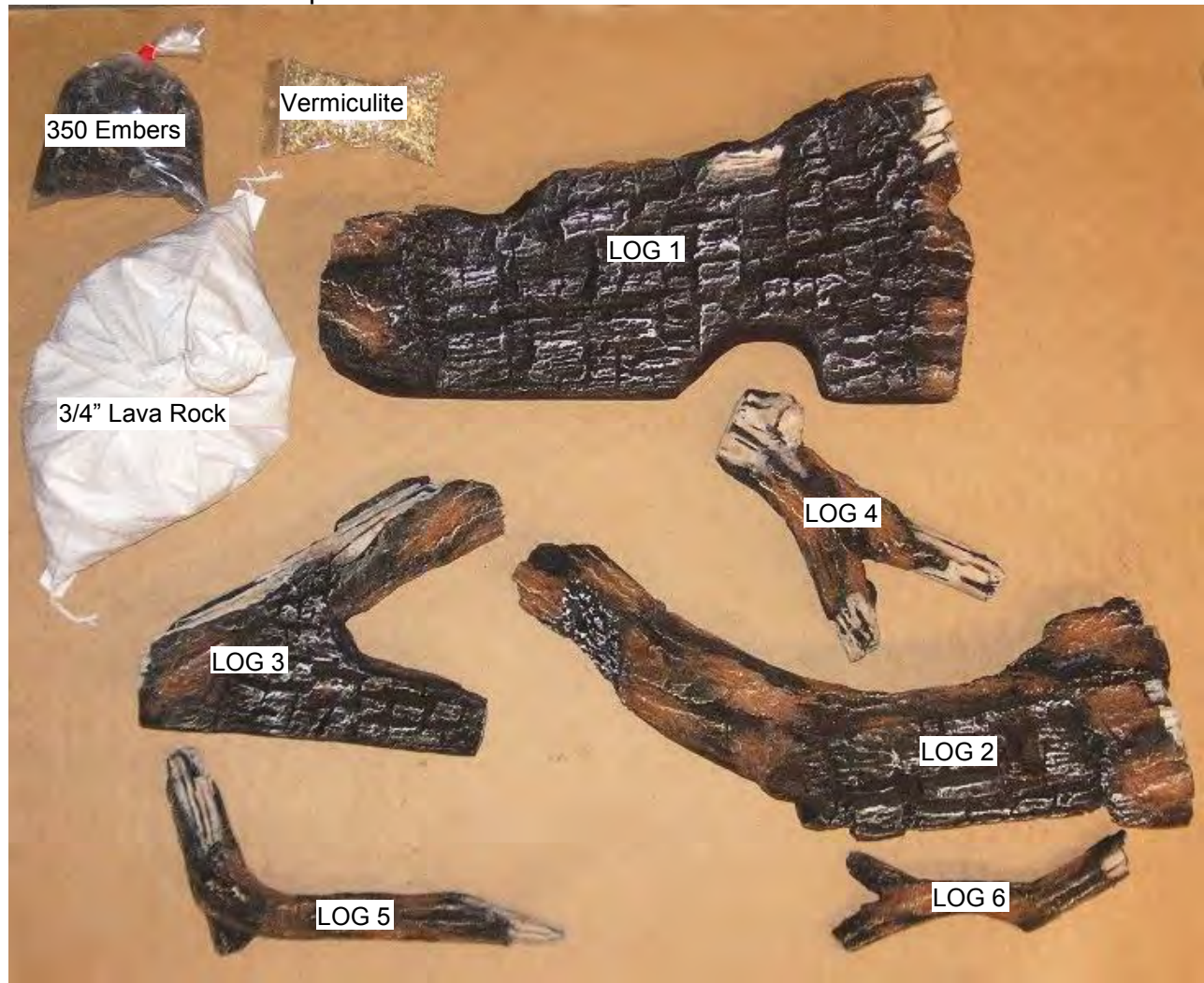

**1:** Place **LOG 1** against back wall of firebox & **Lava Rock** along sides of False Bottom.



**2:** Place **LOG 2** as shown below.



3: Place **LOG 3** and **LOG 4** as shown below.

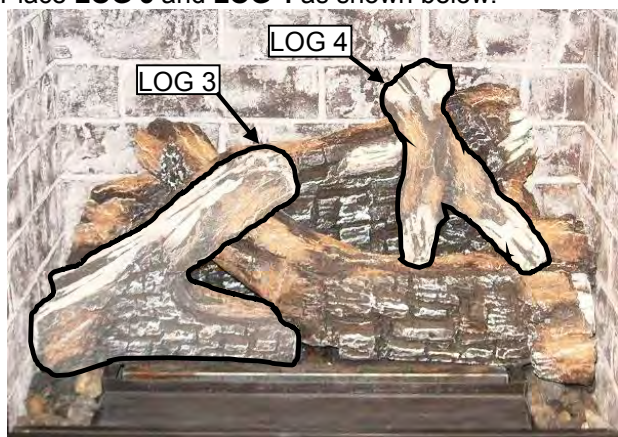

4: Place **LOG 5** and **LOG 6** as shown below.



5: Place **350 Embers** and **Vermiculite** in areas shown below.



LOGF451 Oak Logset



LOGF451 Oak Logset with optional **F45LG Grate Bar**.

## MQLOGF452 – Oak Log Set

**⚠WARNING:** Failure to position the parts in accordance with these diagrams or failure to use only parts specifically approved with this appliance may result in property damage or personal injury.

**NOTE:** Lava Rock, 350 Embers, and Vermiculite are supplied with fireplace.  
Can be used with Optional **F45LG** Grate Bar.

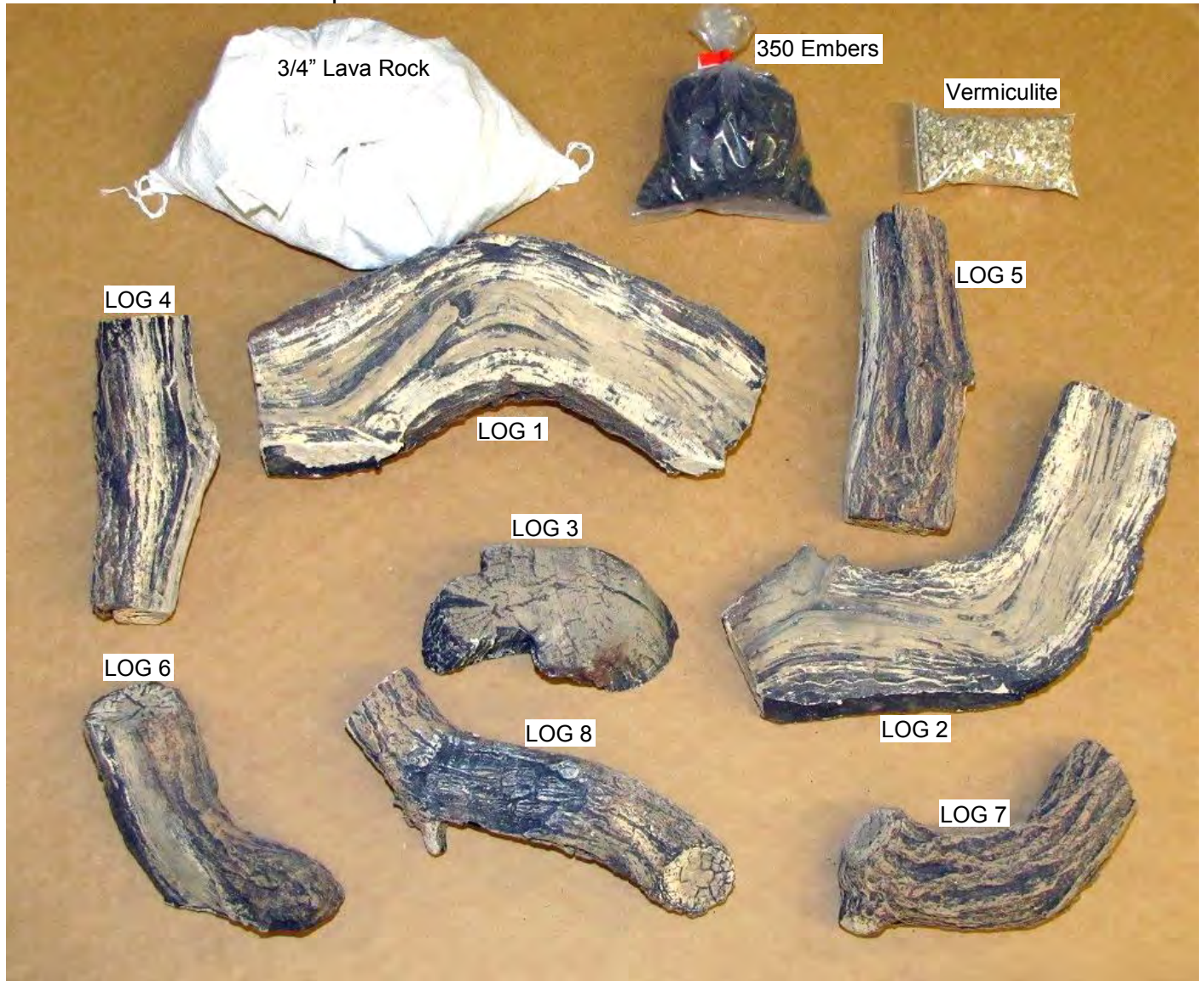

**1:** Place **LOG 1** against back wall of firebox & **Lava Rock** along sides of False Bottom.

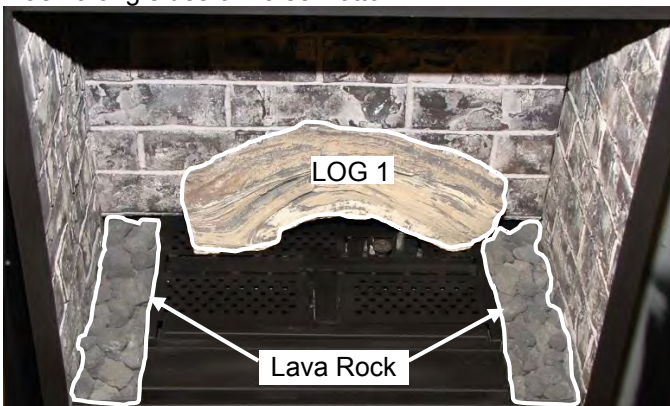

**2:** Place **LOG 2** and **LOG 3** as shown below.



3: Place LOG 4 and LOG 5 as shown below.

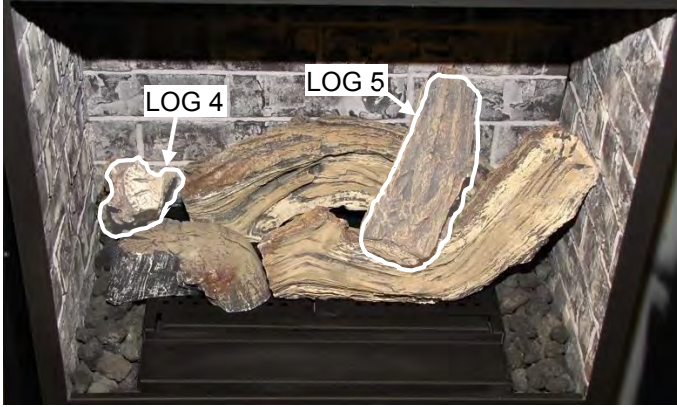

4: Place LOG 6 and LOG 7 as shown below.



5: Place LOG 2 and LOG 3 as shown below.

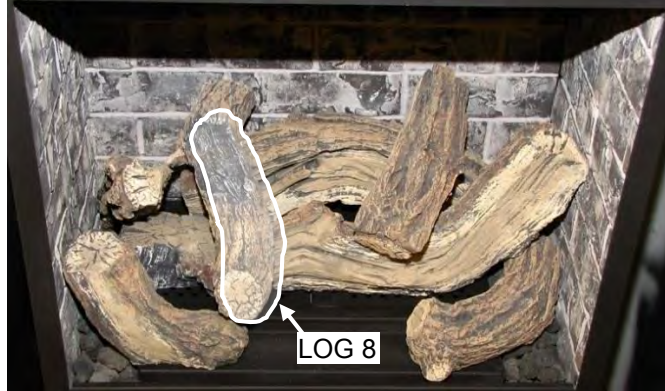

6: Place 350 Embers and Vermiculite in areas shown below.



7: If using Grate Bar, do not use LOG 6 & LOG 7, as sooting may occur.



8: Place 350 Embers and Vermiculite in areas shown below.



LOGF452 Oak Logset without Grate Bar.



LOGF452 Oak Logset with Grate Bar.

## MQLOGF453 – Driftwood Log Set

**⚠WARNING:** Failure to position the parts in accordance with these diagrams or failure to use only parts specifically approved with this appliance may result in property damage or personal injury.

**NOTE:** Lava Rock and 350 Embers supplied with fireplace.  
Can be used with Optional **F45LG** Grate Bar.



**1:** Place **LOG 1** against back wall of firebox & **Lava Rock** along sides of False Bottom.

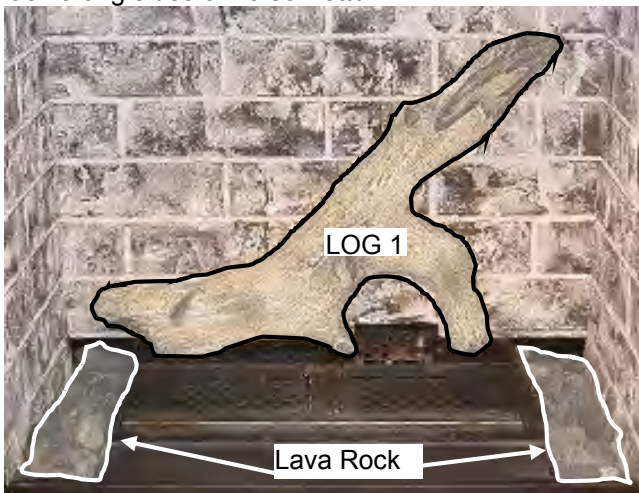

**2:** Place **LOG 2** as shown below.



3: Place **LOG 3** as shown below.



4: Place **LOG 4** behind LOG 2 on the right side.

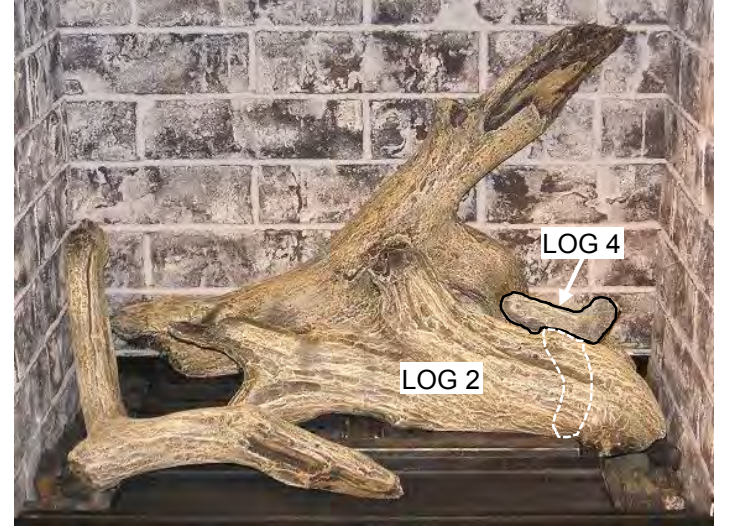

5: Place **LOG 5** as shown below.



6: Place **350 Embers and Vermiculite** in areas shown below.



MQLOGF453



MQLOGF453 with optional **F45LG** Log Grate.



Assorted size and colors. Place randomly as desired inside fireplace.



**-MUST BE USED WITH 15LBS OF GLASS MEDIA-**

Can be used with MQ Glass, MQ Ember, and / or Lava Rock. Do not place Cannonballs directly on burner ports. If sooting occurs change position of or remove affected objects. **NOTE: Not all Cannonballs will be used.**

- MQ Glass can be placed directly on Burner and on Glass Tray.
- MQ Ember can be placed directly on Burner Only.
- Lava Rock (Supplied with Base Unit) CANNOT be placed on Burner.

** NOTE**

- Pilot Area Must Not Be Covered, as delayed ignition can occur.
- Do not place Cannonballs directly on burner ports.

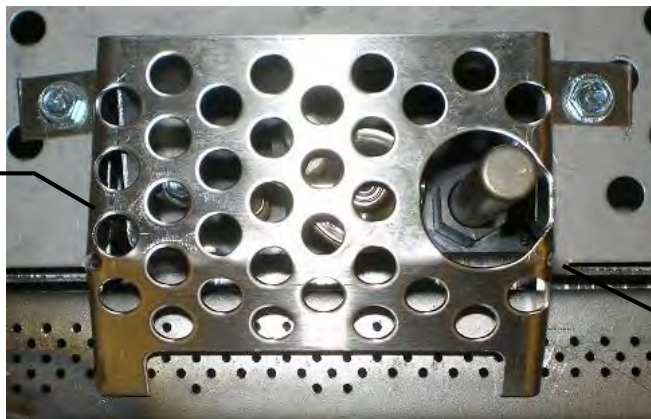

Pilot Area Must Not Be Covered

\*Pilot Shield should be visually inspected monthly for signs of deterioration due to flame exposure. Replace if necessary.

## MQ Dealer Accessories for FDV451 / MQFDV453

The following Accessories are available through MQ Dealers only.

| ACCESSORY ITEM   | DESCRIPTION                          |
|--|--------------------------------------|
| <b>MQG5W</b>   | Decorative Glass 1/2" White          |
| <b>MQG5A</b>   | Decorative Ember Glass Cobalt Blue   |
| <b>MQG5B</b>   | Decorative Ember Glass - Black       |
| <b>MQG5ZG</b>  | Decorative Glass- Zircon Glacier Ice |
| NOTE: All glass is sold in 5 pound bags.                   |                                      |
| <b>MQROCK2*</b>  | Rock Set Natural                     |
| <b>MQROCK3*</b>  | Rock Set Multi-Color                 |
| <b>MQSTONE*</b>  | Decorative Stones                    |
| <b>*THESE ITEMS MUST BE USED WITH 15LBS OF GLASS MEDIA</b> |                                      |
| <b>MQEMBER</b>   | Glowing Embers                       |

• **GLASS (MQG5W, MQG5C, MQG5A, MQG5B, MQG5ZG)**  
 If you wish to use this media evenly spread the glass embers onto the false bottom and burner. Ensure the glass embers do not excessively overlap as this will affect the flame pattern. Use care when placing glass embers near the pilot area so as not block or have the glass fall over the crossover holes from the pilot to the burner, as delayed ignition can occur.

The following types of glass are approved:

- **1/2" Ember Glass Material from American Fireglass.**  
Maximum amount: 15lbs.
  
- **Liquid Glass from Firegear.**  
Maximum amount: 15lbs.
  
- **Zircon Glacier Ice.**  
Maximum amount: 15lbs.

Use of any other glass can alter the performance of the unit and is not covered under warranty.  
 Discoloration of glass media may occur if placed on the burner, this is not covered under warranty.



Pilot Area Must **Not** Be Covered

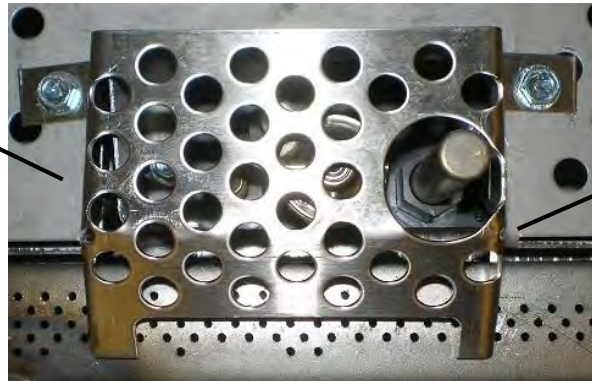

\*Pilot Shield should be visually inspected monthly for signs of deterioration due to flame exposure. Replace if necessary.

- **MQG5ZG Decorative Glass- Zircon Glacier Ice**
- Maximum amount: 15lbs.



**⚠ NOTE**

• Pilot Area Must **Not** Be Covered, as delayed ignition can occur.



## MQ Stone Decorative Stone Set



- Place Stones onto False Bottom and Burner. Do not place directly on burner ports or Pilot Area.
- Not all stones will be used on some installations.
- If sooting occurs change position of or remove affected objects.

### • MQEMBER-

- To be placed directly on Burner and Burner Ports.
- Place these glowing ember chunks randomly. May be used with or without other accessories.

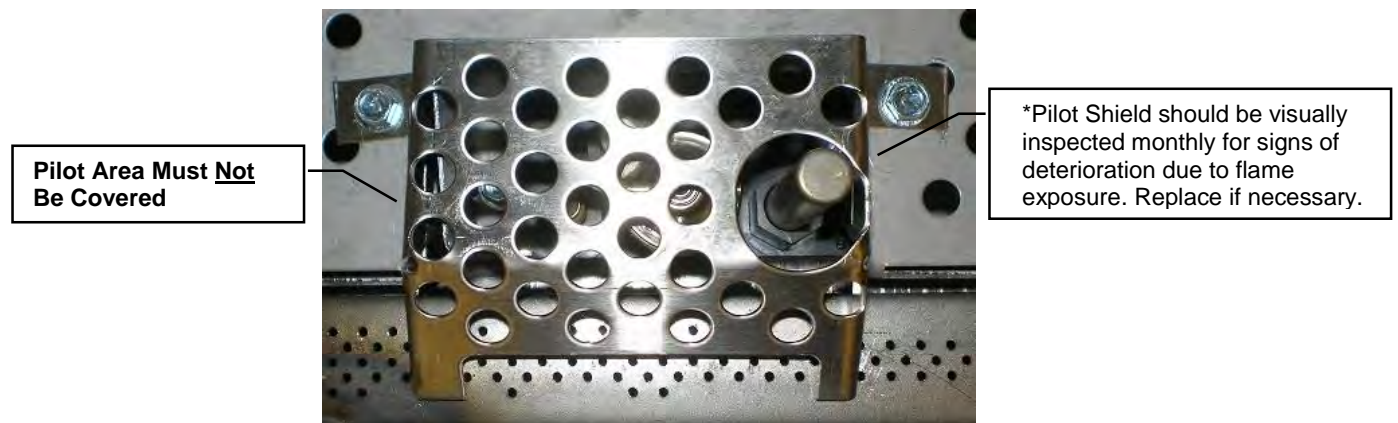

### **NOTE**

- Pilot Area Must Not Be Covered, as delayed ignition can occur.

# Millivolt System, Lighting, and Burner Control

## FOR YOUR SAFETY READ BEFORE LIGHTING

**WARNING:** If you do not follow these instructions exactly, a fire or explosion may result causing property damage, personal injury or loss of life.

### BEFORE LIGHTING

- |  |  |
|--|--|
| <p>A This appliance has a pilot which must be lighted by hand. When lighting the pilot, follow these instructions exactly.</p> <p>B Smell all around the appliance area for gas. Be sure to smell next to the floor because some gas is heavier than air and will settle on the floor.</p> | <ul style="list-style-type: none"> <li>• Immediately call your gas supplier from a neighbour's phone. Follow the gas supplier's instructions.</li> <li>• If you cannot reach your gas supplier, call the fire department.</li> </ul> <p>C Use only your hand to push or turn the gas control knob. Never use tools. If the knob will not push in or turn by hand, don't try to repair it. Call a qualified technician. Force or attempted repair may result in a fire or explosion.</p> <p>D Do not use the appliance if any part has been under water. Immediately call a qualified service technician to inspect the appliance and to replace any part of the control system which has been under water.</p> |
|--|--|

### WHAT TO DO IF YOU SMELL GAS

- Do not try to light an appliance.
- Do not touch any electrical switch; do not use any phone in your building.

## LIGHTING INSTRUCTIONS

- |  |   |
|--|---|
| <ol style="list-style-type: none"> <li>1. Stop! Read the safety information above this label.</li> <li>2. Set the thermostat to lowest setting.</li> <li>3. Turn off all electrical power to the appliance.</li> <li>4. Locate valve under the burner assembly.</li> <li>5. If the control knob is not already in the off position, i.e. the word "OFF" in the 9 o'clock position, then push in the gas control knob slightly and turn ⤵ clockwise to "OFF". NOTE: Knob cannot be turned from "PILOT" to "OFF" unless knob is pushed in slightly. Do not use force.</li> <li>6. Wait five [5] minutes to clear out any gas. If you then smell gas. STOP! Follow "B" in the safety information above on this label. If you don't smell gas then go to the next step.</li> <li>7. Now push in the control knob slightly and turn ⤴ counter-clockwise to the "PILOT" position.</li> <li>8. Push in the control knob all the way and hold it. With the other hand push in the red igniter button until you hear a click. Now observe closely the pilot burner located on the rear center-left hand side of the main burner.</li> </ol> | <p>If a flame has appeared then continue to depress the control knob for 20 seconds. If the flame did not appear then continue to depress the red igniter button every 5 seconds until a flame is established. NOTE: If after 30 seconds a flame has not yet been established then turn the control knob back to the off position and repeat steps 5, 6 &amp; 7.</p> <ol style="list-style-type: none"> <li>9. Once the pilot has been established hold the control knob in the depressed position for approximately 25 seconds before releasing. If the flame goes out then repeat steps 7 and 8.             <ul style="list-style-type: none"> <li>• If the knob does not pop up when released, stop and immediately call your service technician or gas supplier.</li> <li>• If the pilot will not stay lit after several tries, turn the gas control to "OFF" and call your service technician.</li> </ul> </li> <li>10. Now turn the control knob to the "ON" position. The burner will not light unless the wall switch thermostat or remote control is turned "ON" or in the case of the thermostat there is a call for heat.</li> <li>11. Close the access door and turn all electrical power back to the appliance.</li> <li>12. The pilot must be turned off when the unit is not in use.</li> </ol> |
|--|---|

## TO TURN OFF THE APPLIANCE

- |  |  |
|--|--|
| <ol style="list-style-type: none"> <li>1. Set the thermostat to lowest setting.</li> <li>2. Turn off all electric power to the appliance if service is to be performed.</li> <li>3. Open the control access door.</li> </ol> | <ol style="list-style-type: none"> <li>4. Push in the gas control knob slightly and turn ⤵ clockwise to the "OFF" position. Do not force.</li> <li>5. Replace control access panel.</li> </ol> |
|--|--|

**NOTE:** Only one on/off device (manual on/off, remote control, or hard wired thermostat) should be connected to the appliance at any one time, this is most important when installing an insert or stove as the on/off rocker switch is installed at the factory.

Recommended Maximum Lead Length (Double Wire)  
When Using Wall Switch or Thermostat

| Wire Size | Max. Length   |
|-----------|---------------|
| 14ga      | 100ft [30.4m] |
| 16ga      | 64ft [19.5m]  |
| 18ga      | 40ft [12.1m]  |
| 20ga      | 25ft [7.6m]   |
| 22ga      | 15ft [4.5m]   |

**CAUTION: DO NOT WIRE 120V POWER TO MILLIVOLT SWITCHES OR THERMOSTAT.**

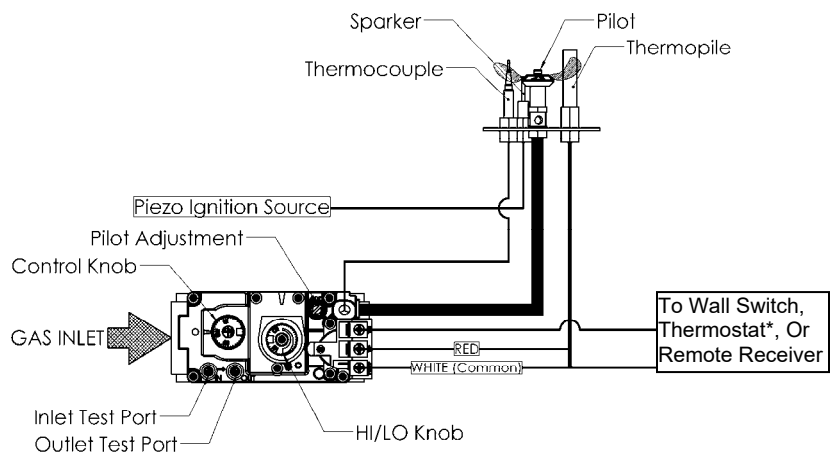

\*In the U.S.A. Thermostats are not permitted for Vented Gas Fireplaces (ANSI Z21.50b-2009 -Decorative).

## Burner System Maintenance FDV451 / MQFDV453

It is recommended to annually inspect and clean the Burner System to prevent malfunction and / or sooting. This operation should be performed by your dealer or a qualified technician.

### -CAUTION-

Before servicing the burner system ensure that the gas supply is turned OFF and disconnect all electrical connections to the appliance. Allow the appliance to cool to room temperature. Note that the pilot assembly may be hot in an intermittent or standing-pilot system—even if the main burner was never on. Exercise caution when working within the area.

**-ALL WORK SHOULD BE PERFORMED BY A QUALIFIED AND CERTIFIED TECHNICIAN-**

### Monthly Flame Inspection

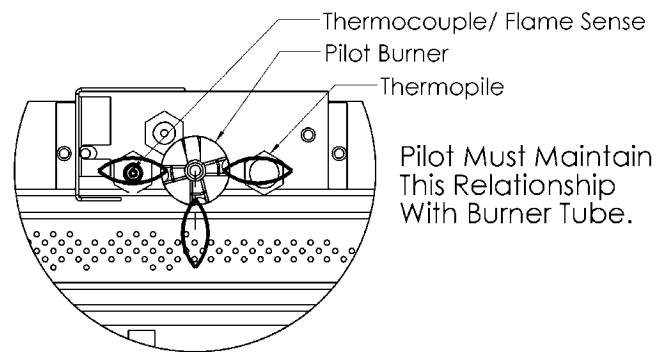

It is recommended to turn on the unit at least once a month and inspect the flame pattern to ensure there are no problems with the burner tube (Flame should appear similar to the above picture).

The pilot flame should also be inspected monthly to ensure proper operation.



**Pilot Must Maintain This Relationship With Burner.**

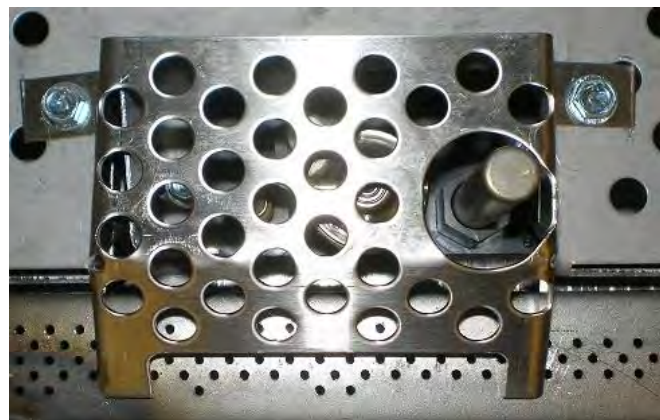

**Pilot Shield Area Must Not Be Covered With Media.**

\*Pilot Shield should be visually inspected monthly for signs of deterioration due to flame exposure. Replace if necessary.

# Restrictor Baffle Setting for Gas Conversions **FDV451 / MQFDV453**

The Restrictor Baffle must be set correctly in order for the appliance to function properly.

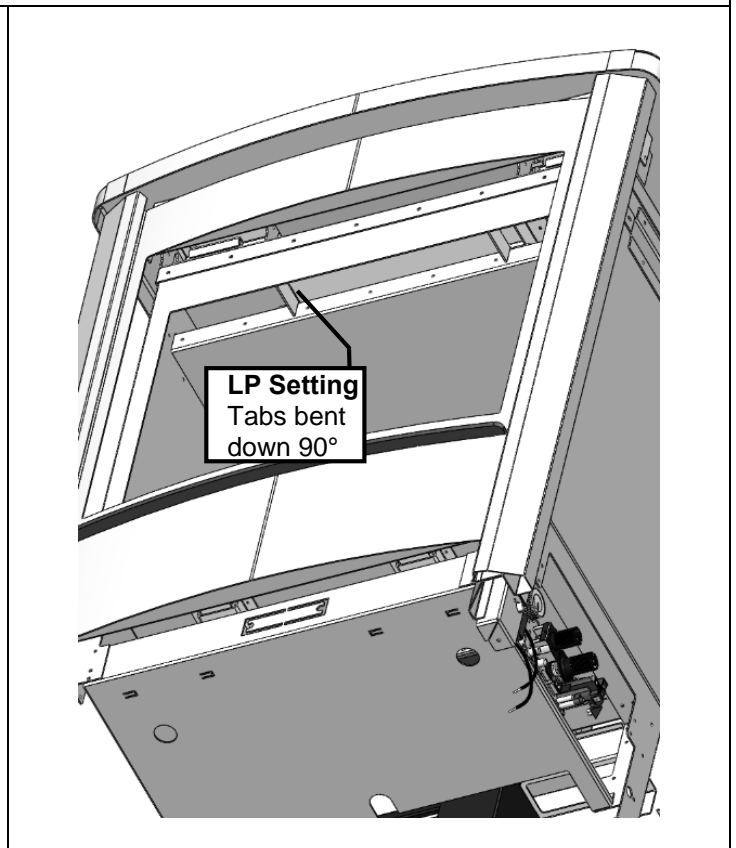
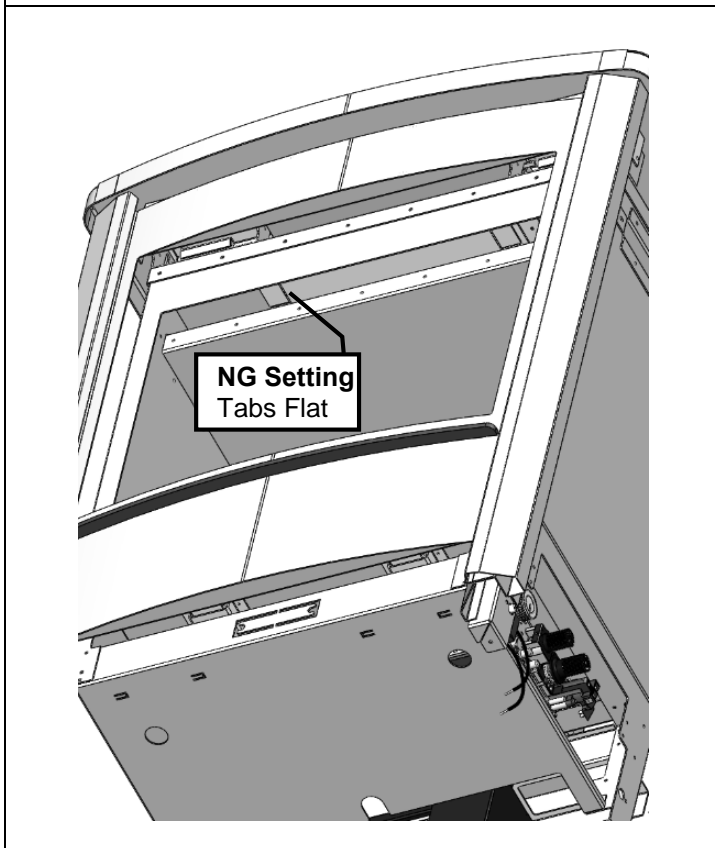
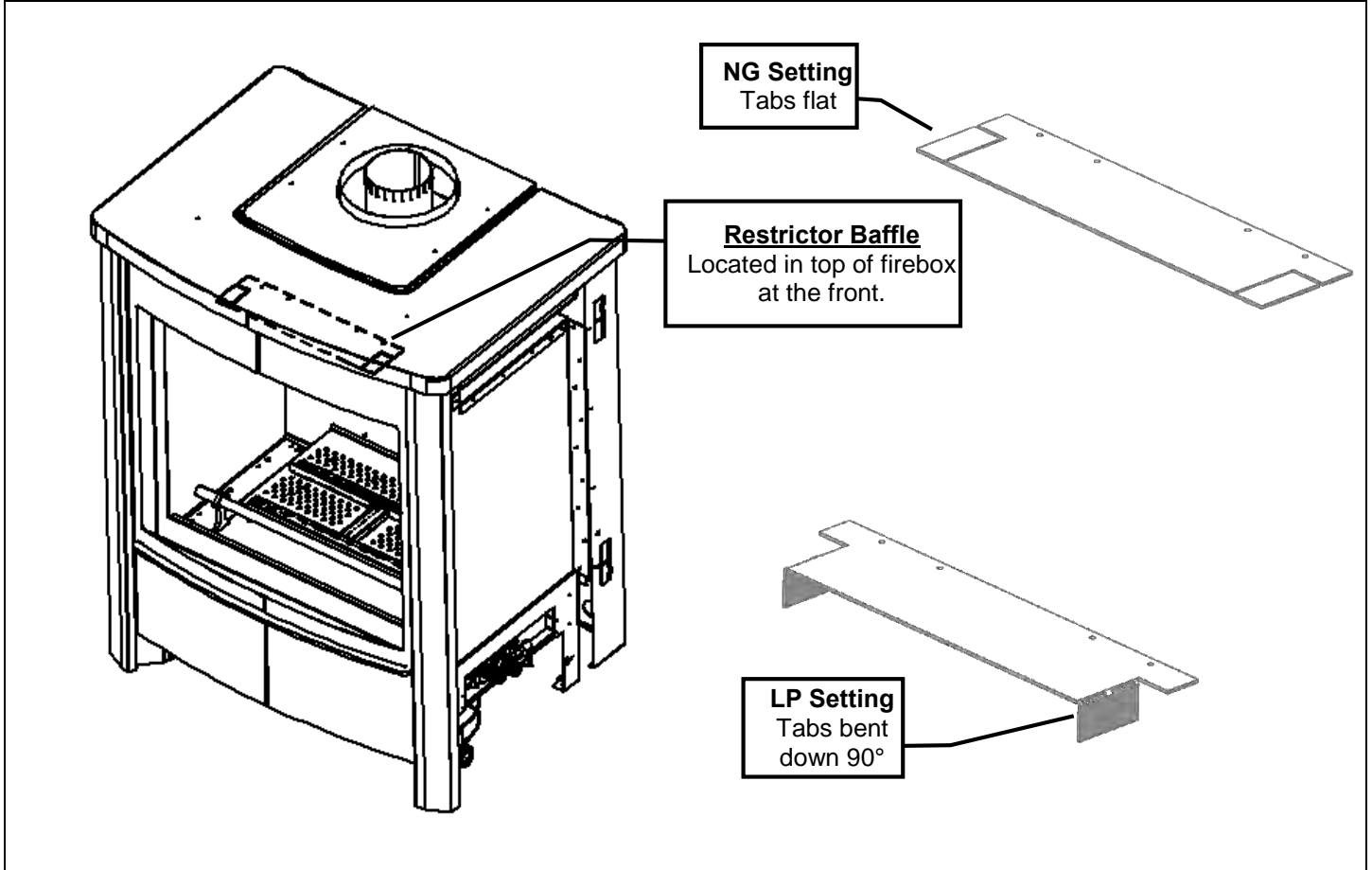

# FDV451 / MQFDV453 Gas Conversion Part A

Models: FDV451N, FDV451NE, FDV451LP, FDV451LPE, MQFDV453N, MQFDV453NE, MQFDV453LP, MQFDV453LPE

| Kit Number  | Description                  | Pilot Orifice                | Burner Orifice<br>Brass (1000-255) | Brass Nipple       | Air Shutter | Hi/Lo Regulator            |
|-------------|------------------------------|------------------------------|------------------------------------|--------------------|-------------|----------------------------|
| 450DV-CKLP  | LP Conversion<br>-Millivolt- | 1001-P167SI<br>#30 (977.167) | #50                                | 1000-253<br>Closed | Fully Open  | 1001-P202SI<br>(0.907.202) |
| 450DV-CKNG  | NG Conversion<br>-Millivolt- | 1001-P165SI<br>#51 (977.165) | #32                                | 1000-253<br>Closed | 1/4"        | 1001-P201SI<br>(0.907.201) |
| 450DV-CKLPI | LP Conversion<br>-IPI-       | 1001-P168SI<br>#35 (977.168) | #50                                | 1000-253<br>Closed | Fully Open  | 1002-P014SI<br>(0.907.014) |
| 450DV-CKNGI | NG Conversion<br>-IPI-       | 1001-P166SI<br>#62 (977.166) | #32                                | 1000-253<br>Closed | 1/4"        | 1002-P016SI<br>(0.907.016) |

**IMPORTANT:** Always check for gas leaks with a soap and water solution. **DO NOT USE OPEN FLAME FOR LEAK TESTING.**

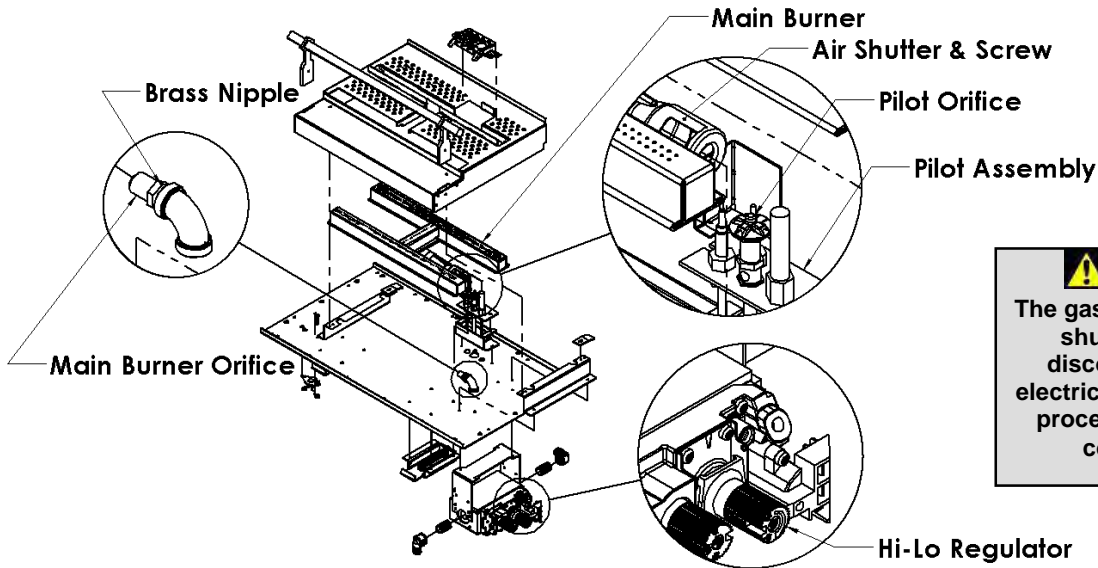

**⚠ Caution:**  
The gas supply shall be shut off prior to disconnecting the electrical power, before proceeding with the conversion.

1. The Burner Tube must be removed from the Burner Pan Assembly (See **Burner Tube Removal**). Adjust the Air Shutter to the correct Primary Air setting as specified in the manual or on the label plate. To adjust the Primary Air setting, loosen screw on the side of the Air Shutter and rotate to the correct opening using a drill bit or tape measure. Retighten screw.
2. Remove the Main Orifice using a 1/2" wrench and replace with the new Conversion Orifice which came with the Conversion Kit.
3. Replace the Burner Tube. Install the new Pilot Orifice (See **Pilot Conversion**) and Hi/Lo valve regulator by following instructions supplied with the Conversion Kit.



Refer to "**Gas Specifications Chart**" for inlet pressures and input ratings. Clock meter to verify input rate. Place conversion label as close to converted gas control as possible. Refer to lighting instructions to verify the normal operating sequence of the ignition system.

## ⚠ -Warning-

This conversion kit shall be installed by a qualified service agency in accordance with the manufacturer's instructions and all applicable codes and requirements of the authority having jurisdiction. If the information in these instructions is not followed exactly, a fire, explosion or production of carbon monoxide may result causing property damage, personal injury or loss of life. The qualified service agency is responsible for the proper installation of this kit. The installation is not proper and complete until the operation of the converted appliance is checked as specified in the manufacturer's instructions supplied with the kit.

## Gas Conversion for Top Convertible Pilot – Part B (series 0190XYZ)



Instructions for converting SIT 190 series pilot burner injector from NG to LPG and from LPG to NG only. This information should be considered as supplemental to the Appliance Manufacturer's Instructions.

### WARNING!

The installation of this conversion kit must only be undertaken by a qualified and certified gas appliance installer.

1. Shut-off the gas supply to the appliance.
2. Allow the pilot burner to cool to room temperature.

**WARNING: Touching a hot pilot burner can result in injury.**

3. The pilot hood is held in place by spring. First remove the spring, then remove the hood by pulling it up from the pilot bracket (fig. 1).
4. Insert a 5/32" or 4 mm Allen wrench into the hexagonal key-way of the injector (fig. 2), and rotate it counter-clockwise until it is free of the injector journal.
5. Verify that the new injector is proper for the application. The injector size is stamped on the side of the injector near the top. LPG injectors have a groove machined around their circumference near the top, while NG injectors do not have a groove (fig. 4). Refer to the Appliance Manufacturer's instruction sheet for the proper injector size.
6. Insert the Allen wrench into the end of the injector. Then, insert the injector into injector journal, and rotate the injector clockwise until a torque of 9 lbf in (1.0 Nm) is achieved.
7. First replace the pilot hood by aligning the tab on the base of the hood with the slot in the side of the pilot journal, and push the hood down, onto the pilot bracket (fig. 3). The hood must sit squarely on the bracket for proper operation. Then replace the spring by pushing it on his seat (fig.3). Check to insure that the hood is properly seated onto the pilot bracket and that the spring is properly inserted onto his seat.
8. Restore the gas supply to the appliance, and ignite the pilot burner. Verify proper ignition and operation.



fig. 1

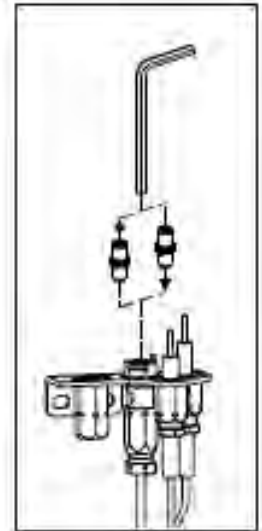

fig. 2



fig. 3

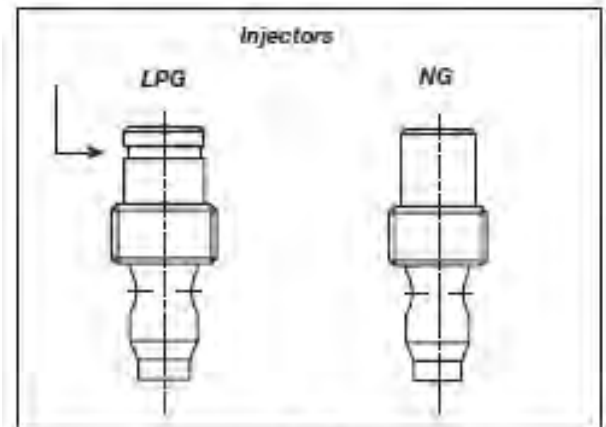

fig. 4

### WARNING!

This conversion kit must ONLY be applied as part of a conversion kit supplied by the APPLIANCE MANUFACTURER for the specific appliance, and type of gas, being converted.



# SIT GROUP

www.sitgroup.it



# installation instructions

7.252.136

## 820 NOVA mV

### Modulating Conversion Kit



**WARNING!**

The installation of this conversion kit must only be undertaken by a qualified and certified gas appliance installer.

**MODULATING PRESSURE REGULATOR CONVERSION KIT INSTALLATION OR REPLACEMENT INSTRUCTIONS.**

- 1 Turn control knob to the OFF position, and shut off the gas supply to the valve.
- 2 Using a Torx T20, or slotted screwdriver, remove and discard the three pressure regulator mounting screws (A), pressure regulator tower (B), and the spring and diaphragm assembly (C).  
(If applicable)
- 3 Insure that the rubber gasket (D) is properly positioned and install the new modulating pressure regulator assembly to the valve using the new screws (E) supplied with the kit. Tighten screws securely.  
(Reference torque = 25 In.Lb.)
- 4 Install the enclosed identification label (F) to the valve body where it can be easily seen.
- 5 Apply gas to system and re-light appliance according to manufacturers instructions.
- 6 With the main burner "ON", test the new pressure regulator assembly for leaks using a soap solution.
- 7 Relight the main burner in both the HI and LO positions, and verify proper burner ignition and operation.

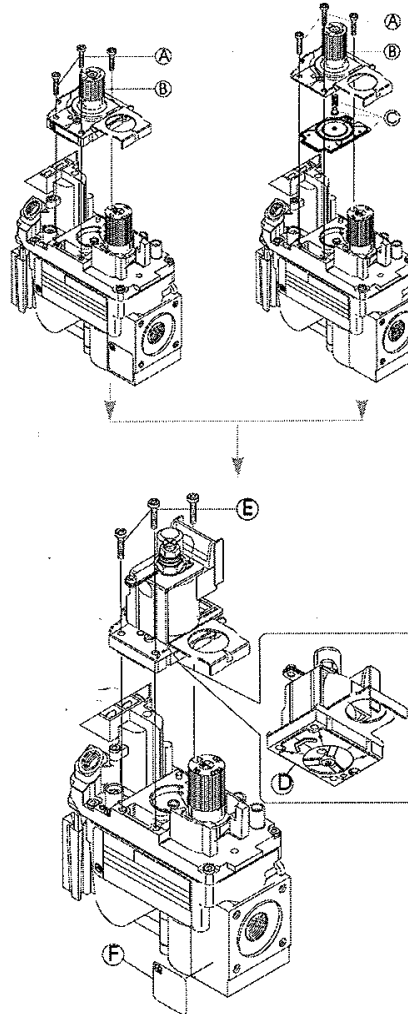

**WARNING!**

This modulating conversion kit must ONLY be applied as part of a conversion kit supplied by the APPLIANCE MANUFACTURER for the specific appliance, and type of gas, being converted.

**INSTALLER NOTICE.** These instructions must be left with appliance.



**SIT Group**

# FDV451 / MQFDV453 Burner Removal

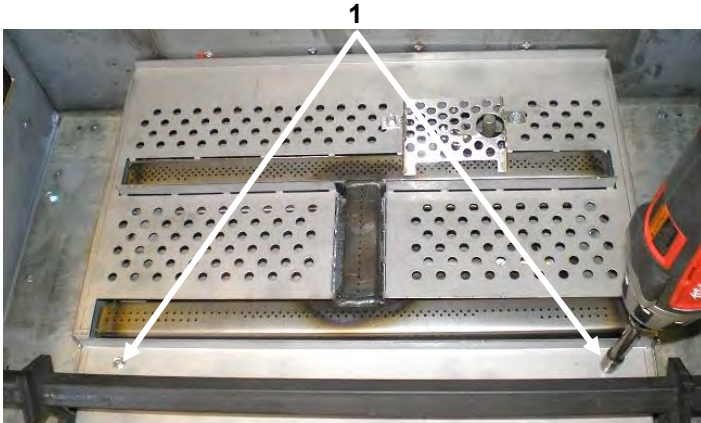

1. Remove [2] DT Screws behind Grate and lift False Bottom Assembly out of firebox.

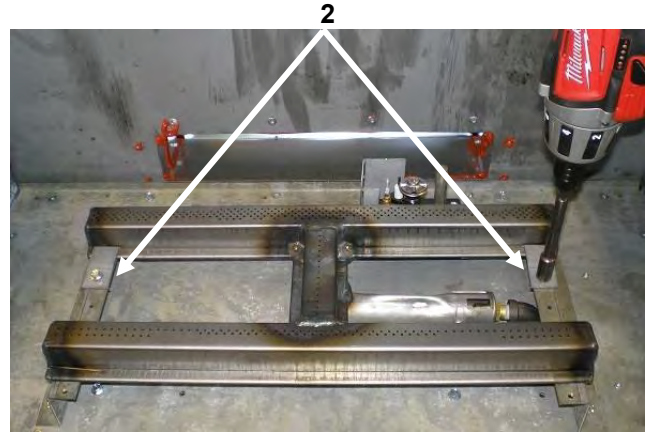

2. Loosen Burner Hold Downs.

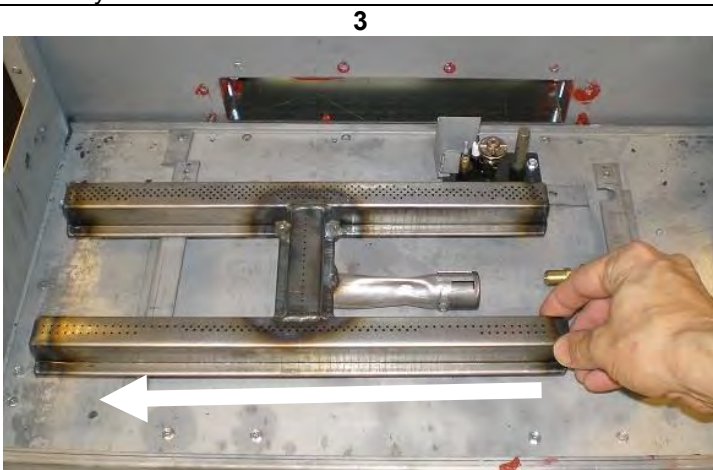

3. Slide H Burner to the left.

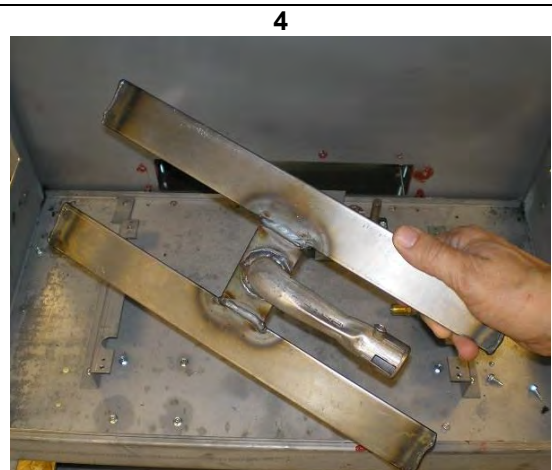

4. Remove Burner.

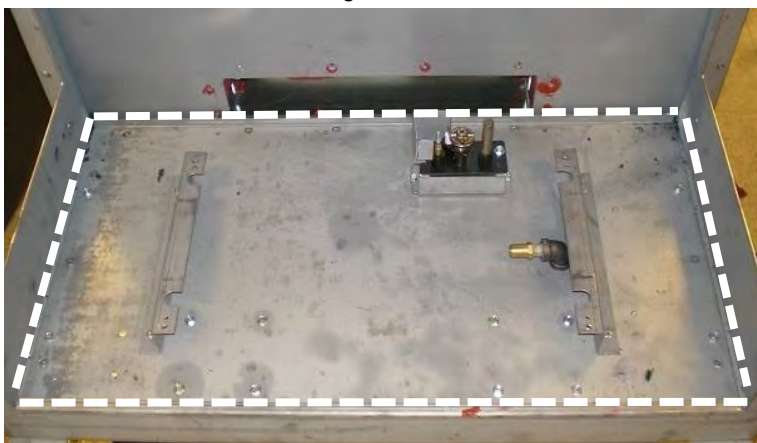

5. To remove entire Burner Pan, remove [16] DT Screws around perimeter of pan.

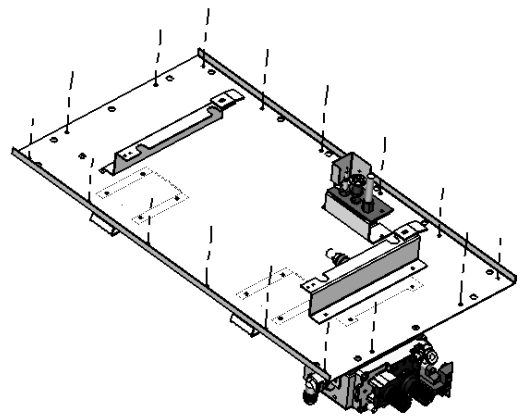

Installation is the reverse of these steps. Ensure that the mounting surface is clean.

**Use fresh Black Mill Pac to reseal the burner pan.**

## **WARNING**

Turn off Unit and allow to cool before cleaning. Only a Qualified service technician should service and repair this appliance.

# IPI Electronic Ignition System

## Overview

The IPI system is an advanced burner controller that provides you with the option of having either a Standing-Pilot, or an intermittent igniting system. This alternating mode is controlled by the CPI/IPI Switch (Continuous Pilot Ignition/Intermittent Pilot Ignition) located on the IPI System Box. The difference between a Standing-Pilot and an Intermittent-Pilot is in whether the pilot stays lit or shuts off:

In Standing-Pilot, the pilot assembly is lit by the IPI Main Module and continues to stay lit until 1) the CPI/IPI Switch is switched to the IPI position; 2) a loss of electrical power (battery and AC source), 3) the flame sensor loses its signal, 4) the fuel supply discontinues, or 5) the IPI Main Module malfunctions.

In the Intermittent-Pilot mode, the pilot shuts off when the appliance is not in use. The advantage of this mode is that fuel is not consumed when the fireplace is not operating.

NOTE: In some jurisdictions Intermittent-Pilot is required. That means the pilot cannot remain lit when the appliance is not operating.

## Components

The core of the IPI system is the Main Module and the IPI Valve. With these two components the system is able to operate a gas fireplace. There are also other components available to complement the IPI system.

**IPI System Cover:** Is essential in keeping the components at their proper operating temperatures. **DO NOT OPERATE THE APPLIANCE WITHOUT THIS COVER.**

**Modulating Servo Motor:** Is an add-on valve component that permits HI/LO functionality to be controlled by the remote. Contrary to this feature is a Manual HI/LO Control Knob. The Modulating Servo Motor requires the Remote system to be present.

**Backup Battery Pack:** This component permits the IPI system to operate without the need for an external AC Adapter power source. The advantage to using the battery backup is that in the case of a power failure, the appliance is still operable.

**NOTE:** In certain instances the IPI Main Module requires resetting. This can occur if the system is unable to ignite the pilot or the main burner in the allotted time period. The IPI is programmed to lockout all commands. To reset this lockout you must deplete the system of all electrical power. This means to remove the batteries from the Battery Pack, remove the batteries from the Remote Receiver (if applicable), and disconnect the AC Adapter from the system. Leave the power off for approximately 25 seconds to clear its lockout.

**Remote Receiver:** This component provides the capability of controlling the appliance with a wireless remote transmitter.

### Standing Pilot Mode for Colder Climates (Below Freezing)

For IPI models it may be necessary to set the appliance to Standing Pilot mode to maintain heat in the cavity. The purpose of this procedure is to prevent cold air from penetrating the chimney and then onto the living space. Therefore, when the internal temperature is slightly elevated the fireplace is able to freely exhaust its combustion and hence making it easier to startup.

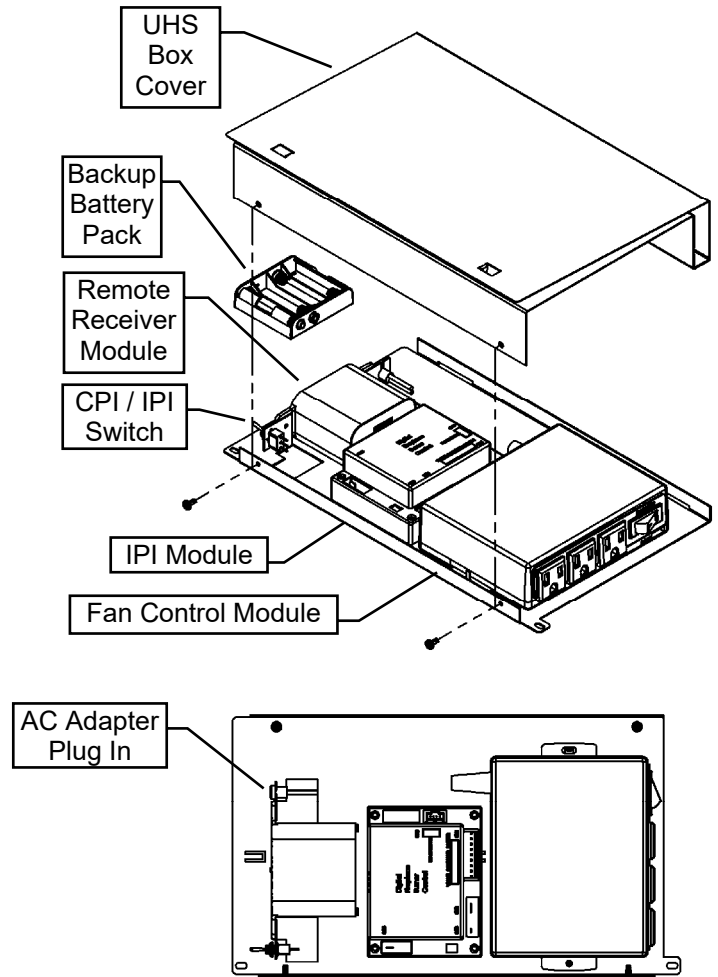

## -Remote Control Operation-

The Proflame GTM is configured to control the on/off main burner operation, its flame levels, and provides on/off and Smart thermostatic control of the appliance.

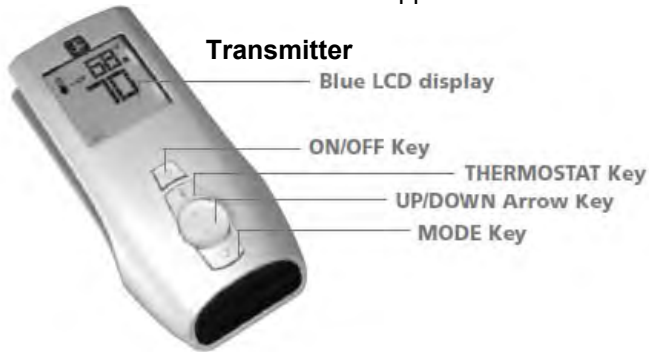

### Transmitter

The Transmitter is powered by 3 AAA type batteries. A Mode Key is provided to Index between the features and a Thermostat Key is used to turn on/off or index through thermostat functions

### Remote Receiver

The Receiver connects directly to the gas valve and stepper motor with a wiring harness. The Receiver is powered by 4 AA type batteries. The Receiver three position slider switch can be set to one of three positions: ON (Manual Override), Remote (Remote control) or Off.

### Initializing the System for the first time

Install 4 AA batteries into the receiver battery bay. Install 3 AAA type batteries in the Transmitter battery bay. Place the 3 position slider switch in the "Remote" position. Insert the end of a paper clip into the hole marked "PRG" on the Receiver front cover. The Receiver will "beep" three (3) times to indicate that it is ready to synchronize with a Transmitter. Push the On button. The Receiver will "beep" four times to indicate the Transmitter's command is accepted. The system is now initialized.

### Temperature indication Display

With the system in the "OFF" position, press the Thermostat Key and the Mode Key at the same time. Look at the LCD screen on the Transmitter to verify that a C or F is visible to the right of the Room Temperature display.

### Turn the Appliance On or Off

Press the ON/OFF Key on the Transmitter

### Remote Flame Control

The Proflame GTM has six (6) flame levels. Pressing the Down Arrow Key once will reduce the flame height by one step until the flame is turned off. The Up Arrow Key will increase the flame height each time it is pressed. If the Up Arrow Key is pressed while the system is on but the flame is off, the flame will come on in the high position.

**NOTE:** The Remote Receiver module can also be located outside of the appliance to a maximum of 6ft away installed in a certified deep wall switch electrical box (2-3/4" depth). For this configuration an extension wiring harness (P/N: 1001-P904S1) is required.

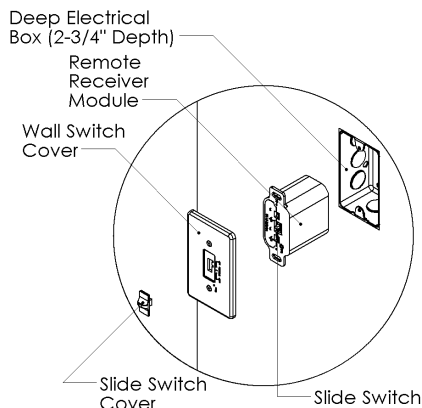

### Room Thermostat ( Transmitter Operation)

The Remote Control can operate as a room thermostat. To activate this function, press the Thermostat Key. The LCD display on the Transmitter will change to show that the room thermostat is "ON" and the set temperature is now displayed. To adjust the set temperature, press the Up or Down Arrow Keys until the desired set temperature is displayed on the LCD screen of the Transmitter.

### Smart Thermostat (Transmitter Operation)

The Smart Thermostat function adjusts the flame height in accordance to the difference between the set point temperature and the actual room temperatures. As the room temperature gets closer to the set point the Smart Function will modulate the flame down. To activate this function, press the Thermostat Key until the word "SMART" appears to the right of the temperature bulb graphic. To adjust the set temperature, press the Up or Down arrow Keys until the desired set point temperature is displayed.

### Key Lock Function

This function will lock the keys to avoid unsupervised operation. To activate this function, press the MODE and the UP Arrow Key at the same time. To de-activate this function, press the MODE and the UP Arrow Key at the same time.

### Low Battery Detection

**Transmitter** - When the Transmitter batteries are low, a Battery Icon will appear on the LCD display of the Transmitter.  
**Receiver** - When the Receiver batteries are low, No "beep" will be emitted from the Receiver when it receives an On/Off command from the Transmitter. When the batteries are replaced the "beep" will be emitted from the Receiver when the ON/OFF Key is pressed (See Initializing the System for the first time).

### Manual Bypass Of The Remote System

If the batteries of the Receiver or Transmitter are low or depleted, the appliance can be turned on manually by sliding the three position slider switch on the Receiver to the ON position. This will bypass the remote control feature and the appliance main burner will come on if the gas valve is in the "On" position.

\*In the U.S.A. Thermostats are not permitted for Vented Gas Fireplaces (ANSI Z21.50b-2009 -Decorative).,

# IPI Electronic Ignition Parts List – Standard System

| ITEM NO. | PART NO.     | DESCRIPTION                             |
|----------|--------------|---|
| 1        | 1006-P002si  | Valve IPI Hi/Lo NG                      |
|          | 1006-P003si  | Valve IPI Hi/Lo LP                      |
| 2        | *1002-P047si | Pilot Assembly-LP -24" Wire             |
|          | *1002-P033si | Pilot Assembly-NG -24" Wire             |
| 3        | 1002-P017si  | Spark Electrode (with wire)             |
|          | *1002-P119si | Spark Electrode (with wire- 35" Length) |
| 4        | 1002-P903si  | Electrode Flame Sensor                  |
|          | *1002-P910si | Electrode Flame Sensor (35" Length)     |
| 5        | 1002-P302si  | IPI Ignition Board                      |
| 6        | 1002-P850si  | AC Wall Adapter                         |
| 7        | 1002-P12BH   | Battery Pack                            |
| 8        | 1002-P912si  | Wiring Harness                          |
| 9        | 1001-P166si  | Orifice Pilot -NG#62                    |
|          | 1001-P168si  | Orifice Pilot -LP#35                    |
| 10       | 1002-P013si  | Stepper Motor -NG                       |
|          | 1002-P012si  | Stepper Motor -LP                       |
|          | 1002-P016si  | Hi/Lo Regulator -NG                     |
|          | 1002-P014si  | Hi/Lo Regulator -LP                     |

\*Models ZRB46E / MQRB4436E / MQRB5143E / MQRB6961E  
Longer (35") Wire length is required for these units.

**Proflame System**  
**Configuration: Manual Hi/Low**  
**Simplified Wire Diagram**

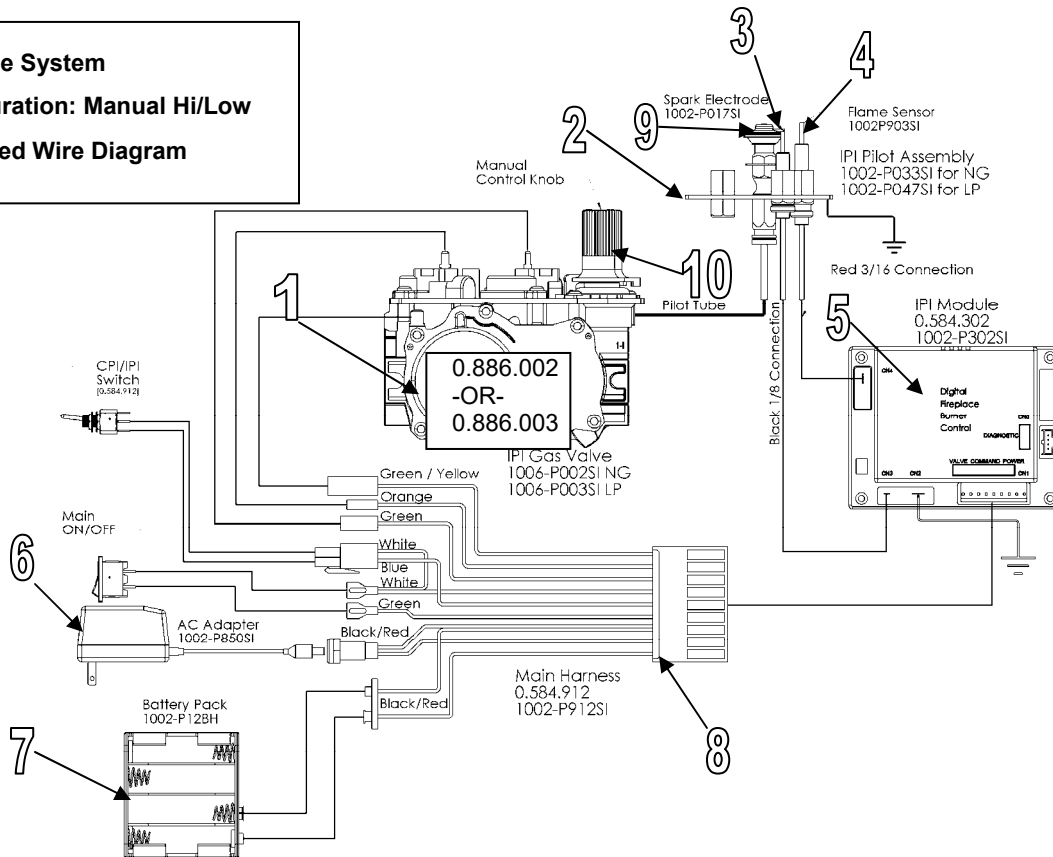

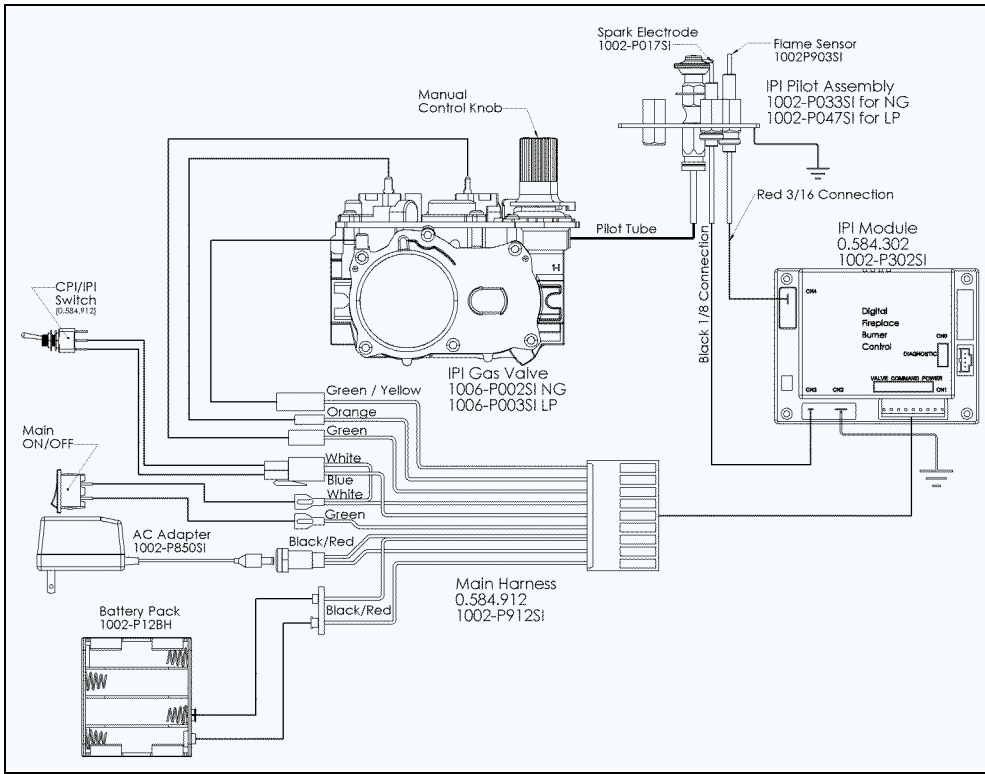

Configuration #1: Basic manual HI/LO and manual ON/OFF capabilities.

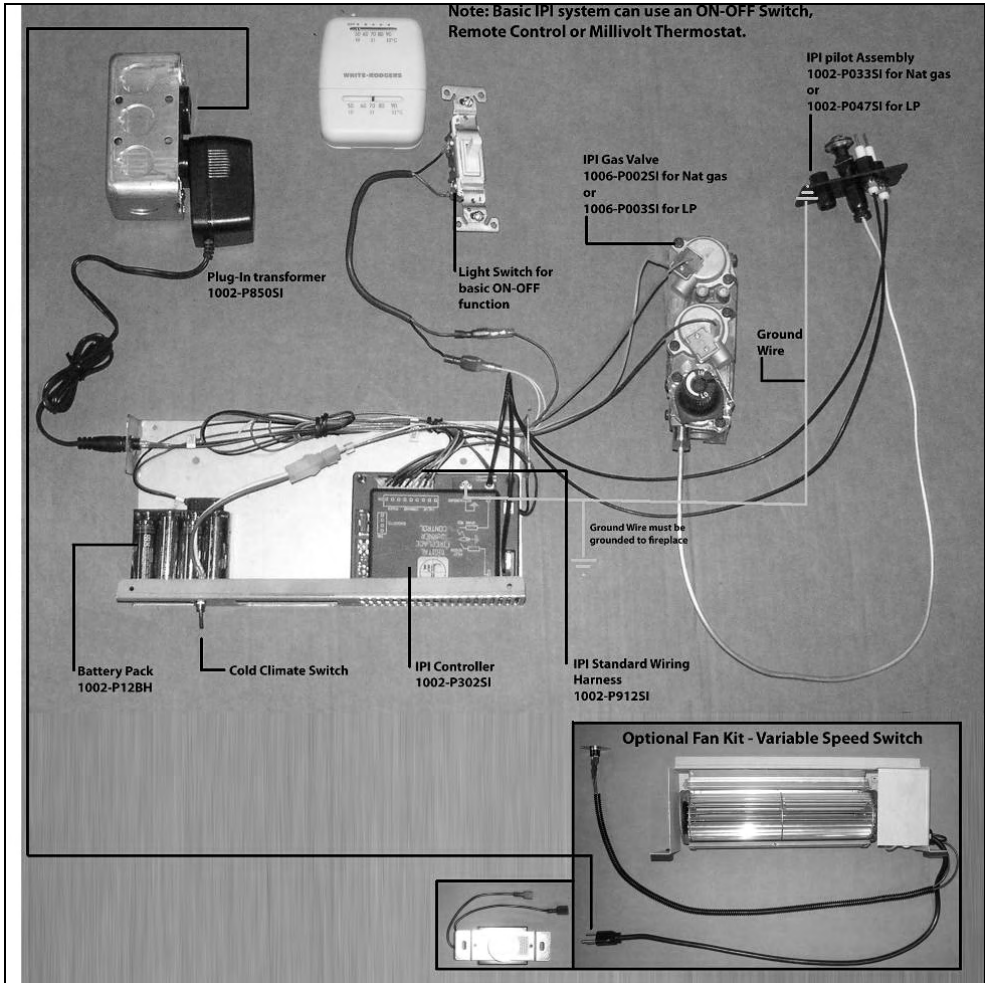

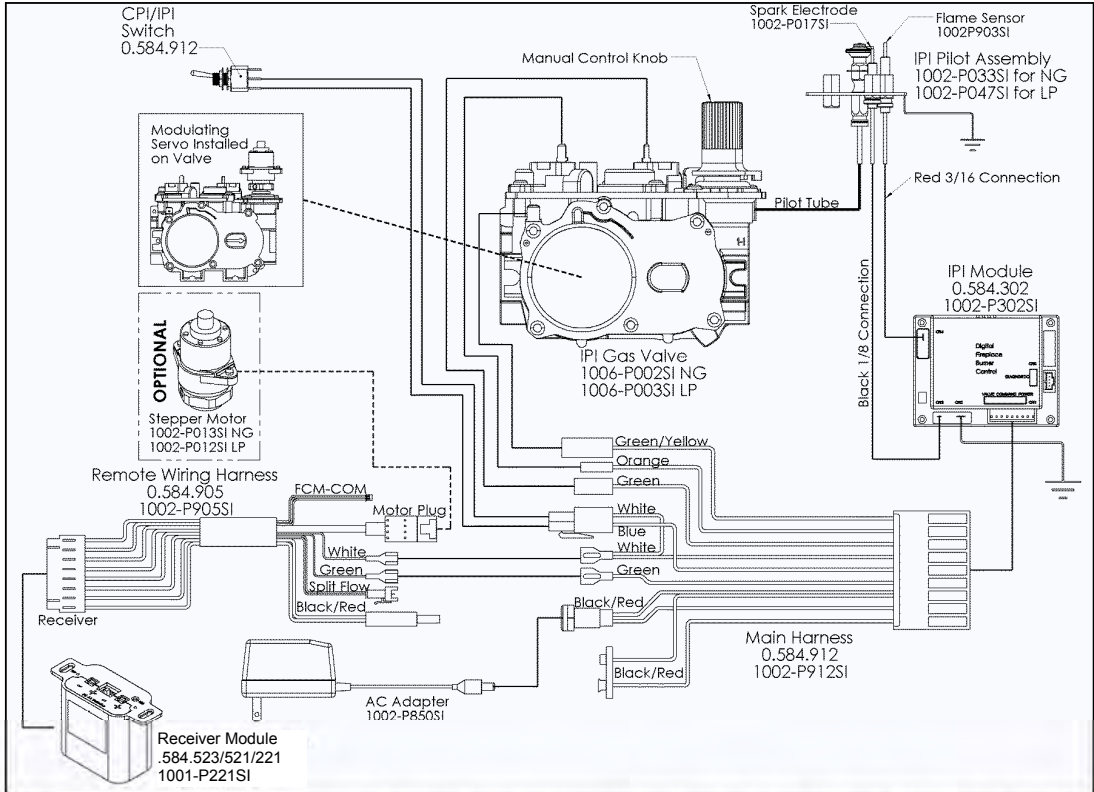

Configuration #2: Remote ON/OFF and manual HI/LO capabilities. OPTIONAL: For units with remote HI/LO capabilities, a modulating servo is required to be installed on the valve. The connectors to this servo must be connected to the Remote Harness as shown in the figure above.

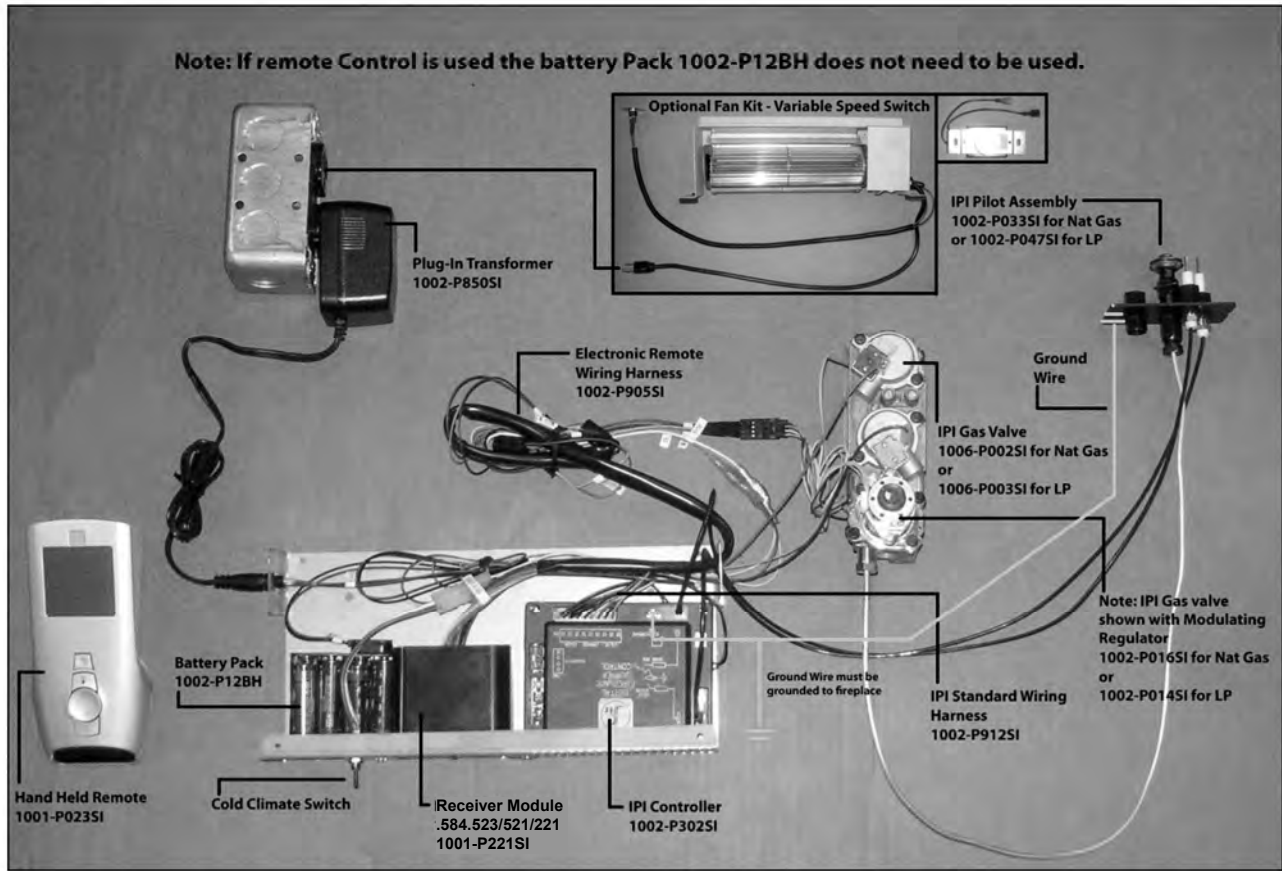

# Operating the Receiver Without Batteries For GT / EGT / GTM / EGTM Remote Controls

-Wiring Harness P/N 1002-P906si required for both IPI & Millivolt systems.

-Millivolt Systems will also require Power Adapter P/N 1002-P850si.

The Remote Receiver & IPI or Millivolt system can be powered by the AC Adapter. This is advantageous if you do not want to use batteries. Simply connect the AC Adapter into the Remote Control Wiring Harness as per the diagrams below.

## IPI System EGTM

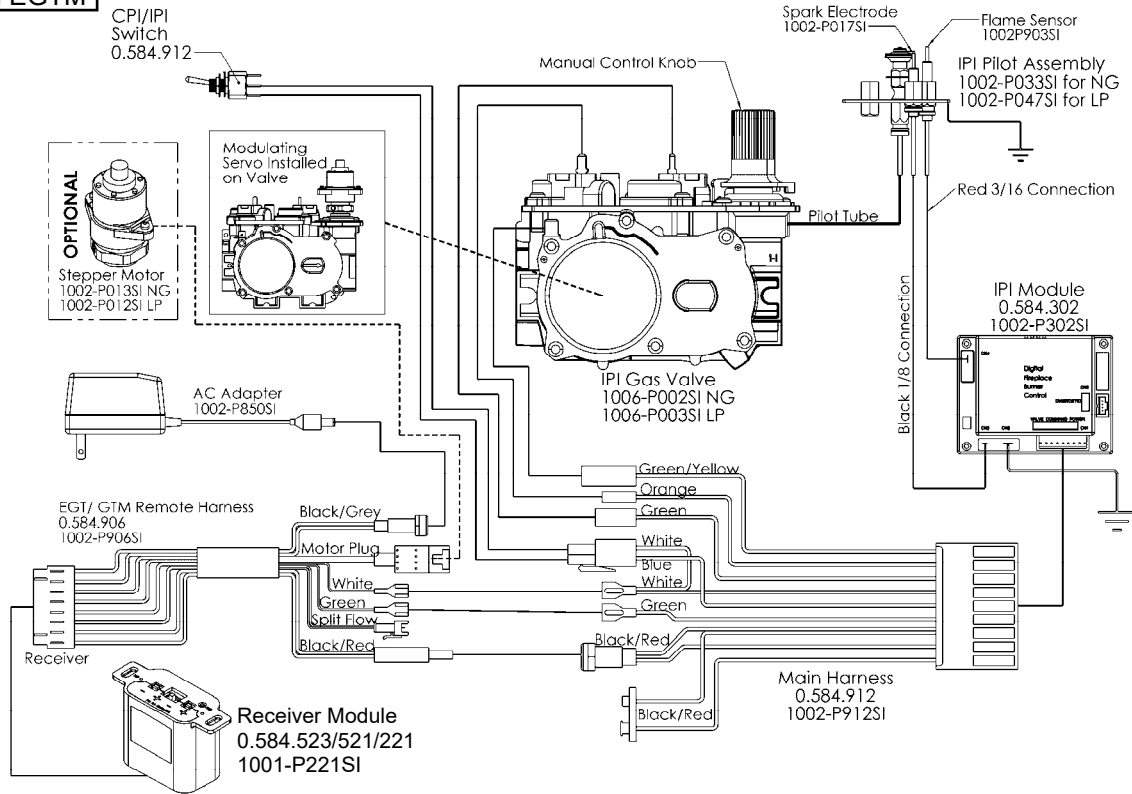

## Millivolt System GTM

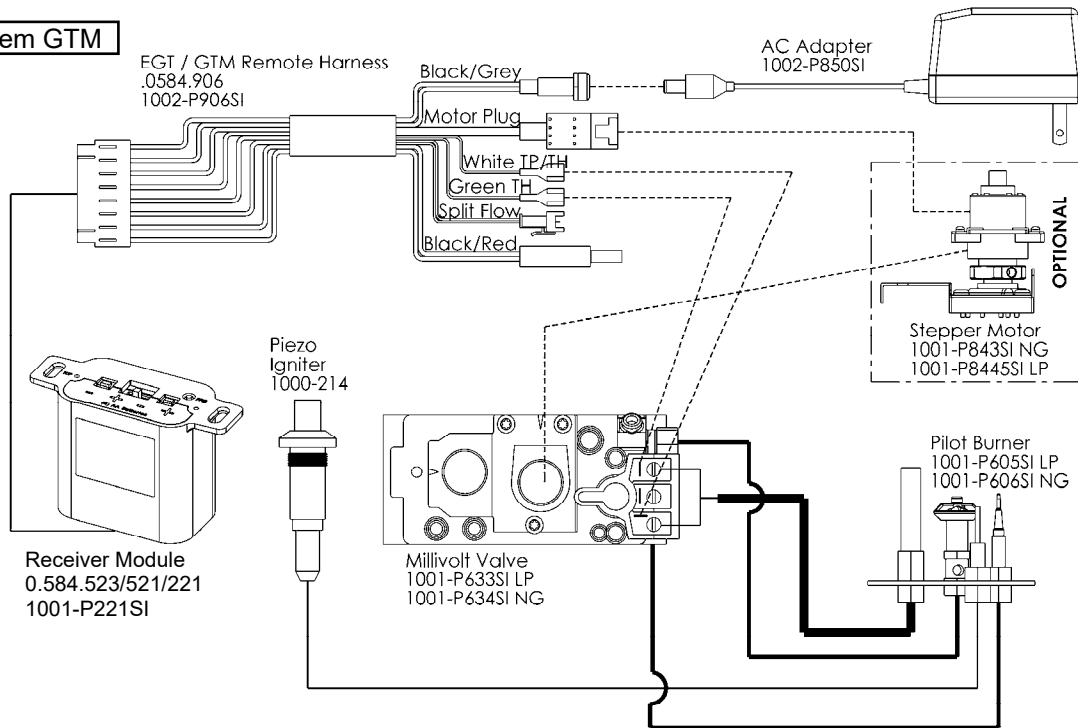

\*In the U.S.A. Thermostats are not permitted for Vented Gas Fireplaces (ANSI Z21.50b-2009 -Decorative).





# Electronic Ignition Lighting Instructions

## **WARNING**

If you do not follow these instructions exactly, a fire or explosion may result causing property damage, personal injury or loss of life.

Always light the pilot whether for the first time or if the gas supply has ran out with the glass door opened or removed.



### FOR YOUR SAFETY READ BEFORE LIGHTING:

- A. This fireplace is equipped with an ignition device which automatically lights the pilot. Do not try to light by hand.
- B. Before operating smell all around the fireplace area for gas and next to the floor because some gas is heavier than air and will settle on the floor.
- C. Do not use this fireplace if any part has been under water. Immediately call a qualified service technician to inspect the fireplace and replace any part of the control system and any gas control which has been under water.

### WHAT TO DO IF YOU SMELL GAS:

- Turn off all gas to the fireplace.
- Open windows.
- Do not try to light any appliance.
- Do not touch any electric switch; do not use any phone in your building.
- Immediately call your gas supplier from a neighbor's phone. Follow the gas supplier's instructions.
- If you cannot reach your gas supplier, call the fire department.

### LIGHTING INSTRUCTIONS

1. Stop! Read the above safety information on this label.
2. Remove batteries from receiver, and/or Battery Backup Pack.
3. Turn off all electric power to the fireplace.
4. This fireplace is equipped with an ignition device which automatically lights the pilot. Do not try to light the pilot by hand.
5. Open the glass door.
6. Turn manual shutoff valve clockwise  to off (Located behind the access panel).
7. Wait five (5) minutes to clear out any gas. If you smell gas including near the floor, **STOP!** Follow "B" in the above safety information on this label. If you don't smell gas go to the next step.
8. Turn manual shutoff valve counter-clockwise  to on.
9. Close the glass door.
10. Turn on all electric power to the fireplace and re-install batteries into the Transmitter/Receiver, and/or Battery Backup Pack.
11. Turn "On" Switch that operates the Main Burner. If using a Remote Control refer to Remote Control Operation Manual for activation.

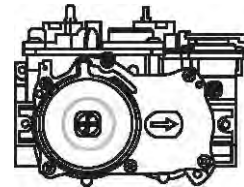

### TO TURN OFF GAS

1. Turn off all electric power to the fireplace if service is to be performed, including removing batteries from Remote Transmitter/Receiver and/or Battery Backup Pack.
2. Access door inside the firebox must be removed to access the manual shutoff valve.
3. If alternate shut-off valve was installed it can be shutoff instead of going through the fireplace to access the fireplace shut off valve.

# Proflame 2- Parts List- Basic System, Parts List, Configuration GTMFL

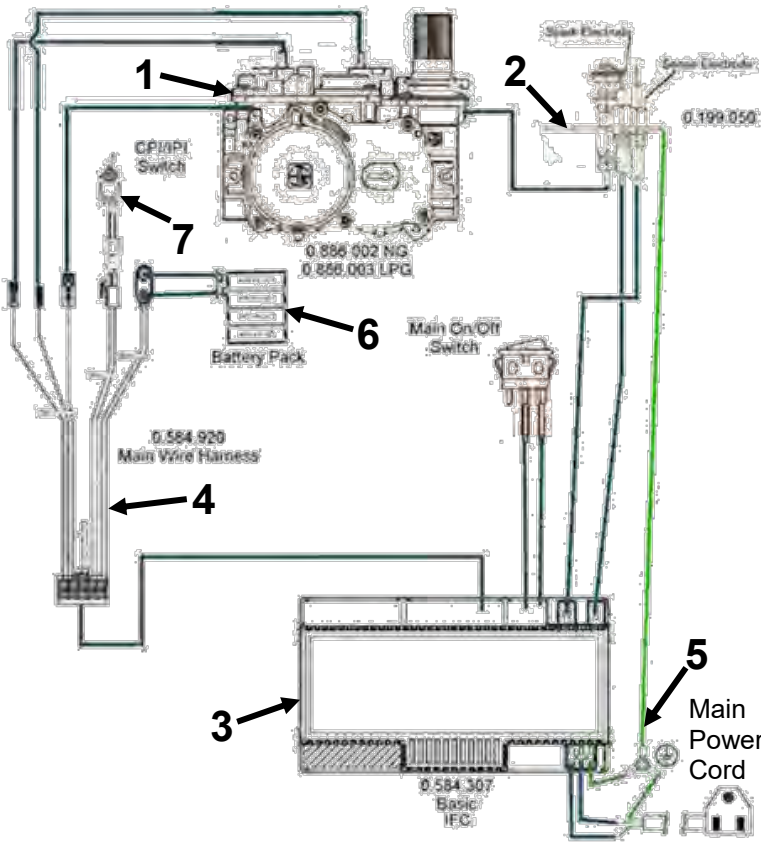

| ITEM NO. | PART NUMBER | DESCRIPTION   |
|----------|-------------|---|
| 1.       | 1005-P001si | IPI Valve NG with Stepper Motor 885.001                               |
|          | 1005-P002si | IPI Valve LP with Stepper Motor 885.001                               |
|          | 1006-P002si | IPI Valve NG Hi / Lo  |
|          | 1006-P003si | IPI Valve LP Hi / Lo  |
| 2.       | 1002-P033si | Pilot NG IPI 199.059  |
| 3.       | 1005-P325si | Module IPI PF2 584.325  |
|          | 1006-P307si | Integrated Fireplace Control (Basic) 0.584.307                        |
| 4.       | 1006-P920si | Wire harness (Valve, APS connection Jumped, CPI connection) 0.584.920 |
| 5.       | 584-PWR-C   | Wire Harness PF2 Main Power Cord                                      |
| 6.       | 1002-P12BH  | Battery Housing   |
| 7.       | 1006-P921si | Wire harness for Split flow 0.584.921 (Not available)                 |
| 8.       | 1005-P2SCH  | Label – PF2 Schematic Decal   |
| 9.       | 584-X12     | Power Vent Harness  |
| 10.      | 584-X4P     | Connector- ON/OFF Jumper PF2 651-1766990                              |
| 11.      | 584-ACC01-C | Wire Harness PF2  |
| 12.      | 584-X10     | Wire Harness PF2 - Accessories  |
| 13.      | 1005-P924si | Harness PF2 IPI 584.924   |
| 14.      | 1005-P042si | Transmitter PF2 584.042   |
| 15.      | 1001-P591si | Battery AAA 658-LR03XWA Transmitter                                   |

Proflame 2 System Configuration:

**GTMFL SHIPS WITH REMOTE CONTROL TRANSMITTER**



Proflame Transmitter 0.584.0XX

**NOTE:** Fan and / or Light Options are not available on some models of fireplace. **Check with your dealer.**

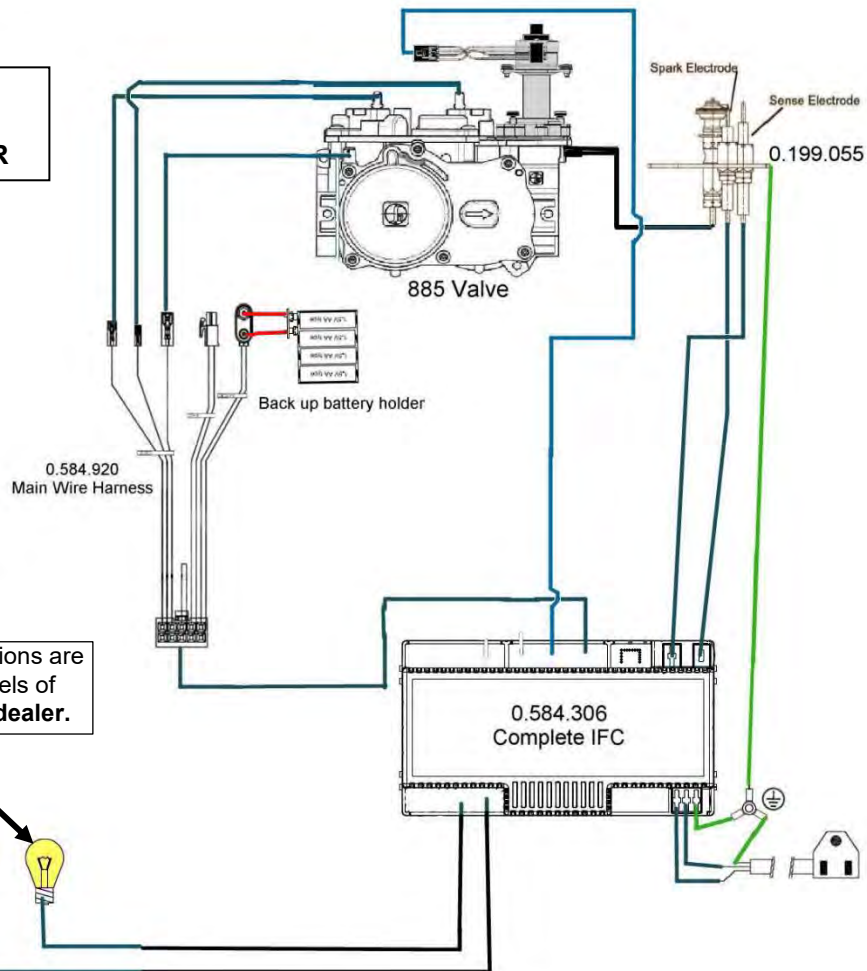

# Proflame 2 Remote Control

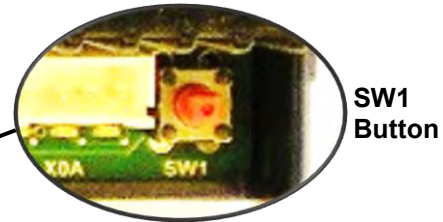
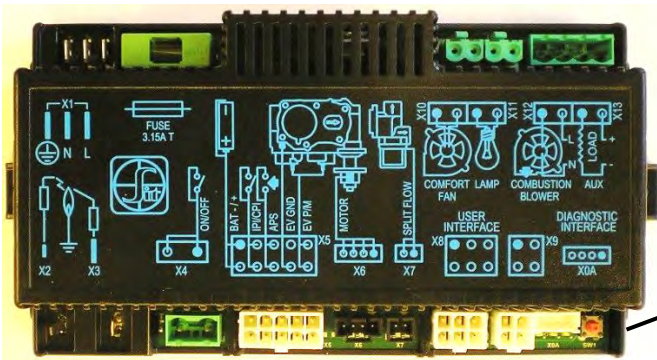

## Pairing Remote Control:

- Install the 3 AAA type batteries in the battery bay, located on the base of the Remote Control. Note polarity of the batteries and insert them as indicated.
- Connect the AC power supply to the IFC.
- Press the SW1 button on the IFC module so the IFC will “beep” and a red LED is illuminated to indicate that the IFC is ready to synchronize with a Remote Control within 10 seconds. With the batteries already installed in the Remote Control, push the ON button. The receiver will “beep” four times to indicate the Remote Control’s command is accepted.

The system is now initialized.

## Resetting Proflame II Module for Manual Use

Should the transmitter get misplaced, broken or not wanted the PF2 Module can be reset to a manual system. A manual on/off switch or thermostat may be installed at the X4 connector (this connection is Jumped at the factory) no power is required.

The following sequence must be followed to reset the PF2 Module:

- Press the Red **SW1** button until you hear three beeps.

- Within 10 seconds press the **SW1** button again until you hear it beep.
- The PF2 module may now be turned on/off manually (x4 connector) by a switch (not supplied), the pilot will remain on CPI (continuous pilot ignition) mode, all other functions of main burner, fan and lights will be on the high setting.

## Fan Startup and Shutdown Timings:

Fan setting is started with a delay of 5 minutes from the fireplace ignition and stopped with a delay of 12 minutes from the fireplace switching off.

## Low battery power detection

When the Remote Control’s batteries are low, a Battery Icon will appear on the LCD display before all power is lost. When the batteries are replaced this icon will disappear.

## Battery backup

The PF2 module is powered by line voltage (AC) with provision of battery backup in case of main power loss. Fans and lighting features will not function with the PF2 module is powered by battery backup. It is recommended that the 4 x AA batteries are changed before each heating season.



# IPI Proflame 2 System Configuration: Modulating Controls Simplified Wiring Diagram

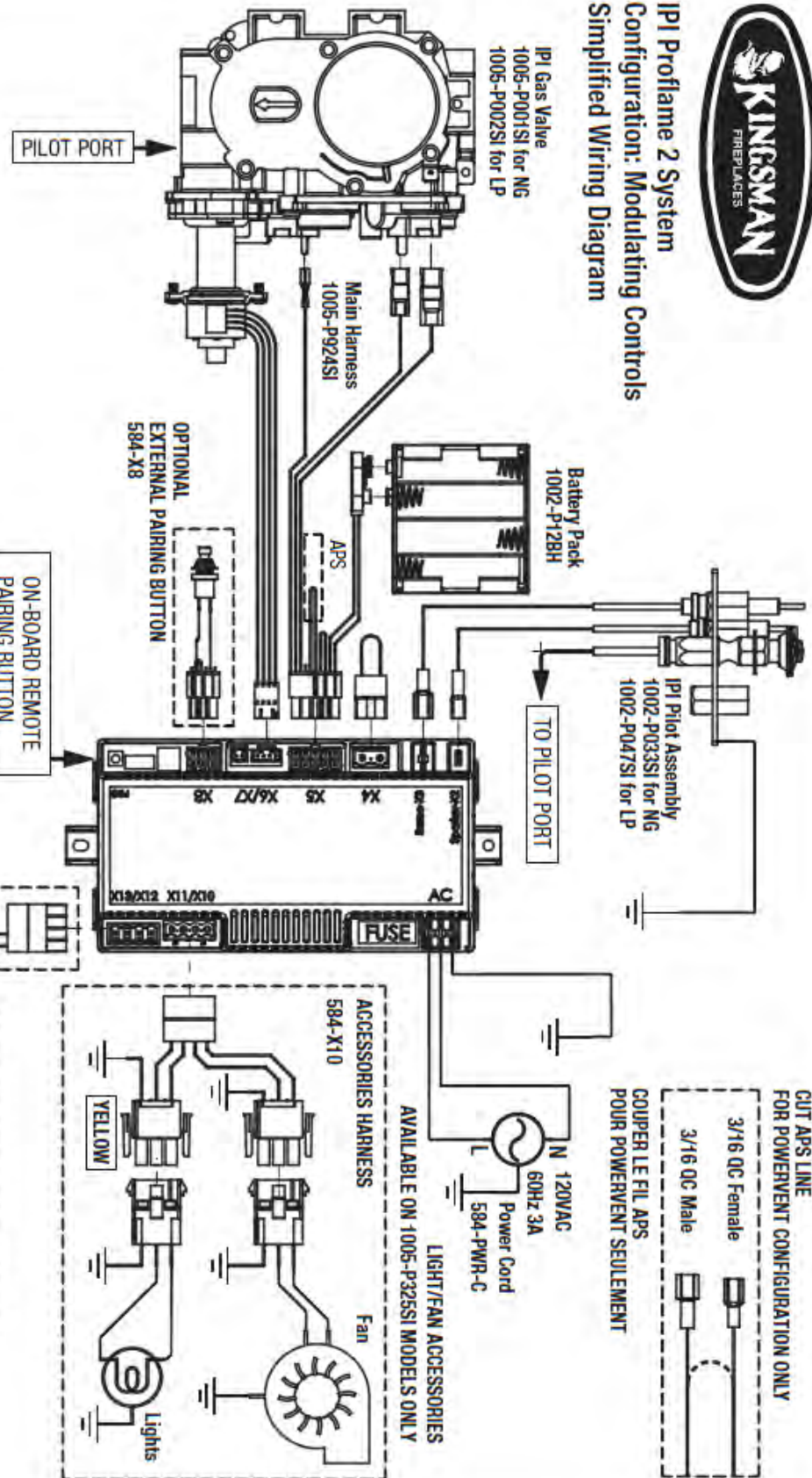

Manufactured by: Kingsman Fireplaces  
2340 Logan Avenue  
Winnipeg, MB R2R 2V3

For use with all Kingsman manufactured IPI Proflame 2 models, for all types of gas noted on rating plate. Supply 120VAC 60Hz 3A, 6 volts battery backup.

Pour utilisation avec tous les modèles IPI Proflame 2 fabriqués par Kingsman, pour tous les types de gaz noté sur la plaque signalétique. Voltage d'alimentation: 120VAC 60Hz 3A et 6 volts pour le bloc-piles de secours.

This component should be installed by a qualified service agency.  
Ce composante doit être installée par une entreprise de service qualifiée.

Part #1005-P2SC4

# Vent Termination

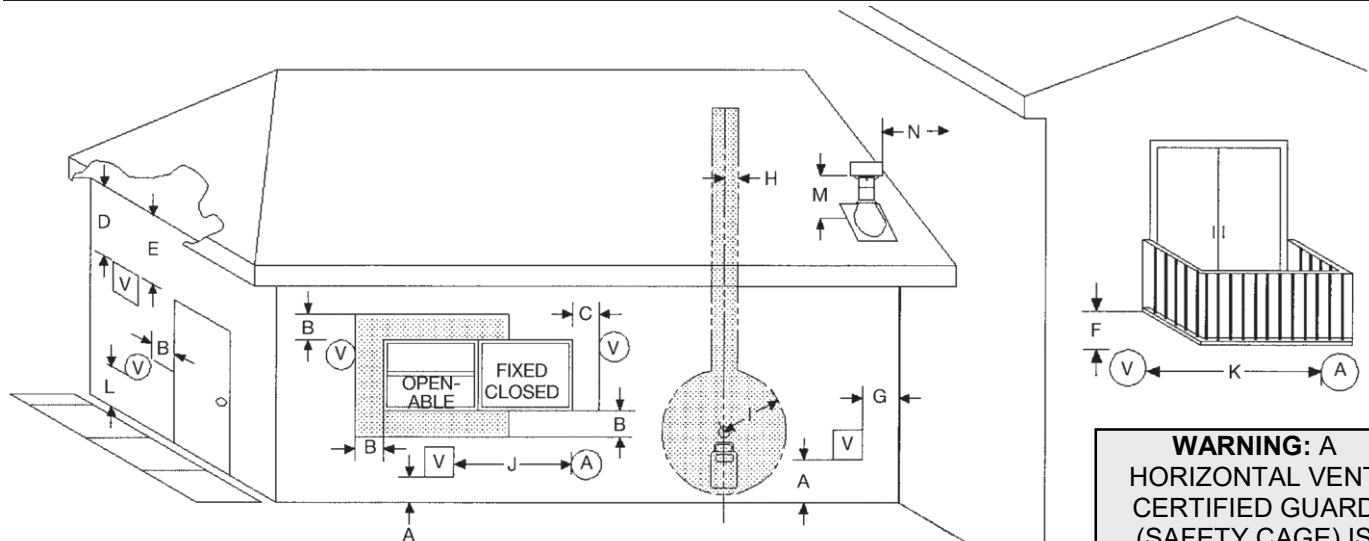

**WARNING: A HORIZONTAL VENT CERTIFIED GUARD (SAFETY CAGE) IS AVAILABLE WHEN REQUIRED BY LOCAL CODES.**

- Area Where Terminal Not Permitted.
- Air Supply
- Measure to edge of the Termination Plate
- Measure to edge of the Round Termination

**Notes:**  
 1) Clearances are to the edge of the terminal plate. Add 6-3/4" to clearances to arrive at centerline.  
 2) Local codes or regulations may require different clearances.

- A. Clearance above grade, veranda, porch, deck, or balcony 12 inches (30cm) minimum.1
- B. Clearance to window or door that may be opened. 12 inches (30cm) minimum for appliances 100 000 Btuh (30 kW) and lower, in Canada. 9 inches<sub>2</sub> (23cm) for appliances 50 000 Btuh and lower, in USA.
- C. Clearance to permanently closed window minimum 12 inches (30cm) recommended to prevent condensation on window, in Canada. 9 inches<sub>2</sub> (23cm) for appliances 50 000 Btuh and lower, in USA.
- D. Vertical clearance to ventilated soffit located above the termination within a horizontal distance of 2 feet (60cm) from the center line of the termination. 18 inches (46cm) minimum.<sub>5</sub>
- E. Clearance to unventilated soffit 12 inches (30cm) minimum.
- F. Clearance under veranda, porch, deck or balcony 12 inches<sub>4</sub> (30cm) minimum.<sub>4</sub> US<sub>5</sub>
- G. Clearance from a perpendicular inside wall or outer corner to the edge of the vent terminal plate is 3" (minimum).
- H. Clearance to each side of center line extended above meter/regulator assembly 3 feet (91cm) within a height 15 feet (4.5m) above the meter/regulator assembly.
- I. Clearance to service regulator vent outlet 3 feet (91cm) minimum.<sub>1</sub> US<sub>5</sub>
- J. Clearance to non-mechanical air supply inlet to building or the combustion air inlet to any other appliance: In Canada, 6 inches (15cm) for appliances ≤10,000 Btuh (3kW), 12 inches<sub>1</sub> (30cm) minimum for appliances >10,000 Btuh (3kW) and ≤100,000 Btuh (30kW), 36 inches (91cm) for appliances >100,000 Btuh (30kW). In the USA, 6 inches<sub>2</sub> (15cm) for appliances ≤10,000 Btuh (3kW), 9 inches (23cm) for appliances >10,000 Btuh (3kW) and ≤50,000 Btuh (15kW), 12 inches (30cm) for appliances >50,000 Btuh (15kW).
- K. Clearance to a mechanical air supply inlet 6 feet (1.8m) minimum (1), in Canada. In USA, 3 feet (91cm) above if within 10 feet (3m) horizontally(2).
- L. Clearance above paved sidewalk or a paved driveway located on public property 7 feet (2.1m) minimum.<sub>3</sub>

- M. Clearance above highest point of exit on roof 18 inches (45cm).
- N. Clearance to perpendicular wall 24 inches (60 cm). (Recommended to prevent re-circulation of exhaust products. For additional requirements check local codes.)
- O. A moisture-exhaust duct shall not terminate within 3 ft (1 m) in any direction of a service regulator or fresh-air intake.

**NOTE:** Clearances are to the edge of terminal plate, add 6-3/4" to clearances to arrive at center line.  
**NOTE:** Local Codes or Regulations may require different clearances.

**Termination**

It is imperative that the vent termination be located observing the minimum clearances as shown. There must not be any obstruction such as bushes, garden sheds, fences, decks or utility buildings within 24" from the front of the termination plate. Do not locate termination where excessive snow or ice build-up may occur. Be sure to check vent termination area after snow falls and clear to prevent accidental blockage of venting system. When using snow blowers, make sure snow is not directed towards vent termination area. Venting terminal shall not be recessed into a wall or siding. If finishing the outside wall with vinyl or wood siding it is recommended that a Siding Shield be installed, Part Number ZDVSSLR.

1. In accordance with the current CSA B149.1, Natural Gas and Propane Code.
2. In accordance with the current ANSI Z223.1/NFPA 54, National Fuel Gas Code.
3. A vent shall not terminate where it may cause hazardous frost or ice accumulations on adjacent property surfaces.
4. Permitted only if veranda, porch, deck, or balcony is fully open on a minimum of two sides beneath the floor.
5. Clearance in accordance with local installation codes and the requirements of the gas supplier.

## FDV451 / MQFDV453 General Venting Information

This gas appliance is approved to be vented either through the side wall or vertically through the roof. **Only Kingsman Flex (Z-Flex) Venting Kits and components specifically approved and LABELED for this stove may be used.** This appliance is also approved for use Simpson-Duravent Direct Vent system (Model DV-GS Series), BDM Pro Form Direct Vent, Ameri-Vent Direct Vent Pipe System, ICC Excel Direct, Metal Fab Sure-Seal DV and Selkirk Direct Temp.

### Rigid or Hard Pipe

When using Simpson Duravent, Ameri-Vent pipe, BDM Pro Form Direct Vent, ICC Excel Direct, Metal Fab Sure-Seal DV and or Selkirk Direct Temp a Duravent hard pipe adapter must be used (part # ZDVDF A for fire- places and part # ZDV DKA for Stoves, Serenity and ZDV3624B). Follow installation instructions provided by Simpson Duravent/Ameri-Vent/Selkirk Direct Temp, ICC Excel Direct, and Metal Fab Sure-Seal DV for installation of pipe and adhere to the clearance to combustibles provided in this manual. Apply a bead of Mill Pac high temp sealant to all joints of pipes, adapters and termination, when using Kingsman Flex (Z-Flex) venting and Simpson Duravent venting.

### Flex Pipe Venting

Kingsman Flex pipe is shipped in unexpanded length. When installing pipe expand the lengths. Pipe can be expanded to twice their lengths e.g. 4ft. to 8ft. Fully expand pipe and cut off excess.

Do not use more than 2 couplers to extend short pipes. Single sections are preferred in an installation attaching at the fireplace and termination.

Place the spring spaces provided approximately every two feet to stabilize 4" flex in the center of 7" flex. When forming bends place spring in bend or before and after. (See Fig. 1). Horizontal runs require support metal straps every 2 feet. In offset installation support straps should be used to stabilize pipe.

Expand 4" and 7" flex pipe to the point that the 7" protrudes approximately 2 to 3 inches past outer wall and the 4" flex protrudes approximately 2 to 3 inches past the 7" flex. (See Fig. 1). Attach the 4" pipe to the termination first and secure with sealant and screws then attach the 7" flex to the termination with caulking and screws. Termination may then be moved back to the outer wall and attached to home screwing into the framing. Silicone around termination to waterproof. If siding shield is going to be used attach this using same attaching hole as the top of termination after termination has been caulked for water proofing.

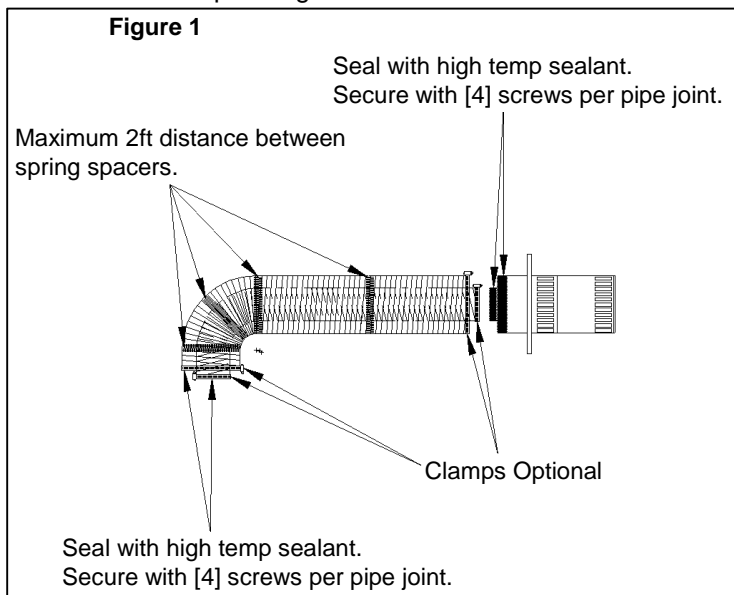

**NOTE:** It is critical to the proper and safe operation of this fireplace that on all connections the inner liner and the outer casing are both caulked with liberal amounts of sealant. Do not use any kind of tape or silicone other than that recommended in this manual, Mill Pac Sealant.

### **Use Hi Temp Sealant**

Apply a bead of Mill Pac high temp sealant to all joints and use four screws to secure each pipe at fireplace, termination and any joint if joining any sections of pipe.

**⚠ WARNING:** DO NOT mix parts from different systems unless stated in the manual.

**REMEMBER THAT A 1/4" VERTICAL RISE IS REQUIRED FOR EVERY 12" OF HORIZONTAL RUN.**

## FDV451 / MQFDV453 Venting Routes and Components

Since it is very important that the vent system maintain its balance between the combustion air intake and the flue gas exhaust, certain limitations as to vent configurations apply and must be adhered to.

See venting chart for total horizontal and vertical runs

For every 90° elbow after the first 90° elbow the horizontal run must be reduced by 36".

For every 45° elbow after the first 90° elbow the horizontal run must be reduced by 18".

This does not apply if the 45° elbows are installed on the vertical part of the vent system. 45° elbows can be installed in either the horizontal or vertical runs.

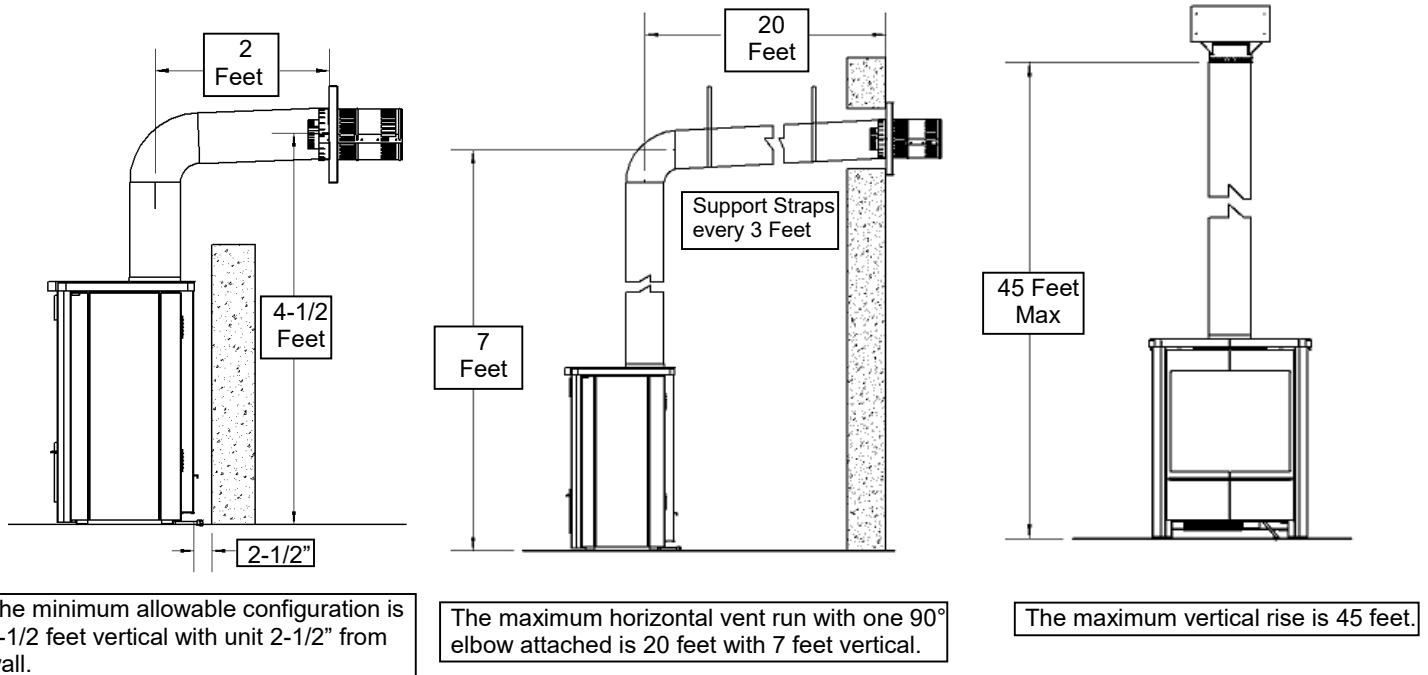

**Minimum clearances on venting (2" to top of elbow), (1" from top of horizontal pipes), (1" on all other existing pipes).**

Only trim kit(s) supplied by the manufacturer shall be used in the installation of this appliance. Draft Relief Openings must not be covered or blocked.

**IMPORTANT:** Always locate the fireplace in such a way that a minimum of offsets and/or horizontal runs are required. 1/4" vertical rise is required for every 12" horizontal run.



**IMPORTANT: ALWAYS LOCATE THE STOVE IN SUCH A WAY AS TO MINIMIZE THE NUMBER OF OFFSETS AND/OR HORIZONTAL RUNS. A 1/4" VERTICAL RISE IS REQUIRED FOR EVERY 12" OF HORIZONTAL RUN.**

The following table shows the relationship between vertical and horizontal vent lengths and will help you to determine the correct vent lengths for optimum stove performance.

**HOW TO USE THE VENT TABLE**

1. Determine the height of the system and the number of elbows required.
2. Use the Venting Chart to determine the maximum horizontal distance allowed.

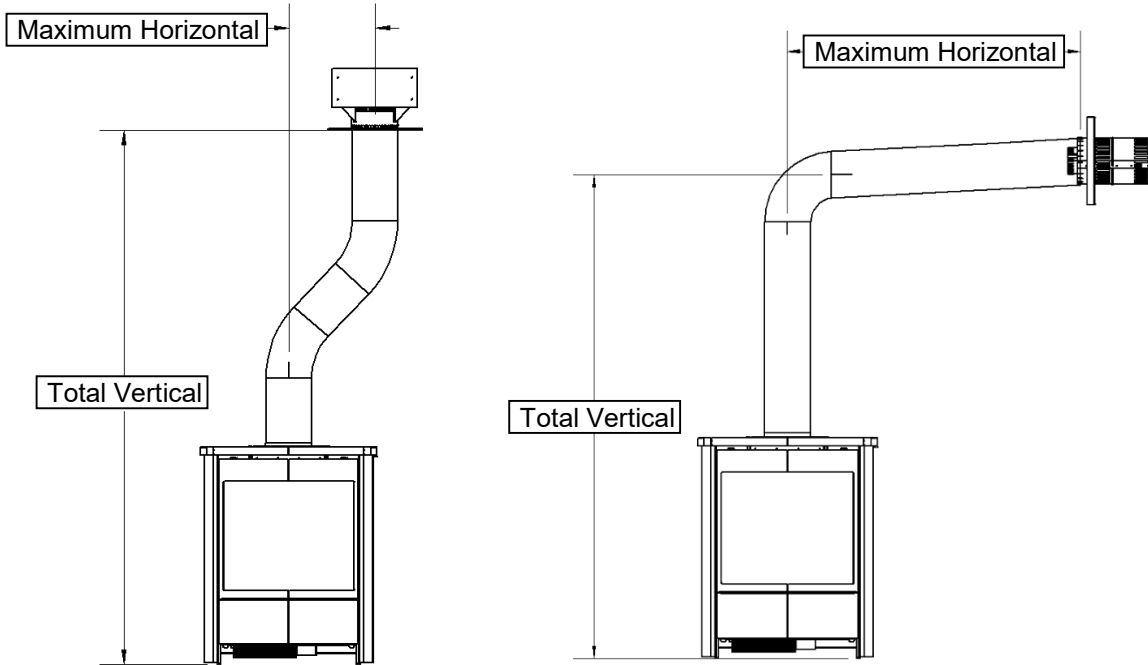

| Total Vertical |        | Max. Total Horizontal |        |
|----------------|--------|-----------------------|--------|
| Feet           | Meters | Feet                  | Meters |
| 4-1/2          | 1.4    | 2                     | .6     |
| 5              | 1.5    | 5                     | 1.5    |
| 6              | 1.8    | 10                    | 3      |
| 7              | 2.1    | 20                    | 6.1    |
| 8              | 2.4    | 20                    | 6.1    |
| 9              | 2.7    | 20                    | 6.1    |
| 10             | 3.0    | 20                    | 6.1    |
| 11             | 3.4    | 20                    | 6.1    |
| 12             | 3.7    | 20                    | 6.1    |
| 13             | 4.0    | 20                    | 6.1    |
| 14             | 4.3    | 20                    | 6.1    |
| 15             | 4.6    | 20                    | 6.1    |
| 16             | 4.9    | 20                    | 6.1    |
| 17             | 5.2    | 20                    | 6.1    |
| 18             | 5.5    | 20                    | 6.1    |
| 19             | 5.8    | 20                    | 6.1    |
| 20             | 6.1    | 20                    | 6.1    |
| 25             | 7.5    | 20                    | 6.1    |
| 30             | 9.0    | 15                    | 4.6    |
| 40             | 12     | 10                    | 3      |
| 45             | 14     | 0                     | 0      |

Note: For each 45° elbow installed in the horizontal run, the length of the horizontal run must be reduced by 18" (45 cm). This does not apply if the 45° elbows are installed on the vertical part of the vent system.

Note: For every 90° elbow after the first 90° elbow the horizontal run must be reduced by 36" (90cm).

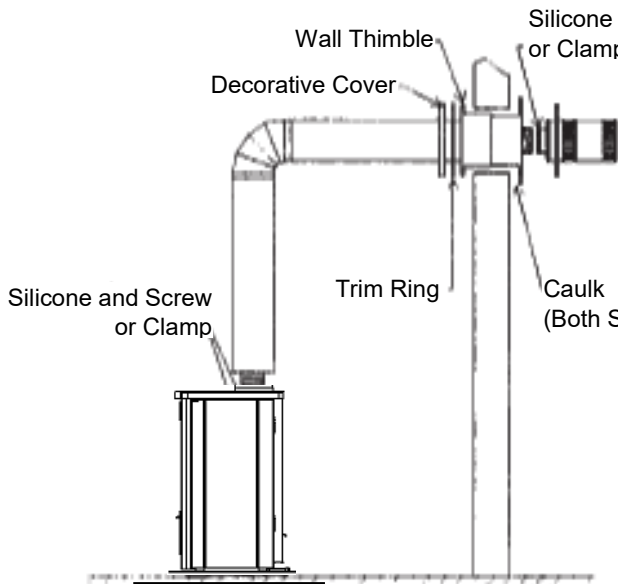

FIGURE 1

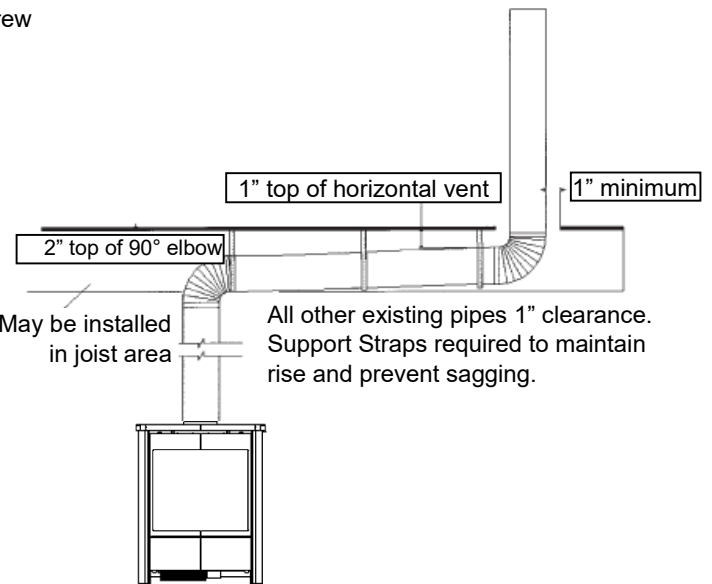

FIGURE 2

1. Use the Venting Table to determine the minimum distance from the bottom of fireplace to center of vent. Cut a hole through the wall allowing for an 11" x 11" (inside diameter) in combustible walls for wall thimble or an 8" diameter hole in a non-combustible wall (See Figure 3).
2. For the clearance to combustibles above a 90 degree bend see **Clearance to Combustibles** section.
3. Select the approximate vent length, precise measurements are not needed as your flex pipe can be expanded to twice its shipped length for ease of installation
4. To install wall thimble center over 11" x 11" (inch) framing from both sides of wall and secure. Route flex vent pipe through wall thimble.
5. Before joining pipes, apply a bead of high temperature sealant (Mill Pac) to end of pipe. First attach the four inch (4") flue pipe to the vent termination with sealant, and secure with the four screws provided. At this time make sure the spacer springs are attached to the (4") flex pipe as required. Then attach the seven inch (7") pipe by the same method.
6. Mount vent termination and seal to wall using caulking around the wall thimble to weather proof. After installing the vent termination, double check to make sure the pipe extends properly through wall thimble and into vent termination.
7. Before joining pipes to fireplace flue, apply a bead of high temperature sealant (Mill Pac) to end of pipe. First attach the four inch (4") flue pipe to fireplace with sealant, and secure with the four screws provided. At this time verify that the spacer springs are attached properly to the (4") flex pipe as required. Then attach the seven inch (7") pipe by the same method.
8. Support horizontal pipes every two (2) feet (61 cm) with metal strap bands. Re-check fireplace to make sure it is levelled and properly positioned and secured.
9. Support vertical pipes to maintain a minimum of 1" or greater clearance to combustibles with metal strapping bands.

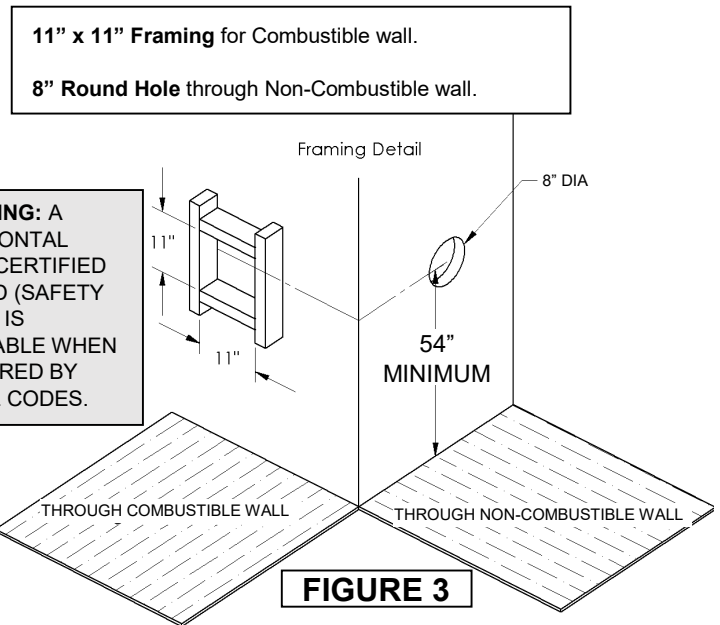

FIGURE 3

If finishing the outside wall with vinyl or wood siding it is recommended that a Siding Shield be installed, Part Number ZDVSSLR.

Two snorkel terminations are available if a vertical rise is necessary on the exterior side of a building:

**Z47ST24** (24" Tall, 14-1/2" Center to Center)      **Z47ST36** (36" Tall, 26-1/2" Center to Center)

Follow standard horizontal venting installation procedures. If the Snorkel Termination is to be located below grade, a window well is recommended with adequate and proper drainage as per local codes. Leave 2" clearance below snorkel to prevent water from entering the Snorkel Termination. Do not enclose the Snorkel within a wall or other type of enclosure and **do not back fill**. Ensure that grade level slopes away from the building. Follow all local codes.

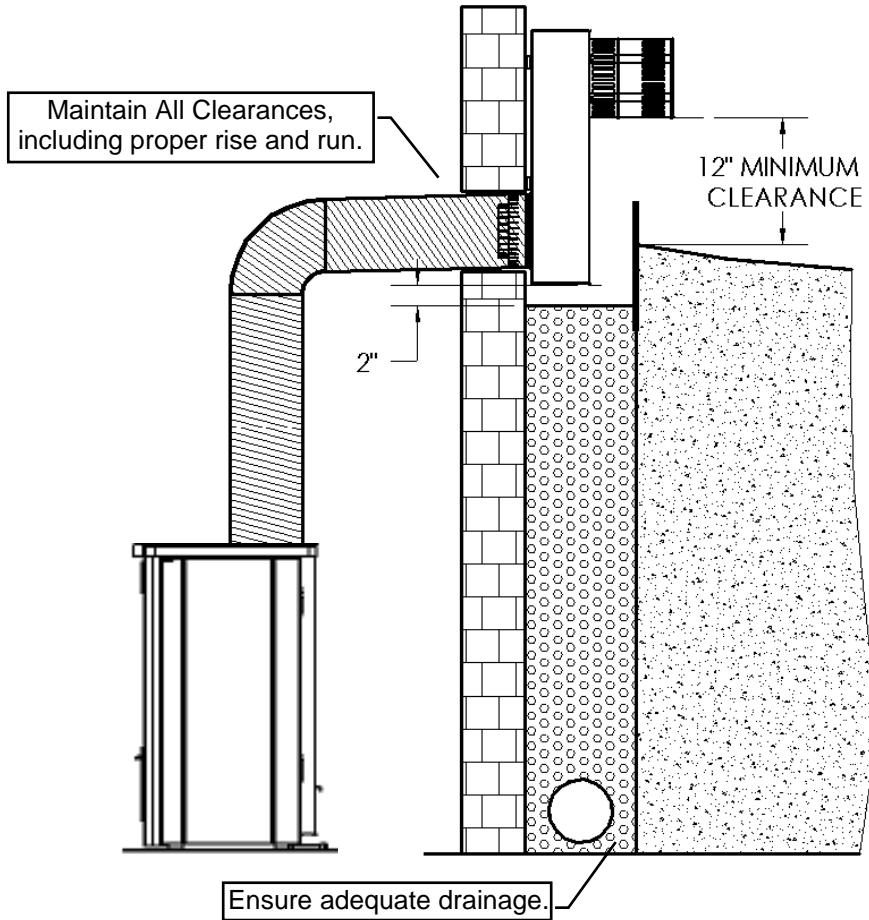

**-FOLLOW ALL LOCAL CODES-**

- A safety cage (Z57STSC) is also available. Place safety cage over snorkel and mount with [4] DT screws (supplied with safety cage).

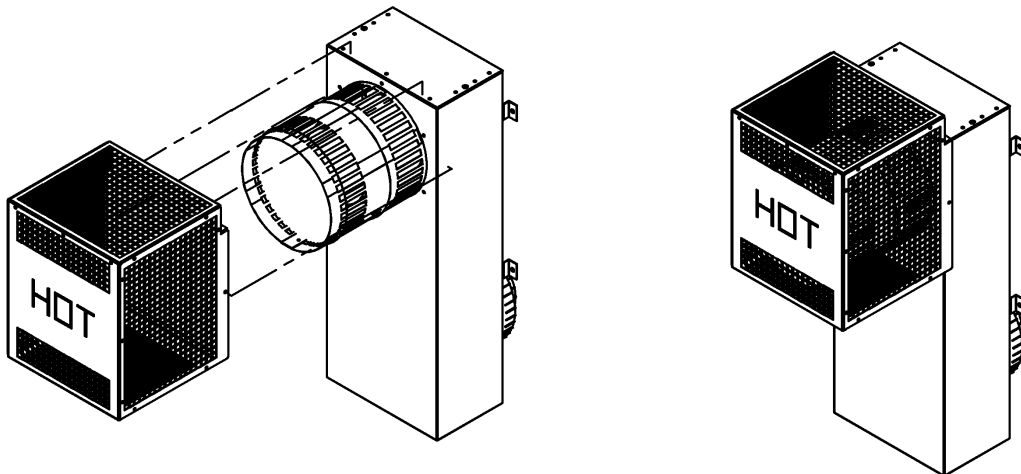

## Vertical Venting above 12 Feet

### FDV451 MQFDV453 Air Restrictor

When vertical venting will be 12 feet or higher, use the Air Restrictor provided.

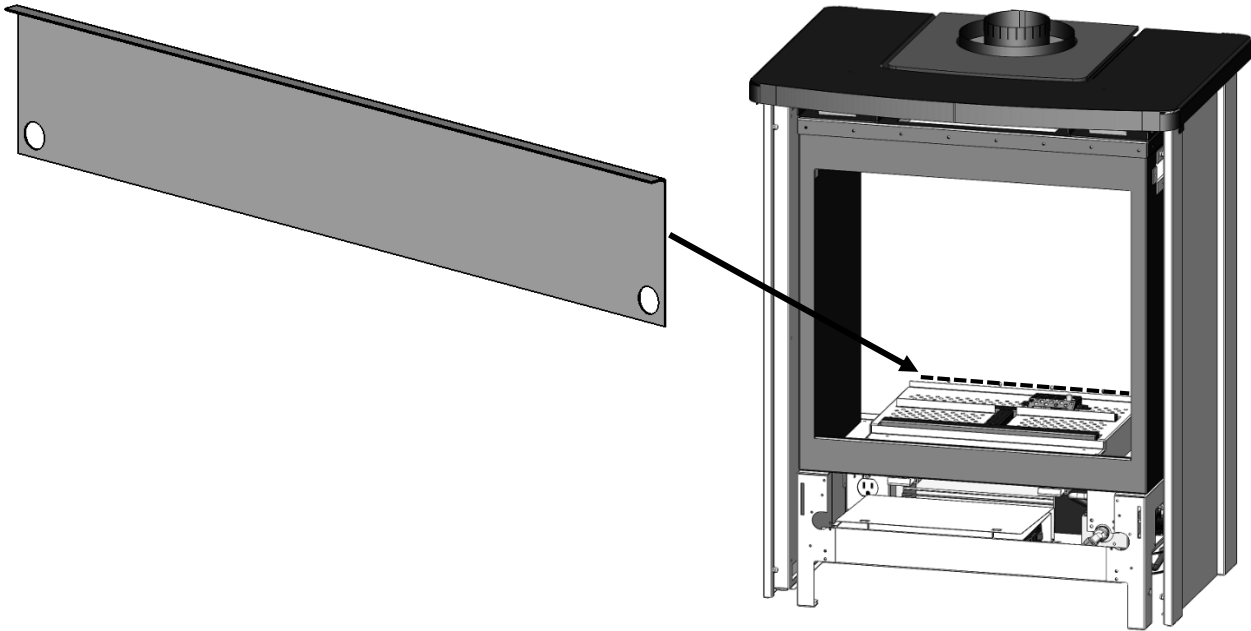

To use Air Restrictor, simply insert behind False Bottom as shown.

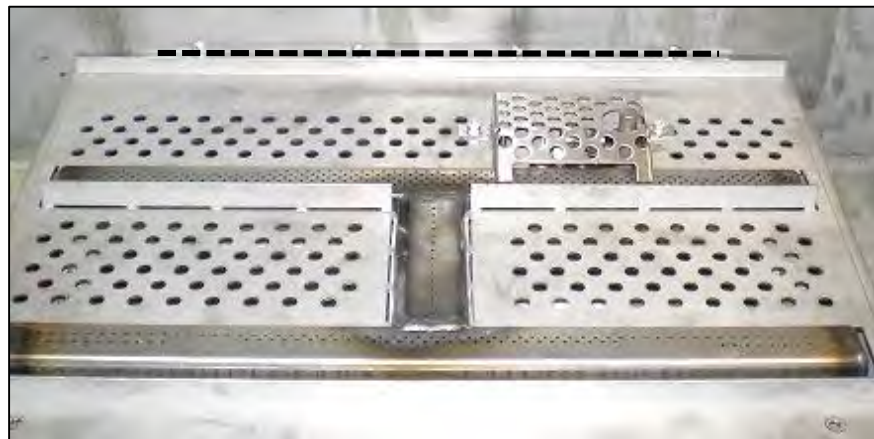

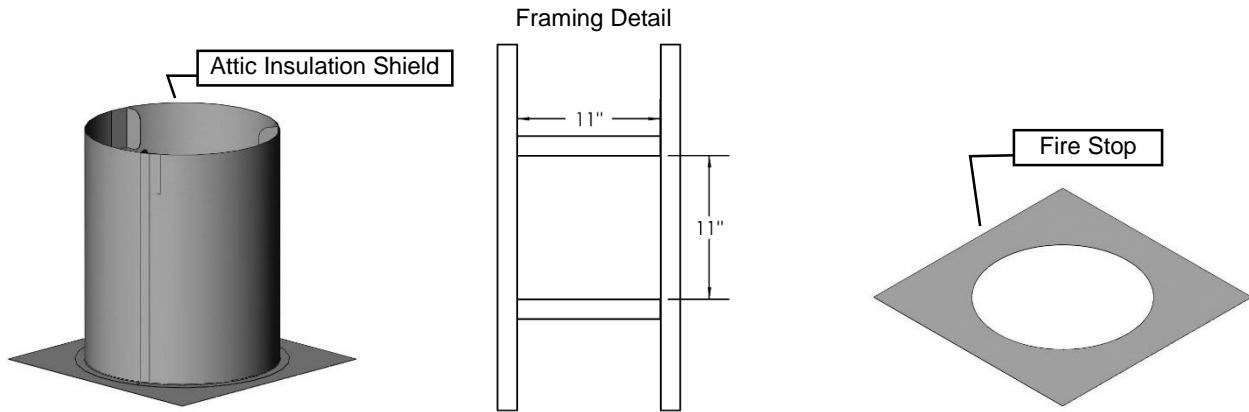

**Using Flex Bends**

Use roof support and rigid pipe at roof level. Flex pipe is not permitted within roof support. When penetrating the roof a rigid galvanized pipe must be used. Attach flex pipe to the rigid pipe with high temperature sealant, secure with four screws assuring the flex pipe and rigid pipe are secured. Attach rigid pipe to termination with sealant and screw with 4 sheet metal screws. The Inner flex pipe must be secured with 4 screws which must penetrate both the flex pipe and inner section of termination. Attach 7" rigid pipe to 7" termination with sealant and screw with 4 sheet metal screws.

Vertical termination clearance is 18" [45.7cm] above the roof, measured from highest point of exit on the roof line. Support vertical pipes to maintain minimum of one inch or greater clearances to combustibles.

**Roof Flashing**

Ensure that you have the proper roof flashing by checking your roof pitch using a level and two rulers, or by using a roof pitch card.

Slide a Roof Flashing suitable to your roof slope over the vent. Place the edge of the flashing plate that will be on the higher part of the roof slope under the shingles. Both the sides and the lower edge lay on top of the shingles.

**NOTE: At the top edge of the flashing plate, lift the shingles and nail the plate to the roof deck, then cement the shingles to the plate with a suitable waterproof mastic.**

Ensure that the chimney is plumb. Square up the flashing plate and nail in place to the roof deck. Use 12 nails with neoprene washers or cover the heads with a suitable waterproof mastic. Wrap the storm collar around the vent above the flashing. Secure the ends together loosely with nut and bolt supplied. Slide the collar down the vent until it comes in contact with the flashing. Tighten the bolt and seal the Storm Collar to the vent with a suitable waterproof non-combustible mastic.

The flashing and storm collar should be painted to match the roof shingles. This will extend its life and improve the appearance. Clean, prime and paint with suitable painting products.

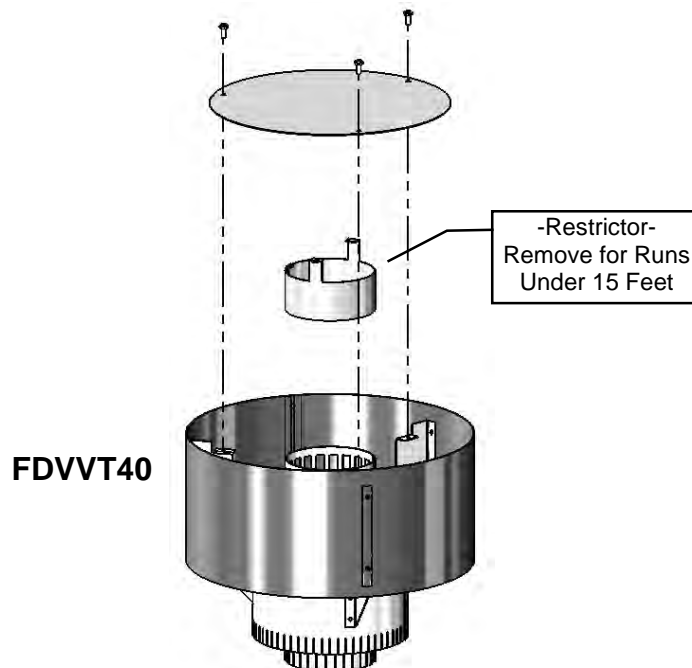

# FDV451 / MQFDV453 Vertical Vent Installation

## FDVSK: Vertical Vent Starter Kit

Starter Kit contains: Attic Insulation Shield, Decorative Ceiling Trim Ring, Black Band, brass Band, Roof Support, Spacer Springs (6), Mill Pac.

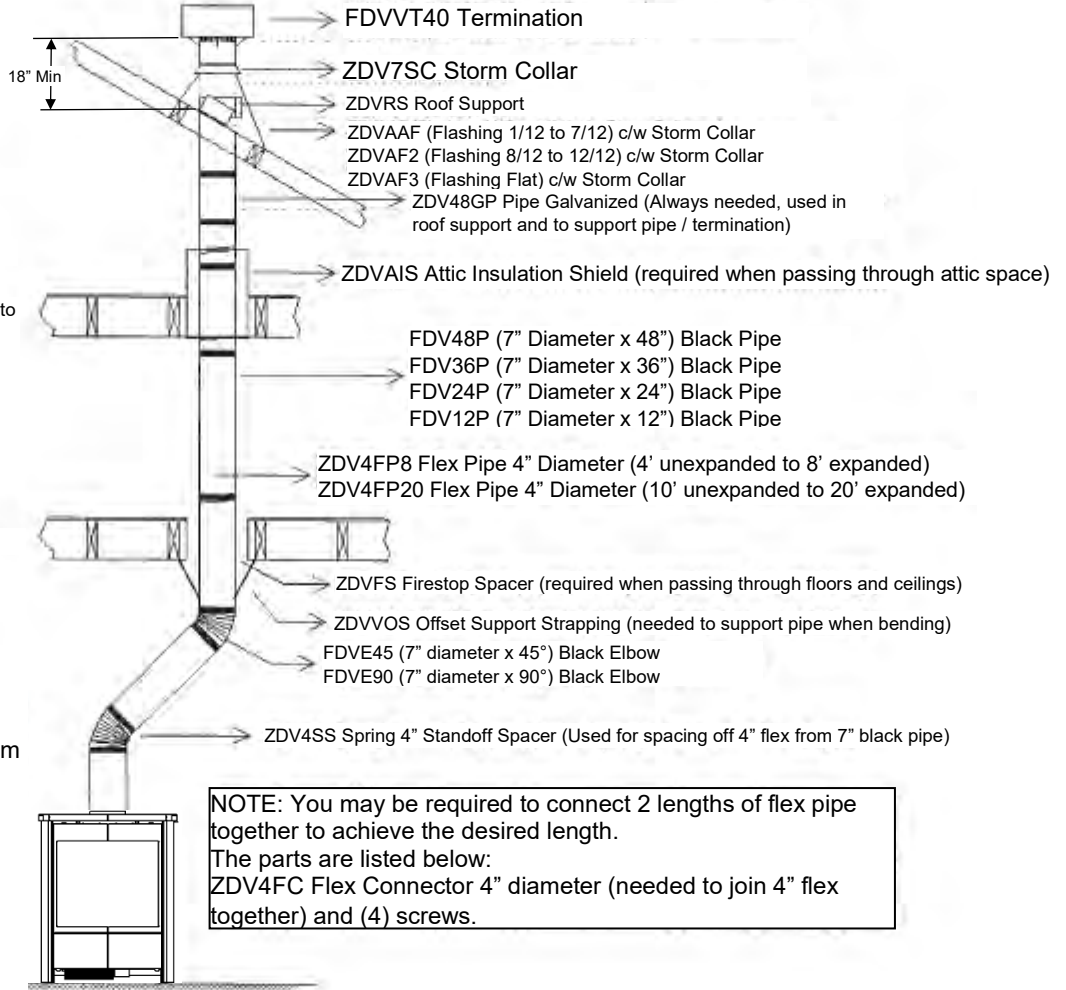
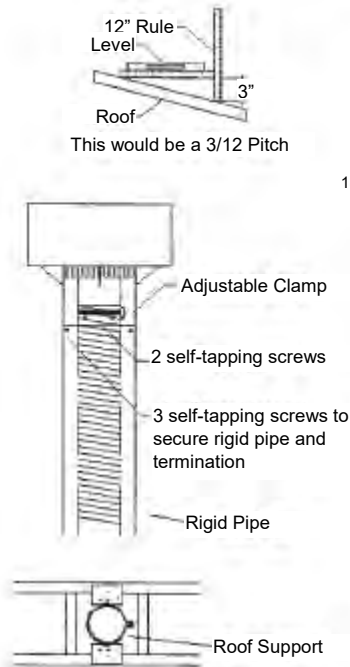

An Attic Insulation Shield must be installed where the vent passes from a lower living space into an attic space where the chimney is not enclosed. It is designed to keep insulation materials away from the chimney.

When installing the Attic Insulation Shield where the chimney passes from a living space to an attic space, install the shield from below and nail in place using 1" spiral nails.

A firestop must be installed on the bottom side of the joists when passing through a ceiling or floor. If an attic insulation shield is to be used, a firestop is not required.

One pair (two) 45° elbows may be used to provide an offset in order to avoid cutting of joists and to clear other obstructions.

When using 45° elbows, an elbow support is required directly above the highest elbow.

When installing a bend in a joist area a minimum of 2" clearance to combustibles to the top of bend must be maintained, sides and bottom of pipe, a 1" clearance to combustibles must be maintained. If running horizontally through an area, a 1" clearance to the top of the horizontal pipe must be maintained.

Maximum vertical height of system should not exceed 45 feet.

Spacer springs to be installed on 4" flex pipe every 3 ft. on vertical runs. On 45° elbows or 90° elbows a spacer spring is needed on the start of the bend and on the end of bend.

**NOTE:** You may be required to connect 2 lengths of flex pipe together to achieve the desired length. The parts are listed below: ZDV4FC Flex Connector 4" diameter (needed to join 4" flex together) and (4) screws.

## Vertical Venting in Cold Climates

In cold climate conditions where temperatures go below -10°C [14°F], we recommend that the chase be insulated and where the vent pipe enters into the attic space that the pipe be wrapped with an insulated Mylar sleeve. This will increase the temperature of the vent and help the appliance to vent properly in cold weather conditions.

It is also important in vertical vented direct vent appliances that the appliance be operated daily during the winter months as this will help stop the Termination from freezing up. We recommend using a thermostat set at room temperature to allow the unit to cycle.

For IPI models it may be necessary to set the appliance to Standing Pilot mode to maintain heat in the cavity. The purpose of this procedure is to prevent cold air from penetrating the chimney and then onto the living space. Therefore, when the internal temperature is slightly elevated the fireplace is able to freely exhaust its combustion and hence making it easier to startup.

## Troubleshooting the Gas Control System



### WARNING

BEFORE DOING ANY GAS CONTROL SERVICE WORK, REMOVE THE GLASS FRONT. Before troubleshooting the gas control system, be sure external gas shut off is in the "On" position.

| Problem   | Possible Causes   | Corrective Action  |
|---|---|--|
| Spark igniter will not light.   | <p>Defective or misaligned electrode at pilot.</p> <p>Defective igniter (push-button).</p>  | <p>Check for spark at electrode and pilot: if no spark and electrode wire is properly connected, replace igniter.</p> <p>Using a match, light pilot. If pilot lights, turn off pilot and push the red button again. If pilot will not light - check gap at electrode and pilot should be 1/8" to 1/4" to have a strong spark.</p>  |
| Pilot will not stay lit after carefully following lighting instructions.    | <p>Defective thermocouple (flame switch where applicable).</p> <p>Defective valve magnet.</p>   | <p>Check pilot flame. Must impinge on generator and thermocouple. Clean and/or adjust pilot for maximum flame impingement on generator and thermocouple. Replace thermocouple if pilot will not hold. (Hand tight 1/8 turn on replacement)</p> <p>Replace valve, if pilot won't hold after the thermocouple is replaced.</p>   |
| Pilot burning, no gas to burner, valve knob "ON", and wall switch "ON".     | <p>Wall switch or wires defective.</p> <p>Generator may not be generating sufficient voltage.</p> <p>Plugged burner orifice.</p> <p>Defective automatic valve operator.</p> | <p>Check wall switch and wires for proper connections. Jumper wire across terminals at wall switch. If burner comes on, replace defective wall switch. If okay, jumper wires, across wall switch wires at valve. If burner comes on, wires are faulty or connections are bad.</p> <p>Check generator with millivolt meter. Take reading at generator terminals of gas valve. Should read 325 millivolts minimum while holding valve knob depressed in pilot position and wall switch "off" Replace faulty generator if reading is below specified minimum.</p> <p>Check burner orifice for stoppage and remove.</p> <p>Remove wall switch wires from gas valve. Install jumper wires from top bottom terminals of gas valve. Turn valve on "ON". If main burner does not light, replace valve.</p> |
| Frequent pilot outage problem.  | Pilot flame may be too low or blowing (high) causing the pilot safety to drop out.  | Clean and/or adjust pilot flame for maximum flame impingement on generator and thermocouple.   |
| Flame lifts off burner and goes out in less than 30 seconds.                | The inner liner has come off flue or termination, flame is starving for oxygen.   | Attach the inner liner to flue or termination using screws, silicone and clamps as stated in manual.   |
| Flame lifts off burner on one side while the rest of the flame remains lit. | Improper installation of firebrick. Firebrick is likely leaning.  | Be sure to position firebrick against firebox walls and be sure to use brick clips attached to the inner side of firebox.  |

**-FDV451 KINGSMAN STOVE-**

**VANTAGE FREE STANDING DIRECT VENT GAS STOVE**

Listed for USA/Canada as a Vented Gas Fireplace Heater, Dual Burner, Ceramic Glass, Glowing Embers, Hi/Lo SIT Valve, On/Off Switch, 4/7" Flue 34,500 BTU NG, 31,000 BTU Propane

**Fireplace Part Numbers**

|           |   |
|-----------|---|
| FDV451N   | Free Standing Direct Vent Stove - Natural Gas |
| FDV451NE  | Free Standing Direct Vent Stove - Natural Gas |
| FDV451LP  | Free Standing Direct Vent Stove - Propane     |
| FDV451LPE | Free Standing Direct Vent Stove - Propane     |

**DOOR FRONTS: (REQUIRED FOR EACH UNIT)**

|         |  |
|---------|--|
| F450FBL | Charcoal Door Face and Vent Lid, Flat Black Posts, Safety Screen   |
| F450FPB | Charcoal Door Face, Powder Black Vent Lid and Posts, Safety Screen |
| F450FSS | Charcoal Door Face and Vent Lid, Stainless Posts, Safety Screen    |

**SIDE DOORS: (REQUIRED FOR EACH UNIT)**

|           |  |
|-----------|--|
| F451SDSBL | Side Doors - Black Frame, Charcoal Solid Panel           |
| F451SDSPB | Side Doors - Powder Black Frame, Charcoal Solid Panel    |
| F451SDSSS | Side Doors - Stainless Steel Frame, Charcoal Solid Panel |
| F451SDFBL | Side Doors - Black Frame, Charcoal Flame Panel           |
| F451SDFPB | Side Doors - Powder Black Frame, Charcoal Flame Panel    |
| F451SDFSS | Side Doors - Stainless Steel Frame, Charcoal Flame Panel |

**LOG SET: (REQUIRED FOR EACH UNIT)**

|         |                                     |
|---------|-------------------------------------|
| LOGF451 | Log Set - Five Piece Cast Split Oak |
|---------|-------------------------------------|

**Accessories**

|        |  |
|--------|--|
| F45LG  | Log Grate  |
| F450FK | Fan Kit w/Variable Speed Control (Temperature Sensing) |
| F451RL | Refractory Liner - 1 Back Liner, 2 Side Liners         |
| F451PL | Porcelain Liner - 1 Back Liner, 2 Side Liners          |

|          |  |
|----------|--|
| Z1MT     | Thermostat Millivolt Wall Mount                                |
| Z80PT    | Thermostat Programmable Digital Millivolt Wall Mount (1F80-40) |
| GFRC     | Remote Control Millivolt / IPI - On/Off                        |
| GTRC     | Remote Control Millivolt - Thermostat                          |
| GTMR CN  | Remote Control Millivolt - Thermostat/Modulating - NG          |
| GTMR CP  | Remote Control Millivolt - Thermostat/Modulating - LP          |
| GTFR CN  | Remote Control Millivolt - Thermostat/Modulating/Fan - NG      |
| GTFR CP  | Remote Control Millivolt - Thermostat/Modulating/Fan - LP      |
| EGTRC    | Remote Control IPI (Thermostat)                                |
| EGTMR CN | Remote Control IPI (Thermostat/Modulating - NG)                |
| EGTMR CP | Remote Control IPI   |

|          |   |
|----------|---|
|          | (Thermostat/Modulating - LP)                        |
| EGTFR CN | Remote Control IPI (Thermostat/Modulating/Fan - NG) |
| EGTFR CP | Remote Control IPI (Thermostat/Modulating/Fan - LP) |
| FV7FBT   | Decorative Brass Collar 7"                          |
| F7DBC    | Decorative Black Collar 7"                          |
| F7DTP    | Decorative Black Wall Trim Plate                    |



---

**-MQFDV453 MARQUIS STOVE-**

---

**VANTAGE FREE STANDING DIRECT VENT GAS STOVE – BAY VIEW**

---

Listed for USA/Canada as a Vented Gas Fireplace Heater, Dual Burner, Ceramic Glass, Glowing Embers, Hi/Lo SIT Valve, On/Off Switch, 4/7" Flue 34,500 BTU NG, 31,000 BTU Propane

|             |  |
|-------------|--|
| MQFDV453N   | Free Standing Stove - (as above) Millivolt - Natural Gas - Black   |
| MQFDV453LP  | Free Standing Stove - (as above) Millivolt - Propane - Black       |
| MQFDV453NE  | Free Standing Stove - Pedestal (as above) IPI -Natural Gas - Black |
| MQFDV453LPE | Free Standing Stove - Pedestal (as above) IPI -Propane - Black     |

---

**DOOR FRONTS: (REQUIRED FOR EACH UNIT)**

---

|         |  |
|---------|--|
| F450FBL | Charcoal Door Face and Vent Lid, Flat Black Posts, Safety Screen   |
| F450FPB | Charcoal Door Face, Powder Black Vent Lid and Posts, Safety Screen |
| F450FSS | Charcoal Door Face and Vent Lid, Stainless Posts, Safety Screen    |

---

**SIDE DOORS: (REQUIRED FOR EACH UNIT)**

---

|           |  |
|-----------|--|
| MQ453SDBL | Side Doors - Black Frame, Charcoal Solid Panel, Safety Screens           |
| MQ453SDPB | Side Doors - Powder Black Frame, Charcoal Solid Panel, Safety Screens    |
| MQ453SDSS | Side Doors - Stainless Steel Frame, Charcoal Solid Panel, Safety Screens |

---

**LOG SET OR MEDIA: (REQUIRED FOR EACH UNIT)**

---

|           |  |
|-----------|--|
| LOGF451   | Log Set - Oak                            |
| MQLOGF452 | Log Set - Oak                            |
| MQLOGF453 | Log Set - Driftwood                      |
| MQSTONE   | Decorative Stones                        |
| MQROCK2   | Rock Set Natural                         |
| MQROCK3   | Rock Set Multi-Color                     |
| MQEMBER   | Glowing Embers                           |
| MQG5W     | Decorative Glass 1/2" White 5LB          |
| MQG5A     | Decorative Ember Glass Cobalt Blue 5LB   |
| MQG5B     | Decorative Ember Glass – Black 5LB       |
| MQG5ZG    | Decorative Glass- Zircon Glacier Ice 5LB |
| MQG5C     | Glass Media - 1/2" Bronze - 5 lbs        |
| RBCB1     | Cannonballs - Assorted size and colors   |

---

**Accessories**

---

|        |  |
|--------|--|
| F45LG  | Log Grate  |
| F450FK | Fan Kit w/Variable Speed Control (Temperature Sensing)         |
| F453RL | Refractory Liner – Back Liner Only                             |
| F453PL | Porcelain Liner – Back Liner Only                              |
| Z1MT   | Thermostat Millivolt Wall Mount                                |
| Z80PT  | Thermostat Programmable Digital Millivolt Wall Mount (1F80-40) |
| GFRC   | Remote Control Millivolt / IPI – On/Off                        |
| GTRC   | Remote Control Millivolt - Thermostat                          |
| GTMRCN | Remote Control Millivolt – Thermostat/Modulating - NG          |
| GTMRCP | Remote Control Millivolt – Thermostat/Modulating - LP          |
| GTFRCN | Remote Control Millivolt – Thermostat/Modulating/Fan - NG      |

---

|         |   |
|---------|---|
| GTFRCP  | Remote Control Millivolt – Thermostat/Modulating/Fan – LP |
| EGTRC   | Remote Control IPI (Thermostat)                           |
| EGTMRCN | Remote Control IPI (Thermostat/Modulating - NG)           |
| EGTMRCP | Remote Control IPI (Thermostat/Modulating - LP)           |
| EGTFRCN | Remote Control IPI (Thermostat/Modulating/Fan - NG)       |
| EGTFRCP | Remote Control IPI (Thermostat/Modulating/Fan - LP)       |
| FV7FBT  | Decorative Brass Collar 7"                                |
| F7DBC   | Decorative Black Collar 7"                                |
| F7DTP   | Decorative Black Wall Trim Plate                          |

---

---

**COMMON PARTS**

---

**Valve System Parts / Millivolt**

|             |                                  |
|-------------|----------------------------------|
| 1000-P136WR | Generator / Thermopile           |
| 1001-P069SI | Electrode Sparker 915.069 TC SIT |
| 1001-P216SI | Thermocouple 290.216 TC SIT      |
| 1001-P165SI | Orifice Pilot NG 977.165 TC SIT  |
| 1001-P167SI | Orifice Pilot LP 977.167 TC SIT  |
| 1001-P280SI | Tubing 24"                       |
| 1001-P633SI | Valve Nova LP Hi/Lo 0820651      |
| 1001-P634SI | Valve Nova NG Hi/Lo 0820652      |
| 1001-P713SI | Pilot Burner LP 199.713 TC SIT   |
| 1001-P714SI | Pilot Burner NG 199.714 TC SIT   |

**Electronic Ignition Replacement Parts IPI**

|             |                              |
|-------------|------------------------------|
| 1006-P002si | Valve IPI (NG; Hi/Lo)        |
| 1006-P003si | Valve IPI (LP; Hi/Lo)        |
| 1002-P047si | Pilot Assembly (LP)          |
| 1002-P033si | Pilot Assembly (NG)          |
| 1002-P017si | Spark Electrode (24")        |
| 1002-P903si | Electrode Flame Sensor (24") |
| 1002-P302si | IPI Ignition Board           |
| 1002-P850si | AC Wall Adapter              |
| 1002-P12BH  | Battery Pack                 |
| 1002-P912si | Wiring Harness               |
| 1001-P166si | Orifice Pilot (NG)           |
| 1001-P168si | Orifice Pilot (LP)           |
| 1002-P013si | Stepper Motor (NG)           |
| 1002-P012si | Stepper Motor (LP)           |
| 1002-P016si | Hi/Lo Regulator (NG)         |
| 1002-P014si | Hi/Lo Regulator (LP)         |
| 6961-P161   | 16" Extension Cord           |

**Conversion Kit**

|             |   |
|-------------|---|
| 450DV-CKLP  | Conversion Kit - Millivolt - To Propane     |
| 450DV-CKNG  | Conversion Kit - Millivolt - To Natural Gas |
| 450DV-CKLPI | Conversion Kit - IPI - To Propane           |
| 450DV-CKNGI | Conversion Kit - IPI - To Natural Gas       |

**Miscellaneous Parts**

|            |  |
|------------|--|
| 1000-150GE | Silicone GE Red IS806 #736                 |
| 1000-150MP | Hi-Temp Millpac Sealant 840099             |
| 1000-214   | Piezo-Igniter 1244-17 MARK 21              |
| 1000-215   | Pal Nut (18MMX1.5MM)BLK (1364.03)          |
| 1000-218   | Switch Ivory (1451/001)                    |
| 1000-227   | Cover Ivory (86001/001)                    |
| 1000-255   | Orifice Brass - (State Size)               |
| 3600-B139  | Explosion felt Gasket                      |
| 2000-080   | Thermodisc 2450 (For Blower)               |
| 1000-306   | Thermalcord - Adhesive Back for Door Frame |
| 1000-085   | Control Variable Speed KBWC-13BV           |
| FP15GC     | Stainless Steel Gas Connector              |
| 450FDV-300 | Front Glass                                |
| 453FDV-309 | Side Glass                                 |

---

**KINGSMAN FIREPLACE VENTING**

---

|        |   |
|--------|---|
| FDVHSK | <b>Horizontal Vent Starter Kit - (Direct Vent Stoves)</b> Starter Kit Contains:<br>Horizontal Vent Termination, Zero Clearance Wall Sleeve, Black Wall Trim Ring, 7" Dia. Black Pipe 24" Length, 7" Dia. Black Pipe 48" Length 7" - 90 Degree Black Elbow, 4" Flex 48" Unexpanded (96" Expanded) 7" Black Bands(3), Mill Pac. |
|--------|---|

|          |   |
|----------|---|
| FDVVSK   | <b>Vertical Vent Starter Kit - (Direct Vent Stoves)</b> Starter Kit Contains:<br>Attic Insulation Shield, Fire Stop, Ceiling Trim Plate, Black Trim Ring (2), Roof Support, Spacer Springs(6), Mill Pac |
| Z47VT    | Vertical Vent Termination   |
| FDVVT40  | Vertical Vent Termination Converts from 15' - 40' to 15' and under  |
| FDVHT    | Horizontal Vent Termination   |
| FDVHSCU  | Safety Cage for Horizontal Termination  |
| FDVHSQ   | Horizontal Square Termination   |
| Z47ST24  | Horizontal Snorkel Termination (24" Tall, 14-1/2" Center to Center)   |
| Z47ST36  | Horizontal Snorkel Termination (36" Tall, 26-1/2" Center to Center)   |
| Z57STSC  | Safety Cage for Horizontal Snorkel Termination  |
| FDV48P   | Black Pipe (7" Diameter x 48")  |
| FDV36P   | Black Pipe (7" Diameter x 36")  |
| FDV24P   | Black Pipe (7" Diameter x 24")  |
| FDV12P   | Black Pipe (7" Diameter x 12")  |
| FDVE90   | Black Elbow (7" Diameter x 90 Degree)   |
| FDVE45   | Black Elbow (7" Diameter x 45 Degree)   |
| ZDVDKA   | Dura-Vent Stove Adapter ( for Direct Vent Stoves)   |
| ZDV AIS  | Attic Insulation Shield   |
| ZDVVOS   | Offset Support  |
| ZDVFS    | Firestop Spacer   |
| ZDVRS    | Roof Support  |
| ZDVSS    | Siding Shield   |
| ZDVWT    | Wall Thimble (Horizontal Venting)   |
| ZDV48GP  | Galvanized Pipe 7" Dia. x 48" (Vertical Installations)  |
| ZDV4FP8  | Flex Pipe 4" Diameter (4' Unexpanded to 8' Expanded)  |
| ZDV4FP20 | Flex Pipe 4" Diameter (10' Unexpanded to 20' Expanded)  |
| ZDV4FC   | Flex Connector 4" Diameter  |
| ZDV4SS   | Spring 4" Standoff Spacer   |
| ZDVAAF   | Flashing 7" c/w Storm Collar (1/12 to 7/12)   |
| ZDVAF2   | Flashing 7" c/w Storm Collar (8/12 to 12/12)  |
| ZDVAF3   | Flashing 7" c/w Storm Collar Flat   |
| ZDV7SC   | Storm Collar 7 Inch   |



## LIMITED LIFETIME WARRANTY

This Limited Lifetime Warranty applies only while the unit remains at the site of the original installation and only if the unit is installed inside the continental United States, Alaska, Hawaii, and Canada. The warranty applies only if the unit is installed and operated in accordance with the printed instructions and in compliance with applicable installation and building codes and good trade practices.

### BASIC ONE YEAR WARRANTY

During the first year after installation, we will provide a replacement for any component part of your unit found to be defective in materials or workmanship, including labour costs. Repair work requires prior approval by Kingsman, labour costs are based on a predetermined rate schedule and any repair work must be done through an authorized Kingsman dealer.

(Excluded Components: Accent Light Bulbs, Gasketing and Paint)

### LIMITED LIFETIME WARRANTY

The heat exchanger, combustion chamber and burner of every Kingsman product excluding the Outdoor Firepit are warranted against materials or workmanship during the period the product is owned by the original owner. The part to be replaced must be returned to our distributor in exchange for the replacement part. Any labor, material, freight and/or handling charges associated with any repair or replacement pursuant to this Limited Lifetime Warranty will not be covered by this warranty.

### GENERAL TERMS

In lieu of providing a replacement part, we may, at our option, provide the distributor's component purchase price from us or a credit equal to the distributor's component purchase price from us toward the purchase of any new unit which we distribute. If a credit is given in lieu of a replacement part, the rating plate from the unit being replaced must be submitted on a warranty claim, and the unit being replaced must be made available to our distributor for disposition.

In establishing the date of installation for any purpose, including determination of the starting date for the term of this Limited Lifetime Warranty, reasonable proof of the original installation date must be presented\*, otherwise the effective date will be based upon the date of manufacture plus thirty (30) days.

We will not be responsible for and you, the user, will pay for: (a) damages caused by accident, abuse, negligence, misuse, riot, fire, flood, or Acts of God (b) damages caused by operating the unit where there is a corrosive atmosphere containing chlorine, fluorine, or any other damaging chemicals (other than in a normal residential environment) (c) damages caused by any unauthorized alteration or repair of the unit affecting its stability or performance (d) damages caused by improper matching or application of the unit or the unit's components (e) damages caused by failing to provide proper maintenance and service to the unit (f) any expenses incurred for erecting, disconnecting or dismantling the unit (g) parts or supplies used in connection with service or maintenance (h) damage repairs, inoperation or inefficiency resulting from faulty installation or application (i) electricity or fuel costs or any increase in electricity or fuel cost whatsoever including additional or unusual use of supplemental electric heat.

We shall not be liable for any incidental, consequential, or special damages or expenses in connection with any use or failure of this unit. We have not made and do not make any representation or warranty of fitness for a particular use or purpose, and there is no implied condition of fitness for a particular use or purpose. We make no express warranties except as stated in this Limited Lifetime Warranty. No one is authorized to change this Limited Lifetime Warranty or to create for us any other obligation or liability in connections with this unit. Any implied warranties shall last for one year after the original installation. Some states and provinces do not allow the exclusion or limitation of incidental or consequential damages or do not allow limitations on how long an implied warranty or condition lasts, so the above limitations or exclusions may not apply to you. The provisions of this limited warranty are in additions to and not a modification of or subtraction from any statutory warranties and other rights and remedies provided by law.

Save this certificate. It gives you specific legal rights, and you may also have other rights which may vary from state to state and province to province.

In the event your unit needs servicing, contact your dealer or contractor who installed or serviced your unit. When requesting service, please have the model and serial number from each unit readily available. If your dealer needs assistance, the distributor is available for support and we, in turn support the distributor's efforts.

Fill in the installation date and model and serial numbers of the unit in the space provided below and retain this limited warranty for your files.

Model No. \_\_\_\_\_ Serial No. \_\_\_\_\_ Date installed \_\_\_\_\_

Dealer or Contractor Name: \_\_\_\_\_

\*To receive advantage of your warranty, you must retain the original records that can establish the installation date of your unit.

**The Ultimate in Design, Engineering & Quality**