



# Submittal Form: 1PAMSHH24-20.5

24,000 BTU Hyper Heat System

HYPER-HEAT

MINI SPLIT SUBMITTAL SHEET

Project Name:	
Location:	
Engineer:	
Submitted To:	
Submitted By:	
Reference:	

Approval:	
Date:	
Construction:	
Unit #:	
Drawing #:	

MODEL #	
INDOOR:	1PAMSHH24-SZW-20.5
OUTDOOR:	1PAMSHH24-SZO-20.5



### ELECTRICAL

Power Supply	Ph-V-Hz	208-230V~ 60Hz, 1Ph
Minimum Circuit Ampacity	A	20
Maximum Fuse Size	A	30

### COOLING

Capacity:Rated(Min-Max)	Btu/h	24000(5500-24500)
Input	W	1920
Rated Current	A	8.4
EER	Btu/w	13.0
SEER	Btu/w	20.5

### HEATING

Capacity:Rated(Min-Max)	Btu/h	24000(6000-32000)
Input	W	2500
Rated Current	A	10.9
COP	A	2.81
HSPF4 / HSPF5	W/W	11.50 / 9.60
Low Temperature Heating Capacity (5° F)	Btu/h	24000

### COMPRESSOR

Model		ATF235D22UMT
Type		ROTARY
Brand		GMCC
Capacity	Btu/h	24345
Input	W	1970
Rated Current (RLA)	A	14
Refrigerant Oil/Charge	ml	POE(VG74)/670

### SYSTEM DATA

Design Pressure	PSIG	550/340PSIG
Refrigerant	oz	R410A/91.7
Refrigerant Precharge	ft	25
Additional Charge Per ft.	oz	0.322
Liquid	in	Ø3/8"
Gas	in	Ø5/8"
Max. Refrigerant Pipe Length	ft.	164
Max Difference In Level	ft.	82

### INDOOR UNIT DATA

Model		ZKFP-60-8-1
Brand		Welling
Input	W	72
RLA	A	0.3
Speed(H/M/L)	r/min	1200/1100/900
Indoor Air Flow (H/M/L)	CFM	794/647/500
Indoor Noise Level (H/M/L)	dB(A)	47.5/44/36.5

### INDOOR UNIT DIMENSIONS

Dimension(WxDxH)	inch	46.69x10.16x13.39
Packaging(WxDxH)	inch	49.80x13.39x16.53
Net/Gross Weight	lbs.	40.12/50.26

### OUTDOOR UNIT DATA

Model		ZKFN-120-8-2
Brand		Welling
Input	W	150
RLA	A	0.5
Speed(H/M/L)	r/min	850/750/600
Outdoor Air Flow	CFM	2355
Outdoor Noise Level	dB(A)	60.0

### OUTDOOR UNIT DIMENSIONS

Dimension(WxDxH)	inch	37.24/16.14/31.89
Packaging(WxDxH)	inch	42.91x19.69x34.45
Net/Gross Weight	lbs.	135.58/148.81

### OPERATION TEMPERATURE

Indoor(Cooling/Heating)	Deg. F	62~90/32~86
Outdoor(Cooling/Heating)	Deg. F	-22~122/-22~86



**SUBMITTAL DATA:** 1PAMSHH24-20.5  
**Outdoor Model Number:** 1PAMSHH24-SZO-20.5

24,000 BTU Hyper Heat System

**24,000 BTU**

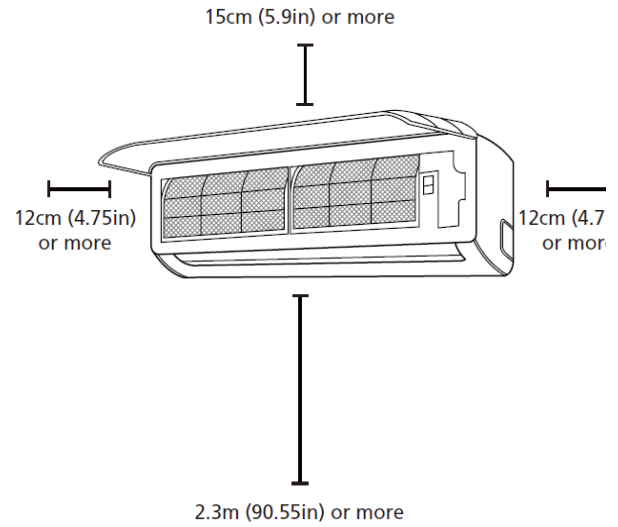
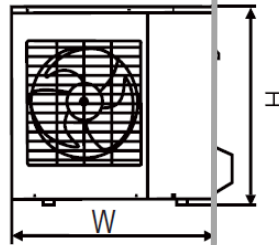
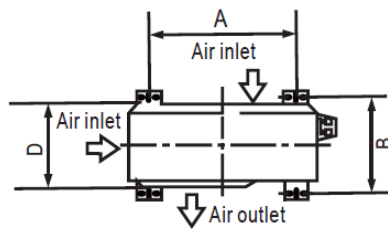
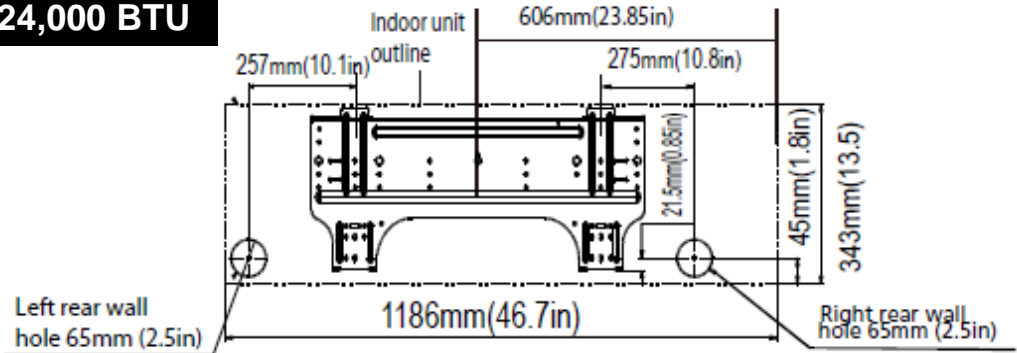

Outdoor Unit Dimensions(WxHxD)	Mounting Dimensions	
	A	B
inches	in.	in.
26.8x17x11.2	18.1	11.49
27.5x21.6x10.62	17.7	10.24
30.7x21.25x9.85	21.6	10.85
33.25x27.5x12.6	22	13.2
31.9x22x12.2	21.6	12.8
27.5x21.6x10.82	17.7	10.24
30.3x21.85x11.81	19.2	11.73
31.5x21.8x13.1	20.24	13.39
33.25x27.63x14.29	21.26	13.8
35.4x33.85x12.4	23.2	13.1
37.2x31.9x15.55	25.2	15.95
37.21x31.9x16.53	26.5	15.87
37.21x31.9x16.14	26.5	15.87

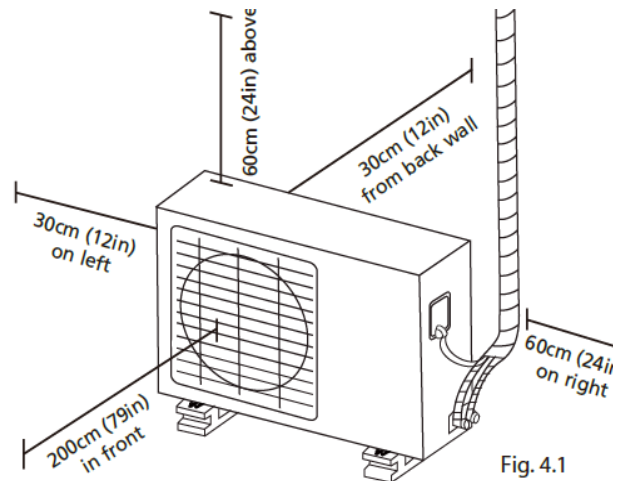

Fig. 4.1