

**Submittal Form: 1PAMSHH18-22.5***18,000 BTU Hyper Heat System***HYPER-HEAT
MINI SPLIT SUBMITTAL SHEET**

Project Name:	
Location:	
Engineer:	
Submitted To:	
Submitted By:	
Reference:	

Approval:	
Date:	
Construction:	
Unit #:	
Drawing #:	

MODEL #	
INDOOR:	1PAMSHH18-SZW-22.5
OUTDOOR:	1PAMSHH18-SZO-22.5

**ELECTRICAL**

Power Supply	Ph-V-Hz	208/230V,1Ph,60Hz
Minimum Circuit Ampacity	A	18
Maximum Fuse Size	A	25

COOLING

Capacity:Rated(Min-Max)	Btu/h	16000(4500-17800)
Input	W	1230
Rated Current	A	5.35
EER	Btu/w	13.0
SEER	Btu/w	22.5

HEATING

Capacity:Rated(Min-Max)	Btu/h	17000(5500-23000)
Input	W	1383
Rated Current	A	6.02
COP	A	3.60
HSPF4 / HSPF5	W/W	11.00 / 9.00
Low Temperature Heating Capacity (5° F)	Btu/h	18000

COMPRESSOR

Model		ATM150D23UFZ
Type		ROTARY
Brand		GMCC
Capacity	Btu/h	15388
Input	W	1170
Rated Current (RLA)	A	8.1
Refrigerant Oil/Charge	ml	ESTEL OIL VG74/500

SYSTEM DATA

Design Pressure	PSIG	550/340PSIG
Refrigerant	oz	R410A/60.0
Refrigerant Precharge	ft	25
Additional Charge Per ft.	oz	0.161
Liquid	in	Φ1/4"
Gas	in	Φ1/2"
Max. Refrigerant Pipe Length	ft.	98
Max Difference In Level	ft.	66

INDOOR UNIT DATA

Model		ZKFP-58-8-1
Brand		Welling
Input	W	150
RLA	A	0.3
Speed(H/M/L)	r/min	1100/900/700
Indoor Air Flow (H/M/L)	CFM	365/271/156
Indoor Noise Level (H/M/L)	dB(A)	45/39.5/29.5

INDOOR UNIT DIMENSIONS

Dimension(WxDxH)	inch	38.98x8.58x12.40
Packaging(WxDxH)	inch	41.93x11.81x15.75
Net/Gross Weight	lbs.	27/36

OUTDOOR UNIT DATA

Model		ZKFN-50-8-2
Brand		Welling
Input	W	115/81/44
RLA	A	0.5
Speed(H/M/L)	r/min	850/750/600
Outdoor Air Flow	CFM	1383
Outdoor Noise Level	dB(A)	57.0

OUTDOOR UNIT DIMENSIONS

Dimension(WxDxH)	inch	33x14x28
Packaging(WxDxH)	inch	38x16x30
Net/Gross Weight	lbs.	108/115

OPERATION TEMPERATURE

Indoor(Cooling/Heating)	Deg. F	62~90/32~86
Outdoor(Cooling/Heating)	Deg. F	-22~122/-22~86



SUBMITTAL DATA: 1PAMSHH18-22.5
Indoor Model Number: 1PAMSHH18-SZW-22.5
Outdoor Model Number: 1PAMSHH18-SZO-22.5

18,000 BTU Hyper Heat System

18,000 BTU

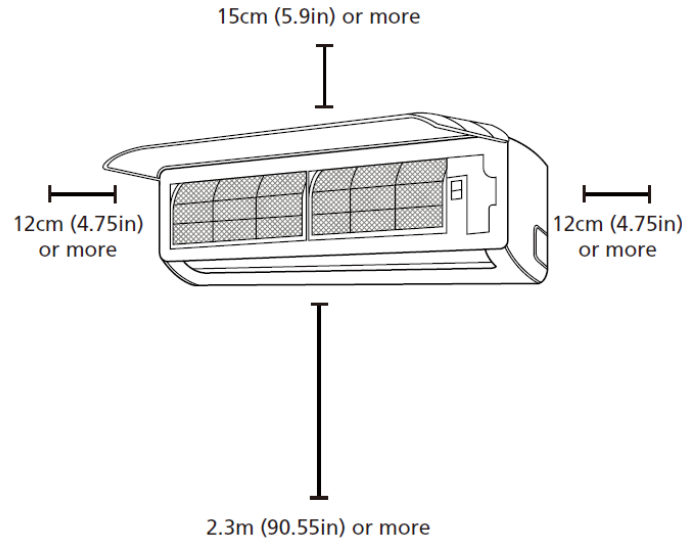
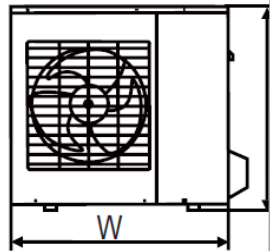
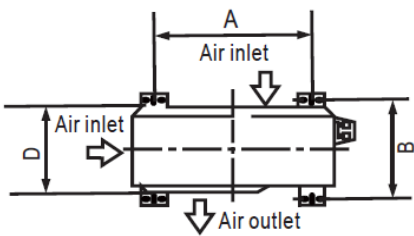
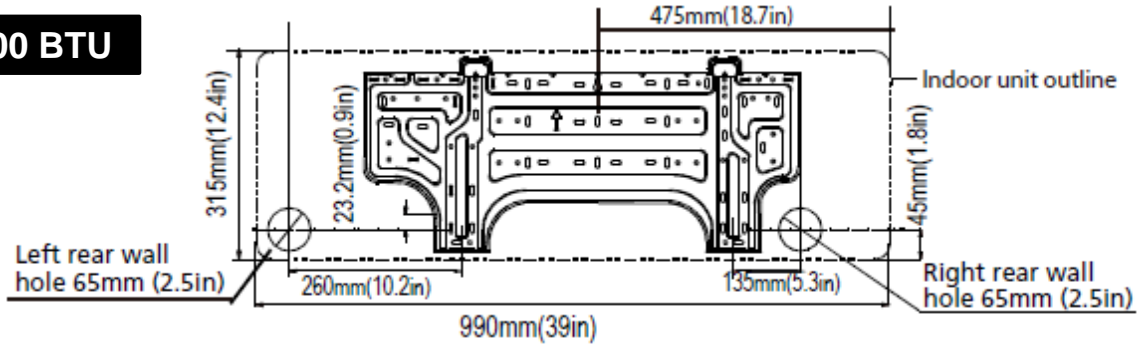

Outdoor Unit Dimensions(WxHxD)	Mounting Dimensions	
	A	B
inches	in.	in.
26.8x17x11.2	18.1	11.49
27.5x21.6x10.62	17.7	10.24
30.7x21.25x9.85	21.6	10.85
33.25x27.5x12.6	22	13.2
31.9x22x12.2	21.6	12.8
27.5x21.6x10.82	17.7	10.24
30.3x21.85x11.81	19.2	11.73
31.5x21.8x13.1	20.24	13.39
33.25x27.63x14.29	21.26	13.8
35.4x33.85x12.4	23.2	13.1
37.2x31.9x15.55	25.2	15.95
37.21x31.9x16.53	26.5	15.87
37.21x31.9x16.14	26.5	15.87

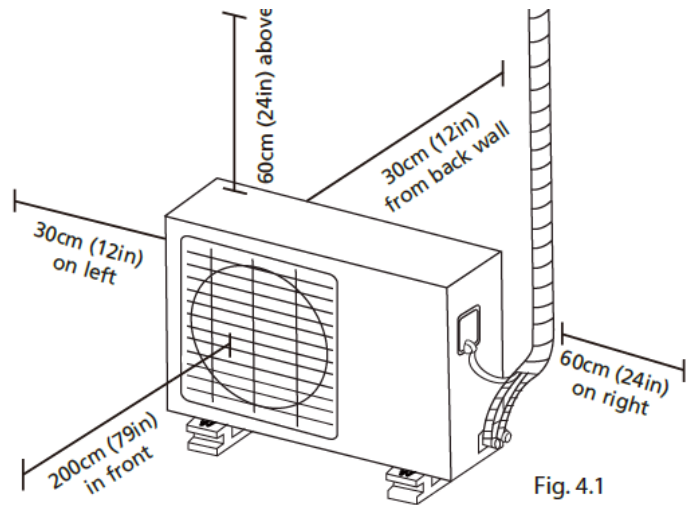

Fig. 4.1